

INSTALLING SEISMIC RESTRAINTS FOR ELECTRICAL EQUIPMENT

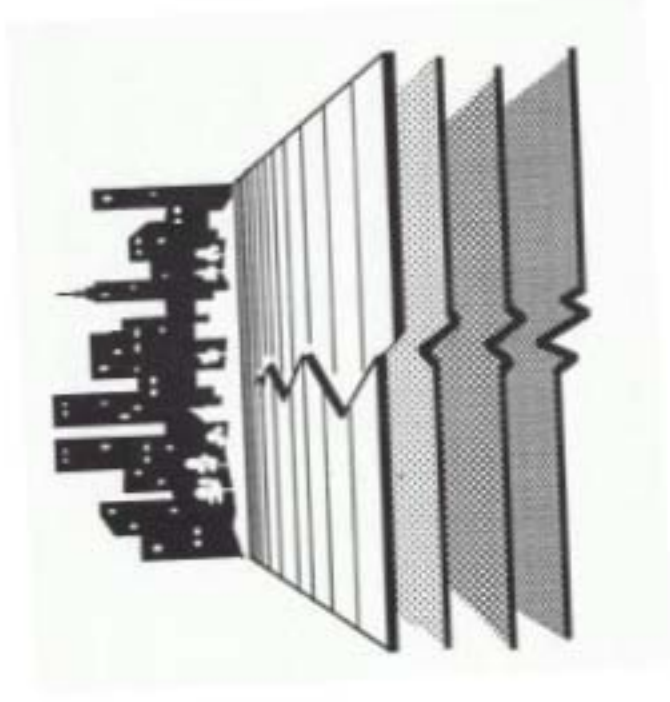

Notice: This guide was prepared by the Vibration Isolation and Seismic Control Manufacturers Association (VISCMA) under a cooperative agreement between the Federal Emergency Management Agency (FEMA) and the American Society of Civil Engineers (ASCE). Any opinions, findings, conclusions, or recommendations expressed in this publication do not necessarily reflect the views of FEMA and ASCE. Additionally, neither FEMA, ASCE, VISCMA, nor any of their employees make any warranty, expressed or implied, nor assumes any legal liability or responsibility for the accuracy, completeness, or usefulness of any information, product, or process included in this publication. Users of information from this publication assume all liability arising from such use.

For additional copies of this guide, call the FEMA Distribution Center: 1-800-480-2520.

For further information concerning this guide or the activities of ASCE, contact the American Society of Civil Engineers, 1801 Alexander Bell Drive, Reston, Virginia, 20191, 703-295-6000.

For further information concerning the activities of the Vibration Isolation and Seismic Control Manufacturers Association, contact Mr. Robert Ecker, 610-971-4850.

All photos used with permission. Photos provided by:

ASCO Power Technologies
 Amber/Booth Company
 American Standard, Inc.
 Caterpillar
 Cooper Lighting
 GARZO, Inc., Equipment & Compressor Accessories
 Hergo Ergonomic Support Systems, Inc.
 IntraPack Corporation
 KINETICS Noise Control
 M.W. Sausse & Co., Inc.
 Mason Industries, Inc.
 Powerware
 Seismic Source Company
 Square D
 Vibration Eliminator Co., Inc.
 Vibration Mountings & Controls, Inc.

INSTALLING SEISMIC RESTRAINTS FOR ELECTRICAL EQUIPMENT

January 2004



FEMA



ASCE

Developed by the Vibration Isolation and Seismic Control Manufacturers Association under a cooperative agreement between the Federal Emergency Management Agency and the American Society of Civil Engineers

ACKNOWLEDGEMENTS

This guide was prepared under Cooperative Agreement EMW-2001-CO-0379 between the Federal Emergency Management Agency and the American Society of Civil Engineers. The contributions of the following are gratefully acknowledged:

Vibration Isolation and Seismic Control Manufacturers Association (VISCMA)

Amber/Booth Company Thybar Corporation
Kinetics Noise Control Vibration Mountings & Controls, Inc.
Mason Industries Vibration Eliminator Co., Inc.
M. W. Sausse & Company

Concrete Anchors Manufacturers Association (CAMA)

The American Society of Civil Engineers (ASCE)

Project Team

Paul Tertell, FEMA Project Officer
Suzanne Ramsey, Project Manager
James Carlson, Principal Investigator
J. Marx Ayres Michael Hagerty
James Borchers James Henderson
Mike Callanan Jerry Lilly
Robert H. Ecker Bill Staehlin

Consulting Advisors - Representatives of

Amber/Booth Company Thybar Corporation
IAPMO Vibration Mountings & Controls, Inc.
Kinetics Noise Control Vibration Eliminator Co., Inc.
Mason Industries, Inc. Wej-it Fastening Systems
M. W. Sausse & Co., Inc.

Advisory Group

George Barna, Omaha Nebraska
Phillip J. Caldwell, Square D Company
Dave Cartier, Electrical Training Trust
Norm Cohen, Los Angeles California
Professor William Elarton, Los Angeles Trade Technical College
Brooke Stauffer, National Electrical Contractors Association

Editing and Layout

Gary Clemmons, GC Ink
Leslie McCasker, McCasker Consulting

Illustrations

Scott Hiner, Creative Marketing Resources

The Federal Emergency Management Agency (FEMA)

TABLE OF CONTENTS

INTRODUCTION 1

EQUIPMENT 4

Automatic Transfer Switches	4
Control Panels	6
Generators	8
Lighting	10
Load Centers and Panelboards	12
Low Voltage: Substations, Capacitor Banks, Switchboards, and Switchgears	14
Medium to High Voltage: Switchgears, Circuit Interrupters, Substation Circuit Breakers, and Walk-in Enclosures	16
Meters and Disconnects	18
Motor Control Centers and Variable Frequency Drives	20
Multi-media Racks	22
Transformers	24
Uninterruptable Power Supplies and Battery Racks	26
Unit Heaters and Tanks	28

RACEWAYS/CONDUITS/CABLE TRAYS 30

ATTACHMENT TYPES 51

Rigid Floor-mounted/Pad-mounted Attachments	51
Roof-mounted Attachments	65
Suspended Attachments	71
Vibration-isolated/Floor-mounted Attachments	87
Wall-mounted Attachments	98

ANCHORS 104

General Anchors	104
Cast-in-place Anchors	111
Lag Bolts	112
Masonry and Drywall Anchors	114
Power-Actuated Anchors	122
Steel Bolt Connections	123
Welding	128
Anchor Sizes for Equipment Weighing Less Than 400 Pounds	130

SPECIAL CASES	133
Cables	133
Control Panels	139
Housekeeping Pads	144
Lighting	148
ANCHOR SELECTION GUIDE	151
ELECTRICAL DANGER INSTRUCTION CHART	160
GLOSSARY	162
INDEX	171

INTRODUCTION

This guide shows equipment installers how to attach electrical equipment to a building to minimize earthquake damage. Many attachment examples are presented, including anchors and the use of special devices called *seismic restraint devices*.

Seismic restraint devices include vibration isolation systems, cable or strut suspension systems, roof attachment systems, and steel shapes.

An electrical danger instruction chart is provided (page 160) as a basic guideline. Follow all safety requirements as required by code, including those listed below:

- Printed instructions shipped with the equipment.
- Instructions in construction drawings and specifications. Use approved construction documents.
- Code-required, industry-accepted practices.
- Electrical safety guidelines and practices.
- Orders from your supervisor.
- Seismic restraint device submittals.

This guide does not replace any of the above referenced materials.

Please note that this guide does not cover:

- Fire protection sprinkler, smoke and fire stops, or fire detection governed by local codes and the National Fire Protection Association.
- Framing design required to elevate equipment above the floor.

If you have questions about any information in this guide, check with your supervisor.

This guide contains the following sections:

- **Equipment:** Arranged according to different kinds of electrical equipment such as computer racks, control panels, lighting, substations, etc.
- **Raceways/Conduits/Cable Trays:** Covers the different ways to install raceways, conduits, and cable trays.
- **Attachment Types:** Gives instructions on installing equipment in different arrangements known as *attachment types*.
- **Anchors:** Shows many different types of anchors used to connect equipment to a building.
- **Special Cases:** Covers housekeeping pads, and other unique applications.

To use this guide:

1. Use the Table of Contents to find the Equipment section that best represents the equipment you are installing.
2. Using the table (see example below) in the Equipment section, find the:
 - type of equipment you are installing in column 1
 - method of installing the equipment in column 2
 - attachment type in column 3.

column 1	column 2	column 3
Typical Equipment	<i>How is equipment to be installed?</i>	<i>Attachment Type</i>
Any type of unit	Connected to angles mounted to the floor	Rigid with angles <i>Go to page 53</i>

3. Turn to the page referenced in column 3 for the equipment/attachment type you have selected. If you are not sure which attachment type is correct, ask your supervisor.
4. Follow the instructions for the attachment type you have selected. These instructions will refer you to the correct anchor section so you can make the connection to the building structure.

NOTE: All instructions in this guide are arranged in order using numbered steps. Please follow every step in the sequence shown.

Special precautions are marked:



A flag means you should take special care before continuing. Read all the information next to a flag before attaching the equipment.



A warning sign means you can cause serious damage to the building, the device, or the equipment if you do not follow the instructions exactly.



A book means you should refer to the manufacturer's printed instructions before continuing.

Note that a Glossary and an Index are also available to facilitate use of this guide.

EQUIPMENT

Automatic Transfer Switches



Be sure to refer to approved construction documents and specifications, seismic restraint submittals, and manufacturer's instructions.

Step 1: Identify the equipment



Figure 1: Automatic transfer switch (surface wall-mounted).

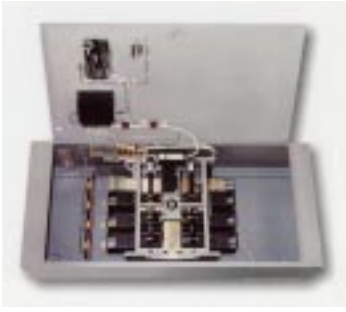

Figure 2: Automatic transfer switch (floor-mounted).



Figure 3: Automatic transfer and bypass-isolation switch (floor-mounted).



Figure 4: Service entrance with transfer switch (floor-mounted).

Step 2: Select the type of attachment

Using the following table, select how the equipment is to be installed, select the attachment type that best matches the installation you have selected, then turn to the page under the attachment type.

Typical Equipment	How is equipment to be installed?	Attachment Type
Any type of unit	Mounted directly to the floor	Rigid Go to page 51
	Connected to angles mounted to the floor	Rigid with angles Go to page 55
	Directly to the wall	Wall-mounted Go to page 98
	Mounted to the wall with angles	Wall-mounted with angles Go to page 100

Table 1: Automatic transfer switch installation types.



Refer to the Electrical Danger Instruction Chart on page 160.

Control Panels



Be sure to refer to approved construction documents and specifications, seismic restraint submittals, and manufacturer's instructions.

Step 1: Identify the equipment



Figure 5: Control panel (flush wall-mounted).



Figure 6: Control panel (surface floor-mounted).



Figure 7: Control panel (floor-mounted).

Step 2: Select the type of attachment

Using the following table, select how the equipment is to be installed, select the attachment type that best matches the installation you have selected, then turn to the page under the attachment type.

Typical Equipment	How is equipment to be installed?	Attachment Type
Any type of unit	Mounted directly to the floor	Rigid Go to page 51
	Connected to angles mounted to the floor	Rigid with angles Go to page 55
	On a raised floor	Raised floor Go to page 61
	Directly to the wall	Wall-mounted Go to page 98
	Mounted to the wall with angles	Wall-mounted with angles Go to page 100
	Strut and Plate framing support systems	Special Cases: Control Panels Go to page 139
	Flush-mounted	Follow manufacturer's instructions
	Connected to companion equipment	Follow manufacturer's instructions

Table 2: Control panel installation types.



Refer to the Electrical Danger Instruction Chart on page 160.

Generators



Be sure to refer to approved construction documents and specifications, seismic restraint submittals, and manufacturer's instructions.

Step 1: Identify the equipment



Figure 8: Generator controls (equipment-mounted).



Figure 9: Housed generator (floor-mounted).



Figure 10: Generator with weatherproof housing (pad-mounted).



Figure 11: Generator with radiator (pad-mounted). Radiator may be remotely mounted.

Step 2: Select the type of attachment

Using the following table, select how the equipment is to be installed, select the attachment type that best matches the installation you have selected, then turn to the page under the attachment type.

Typical Equipment	How is equipment to be installed?	Attachment Type
Any type of generator	Mounted directly to the floor or pad	Rigid Go to page 51
	Connected to angles mounted to the floor	Rigid with angles Go to page 55
	Vibration-isolated	Vibration-isolated/floor-mounted Go to page 87
Generator controls	Roof-mounted or vibration-isolated on a roof	Roof-mounted Go to page 65
	Connected to equipment	Follow manufacturer's instructions

Table 3: Generator installation types.



Refer to the Electrical Danger Instruction Chart on page 160.



For generator fuel tanks, see the Unit Heaters and Tanks equipment section on page 28.



Refer to approved construction documents for installation requirements for exhaust and muffler noise control.

Lighting



Be sure to refer to approved construction documents and specifications, seismic restraint submittals, and manufacturer's instructions.

Step 1: Identify the equipment



Figure 12: Battery powered light.



Figure 13: Exit light/lighted signs.



Figure 14: Flush-mounted light.



Figure 15: Lay-in light.



Figure 16: Pendant light.

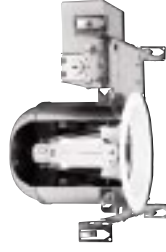

Figure 17: Recessed light.



Figure 18: Wall-mounted light.



Figure 19: Industrial light.

Step 2: Select the type of attachment

Using the following table, select how the equipment is to be installed, select the attachment type that best matches the installation you have selected, then turn to the page under the attachment type.

Typical Equipment	How is equipment to be installed?	Attachment Type
Battery powered light, exit light, or flush-mounted light	Directly attached to any surface using attachment instructions for wall-mounted equipment	Wall-mounted Go to page 98
Lay-in light and flush-mounted light	Installed in T-bar ceilings	Special cases: Lighting Go to page 149
Pendant light	Directly attached to building structure	Special cases: Lighting Go to page 150
Recessed light and industrial light	Directly attached to building structure	Follow manufacturer's instructions
Surface-mounted light	Surface-mounted to horizontal building structure surface. Ceilings must have capacity to transfer load to building structure	Use attachment instructions for wall-mounted equipment Go to page 98
Chandeliers or chain-supported equipment	Suspended from the building structure	Suspended with chain Go to page 86

Table 4: Lighting installation types.



Refer to the Electrical Danger Instruction Chart on page 160.

Load Centers and Panelboards



Be sure to refer to approved construction documents and specifications, seismic restraint submittals, and manufacturer's instructions.

Step 1: Identify the equipment



Figure 20: Load center (flush wall-mounted).



Figure 21: Load center (surface wall-mounted).

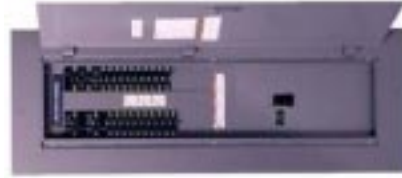

Figure 22: Panelboard (flush wall-mounted).



Figure 23: Panelboard (surface wall-mounted).



Figure 24: Panelboard (floor-mounted).

Step 2: Select the type of attachment

Using the following table, select how the equipment is to be installed, select the attachment type that best matches the installation you have selected, then turn to the page under the attachment type.

Typical Equipment	How is equipment to be installed?	Attachment Type
Any type of unit	Mounted directly to the floor	Rigid Go to page 51
	Connected to angles mounted to the floor	Rigid with angles Go to page 55
	Directly to the wall	Wall-mounted Go to page 98
	Mounted to the wall with angles	Wall-mounted with angles Go to page 100
	Flush-mounted	Follow manufacturer's instructions

Table 5: Load center and panelboard installation types.



Refer to the Electrical Danger Instruction Chart on page 160.

Low Voltage: Substations, Capacitor Banks, Switchboards, and Switchgears



Be sure to refer to approved construction documents and specifications, seismic restraint submittals, and manufacturer's instructions.

Step 1: Identify the equipment



Figure 25: Substation (floor-mounted).



Figure 26: Capacitor bank (floor-mounted).



Figure 28: Low voltage switchboard (floor-mounted).



Figure 27: Low voltage switchboard (floor-mounted).



Figure 29: Low voltage switchgear (floor-mounted).

Step 2: Select the type of attachment

Using the following table, select how the equipment is to be installed, select the attachment type that best matches the installation you have selected, then turn to the page under the attachment type.

Typical Equipment	How is equipment to be installed?	Attachment Type
Any type of unit	Mounted directly to the floor	Rigid Go to page 51
	Connected to angles mounted to the floor	Rigid with angles Go to page 55
	Floor-mounted with bumpers	Floor-mounted Go to page 60
	Roof-mounted or vibration-isolated on a roof	Roof-mounted Go to page 65
	Vibration-isolated	Vibration-isolated/floor-mounted Go to page 87

Table 6: Low voltage: substation, capacitor bank, switchboard, and switchgear installation types.



Refer to the Electrical Danger Instruction Chart on page 160.

Medium to High Voltage: Switchgears, Circuit Interrupters, Substation Circuit Breakers, and Walk-in Enclosures



Be sure to refer to approved construction documents and specifications, seismic restraint submittals, and manufacturer's instructions.

Step 1: Identify the equipment



Figure 30: Medium voltage arc-resistant switchgear (floor-mounted).



Figure 31: High voltage circuit interrupter (floor-mounted).



Figure 32: Substation circuit breaker.



Figure 33: Walk-in enclosure.

Step 2: Select the type of attachment

Using the following table, select how the equipment is to be installed, select the attachment type that best matches the installation you have selected, then turn to the page under the attachment type.

Typical Equipment	How is equipment to be installed?	Attachment Type
Any type of unit	Mounted directly to the floor	Rigid Go to page 51
	Connected to angles mounted to the floor	Rigid with angles Go to page 55
	Floor-mounted with bumpers	Floor-mounted Go to page 60
	Roof-mounted or vibration-isolated on a roof	Roof-mounted Go to page 65
	Vibration-isolated	Vibration-isolated/ floor-mounted Go to page 87

Table 7: Medium to high voltage: switchgear, circuit interrupter, substation circuit breaker, and walk-in enclosure installation types.



Refer to the Electrical Danger Instruction Chart on page 160.

Meters and Disconnects



Be sure to refer to approved construction documents and specifications, seismic restraint submittals, and manufacturer’s instructions.

Step 2: Select the type of attachment

Using the following table, select how the equipment is to be installed, select the attachment type that best matches the installation you have selected, then turn to the page under the attachment type.

Typical Equipment	How is equipment to be installed?	Attachment Type
Any type of unit	Mounted directly to the floor	Rigid Go to page 51
	Connected to angles mounted to the floor	Rigid with angles Go to page 55
	Directly to the wall	Wall-mounted Go to page 98
	Mounted to the wall with angles	Wall-mounted with angles Go to page 100
	Connected to companion equipment	Follow manufacturer’s instructions

Table 8: Meter and disconnect installation types.



Refer to the Electrical Danger Instruction Chart on page 160.

Step 1: Identify the equipment



Figure 34: Meter center (floor-mounted).



Figure 35: Meter center (surface-mounted).



Figure 36: Safety switch (surface-mounted).



Figure 37: Double throw safety switch (surface-mounted).

Motor Control Centers and Variable Frequency Drives



Be sure to refer to approved construction documents and specifications, seismic restraint submittals, and manufacturer's instructions.

Step 1: Identify the equipment



Figure 38: Low voltage motor control center (floor-mounted).



Figure 39: Medium voltage motor control center (floor-mounted).



Figure 40: Enclosed motor (wall-mounted).



Figure 41: Variable frequency drive (wall-mounted).

Step 2: Select the type of attachment

Using the following table, select how the equipment is to be installed, select the attachment type that best matches the installation you have selected, then turn to the page under the attachment type.

Typical Equipment	How is equipment to be installed?	Attachment Type
Any type of unit	Mounted directly to the floor	Rigid Go to page 51
	Connected to angles mounted to the floor	Rigid with angles Go to page 55
	Directly to the wall	Wall-mounted Go to page 98
	Mounted to the wall with angles	Wall-mounted with angles Go to page 100
	Vibration-isolated	Floor-mounted Go to page 87
	Connected to companion equipment	Wall-mounted with angles Go to page 102
		Follow manufacturer's instructions

Table 9: Motor control center and variable frequency drive installation types.



Refer to the Electrical Danger Instruction Chart on page 160.

Multi-media Racks



Be sure to refer to approved construction documents and specifications, seismic restraint submittals, and manufacturer's instructions.

Step 1: Identify the equipment



Figure 42: Computer rack with or without rollers (floor-mounted).



Figure 43: Equipment rack with or without rollers (floor-mounted).



Figure 44: Open rack (floor-mounted).



Figure 45: Media equipment (wall-mounted).

Step 2: Select the type of attachment

Using the following table, select how the equipment is to be installed, select the attachment type that best matches the installation you have selected, then turn to the page under the attachment type.

Typical Equipment	How is equipment to be installed?	Attachment Type
Any type of unit	Mounted directly to the floor	Rigid Go to page 51
	Connected to angles mounted to the floor	Rigid with angles Go to page 55
	Directly to the wall	Wall-mounted Go to page 98
	Mounted to the wall with angles	Wall-mounted with angles Go to page 100
	Connected to companion equipment	Follow manufacturer's instructions

Table 10: Multi-media rack installation types.



Refer to the Electrical Danger Instruction Chart on page 160.



Rollers must be constructed to withstand additional forces created by earthquakes.

Transformers



Be sure to refer to approved construction documents and specifications, seismic restraint submittals, and manufacturer's instructions.

Step 1: Identify the equipment



Figure 46: Dry-type transformer (wall-mounted).

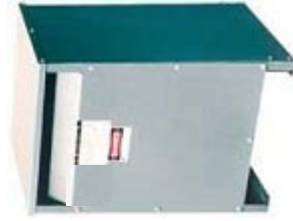

Figure 47: Dry-type transformer (floor-mounted).



Figure 48: Substation dry-type transformer.



Figure 49: Substation liquid-filled transformer.

Step 2: Select the type of attachment

Using the following table, select how the equipment is to be installed, select the attachment type that best matches the installation you have selected, then turn to the page under the attachment type.

Typical Equipment	How is equipment to be installed?	Attachment Type
Any type of unit	Mounted directly to the floor	Rigid Go to page 51
	Connected to angles mounted to the floor	Rigid with angles Go to page 55
	Using bumpers	Floor-mounted with bumpers Go to page 60
	Directly to the wall	Wall-mounted Go to page 98
	Mounted to the wall with angles	Wall-mounted with angles Go to page 100
	Mounted to the wall with vibration isolation	Wall-mounted, vibration-isolated Go to page 102
	Vibration-isolated	Vibration-isolated/floor-mounted Go to page 87
	Roof-mounted	Roof-mounted Go to page 65

Table 11: Transformer installation types.



Refer to the Electrical Danger Instruction Chart on page 160.

Uninterruptable Power Supplies and Battery Racks



Be sure to refer to approved construction documents and specifications, seismic restraint submittals, and manufacturer's instructions.

Step 1: Identify the equipment



Figure 50: UPS in multi-media rack.



Figure 51: UPS (wall-mounted).



Figure 52: UPS (floor-mounted).

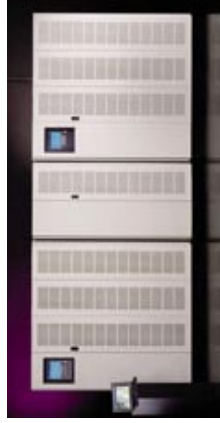

Figure 53: UPS (floor-mounted).



Figure 54: Open battery rack.



Figure 55: Cabinet battery rack.

Step 2: Select the type of attachment

Using the following table, select how the equipment is to be installed, select the attachment type that best matches the installation you have selected, then turn to the page under the attachment type.

Typical Equipment	How is equipment to be installed?	Attachment Type
Any type of unit	Mounted directly to the floor	Rigid Go to page 51
	Connected to angles mounted to the floor	Rigid with angles Go to page 55
	On a raised floor	On a raised floor Go to page 61
	Directly to the wall	Wall-mounted Go to page 98
	Mounted to the wall with angles	Wall-mounted with angles Go to page 100
	Mounted to the wall with vibration isolation	Wall-mounted, vibration-isolated Go to page 102
	Vibration-isolated	Vibration-isolated/floor-mounted Go to page 87
	Roof-mounted	Roof-mounted Go to page 65

Table 12: Uninterruptable power supply and battery rack installation types.



Refer to the Electrical Danger Instruction Chart on page 160.



Batteries must be restrained in the racks. See manufacturer's instructions.



Follow the manufacturer's instructions for field-erected battery racks.

Unit Heaters and Tanks



Be sure to refer to approved construction documents and specifications, seismic restraint submittals, and manufacturer's instructions.

Step 1: Identify the equipment

This manual covers unit heaters suspended from the building structure and floor-mounted tanks in service with generators. Other tank configurations are covered in other manuals.



Figure 56: Electric unit heater.



Figure 57: Fuel oil day tank.

Step 2: Select the type of attachment

Using the following table, select how the equipment is to be installed, select the attachment type that best matches the installation you have selected, then turn to the page under the attachment type.

Typical Equipment	How is equipment to be installed?	Attachment Type
Any unit heater	Suspended from the building structure with rods and cables	Rigid with rods and cables Go to page 71
	Suspended from the building structure with angles	Rigid with angles Go to page 78
	Suspended from the building structure with isolators, rods and cables	Vibration-isolated/suspended Go to page 81
Relatively thin unit heater	Mounted to the wall with angles	Wall-mounted with angles Go to page 100
Any tank	Suspended from the building structure with two rods and cables	Two-point Go to page 84
	Mounted directly to the floor	Rigid Go to page 51

Table 13: Unit heater and tank installation types.



Refer to the Electrical Danger Instruction Chart on page 160.

RACEWAYS/CONDUITS/CABLE TRAYS

Electrical raceways include conduits and cable trays.



For post tension (pre-stressed) buildings, locate the tendons before drilling. Extreme damage may occur if a tendon is nicked or cut.



Refer to approved construction documents for details and provisions for crossing fire barriers, area separation walls/floors/roofs, smoke barriers and seismic separation joints.



Each run of conduit or cable tray must have at least one transverse supports at each end of the run and at least one longitudinal support anywhere on the run.



Pre-approved manufacturer's/industry manuals used for installation of conduit supports are required to be on the job site to ensure the correct details are being used.



Do not mix strut and cable bracing systems.

The eight ways to install raceways are:

- Supported from the floor with angles or strut system (page 31).
- Supported from the wall (page 34).
- Suspended using clevis hanger braced at the restraining bolt (page 36).
- Suspended using clevis hanger braced at the hanger rod (page 39).
- Suspended using clevis hanger and four-way cable brace (page 41).
- Suspended using conduit clamps (page 43).
- Suspended with a trapeze support system (page 47).
- Crossing seismic joints (page 50).

Supported from the floor

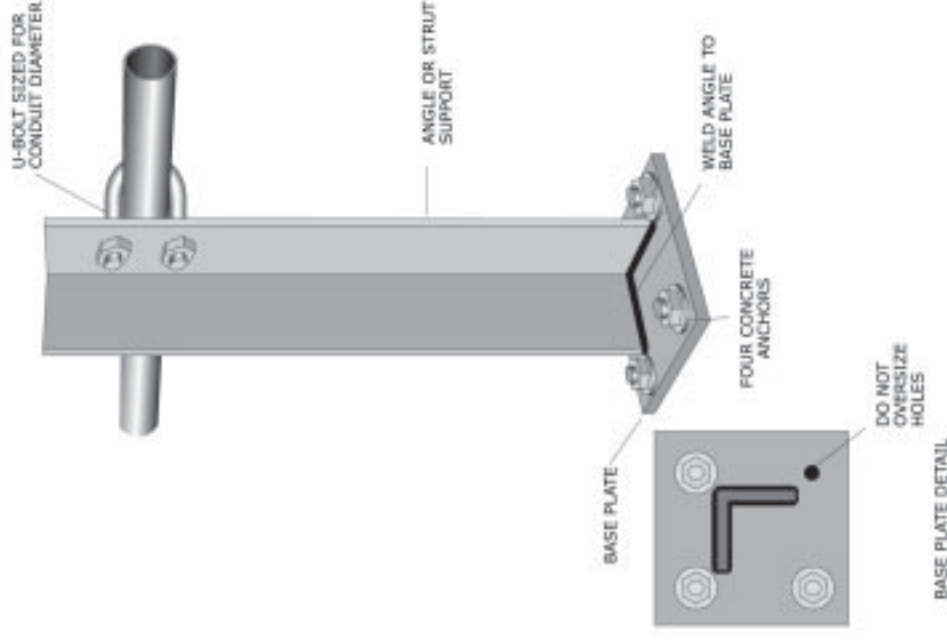
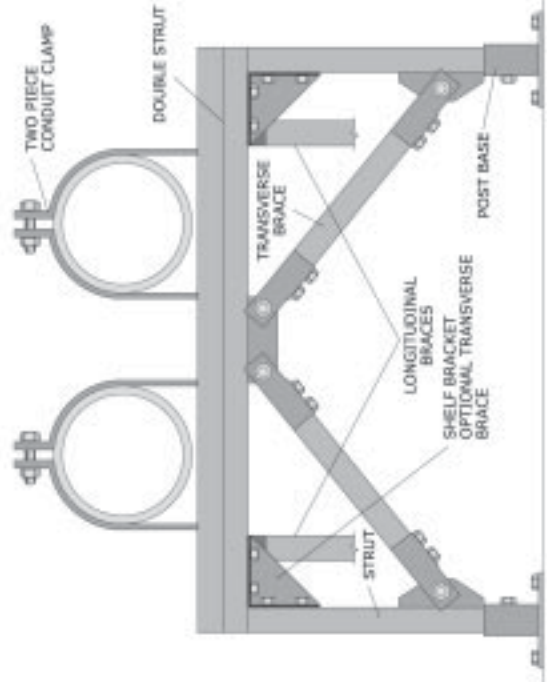
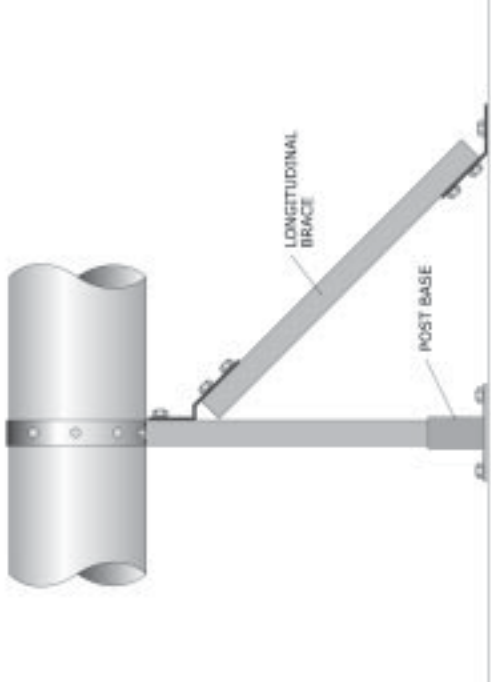

Figure 58: Single vertical support.

Use the instructions on page 35 for installing rigid supports.



Laterally braced raceways/conduit/cable trays



Axially braced raceways/conduit/cable trays

Figure 59: Braced raceways/conduit/cable trays supported from strut.

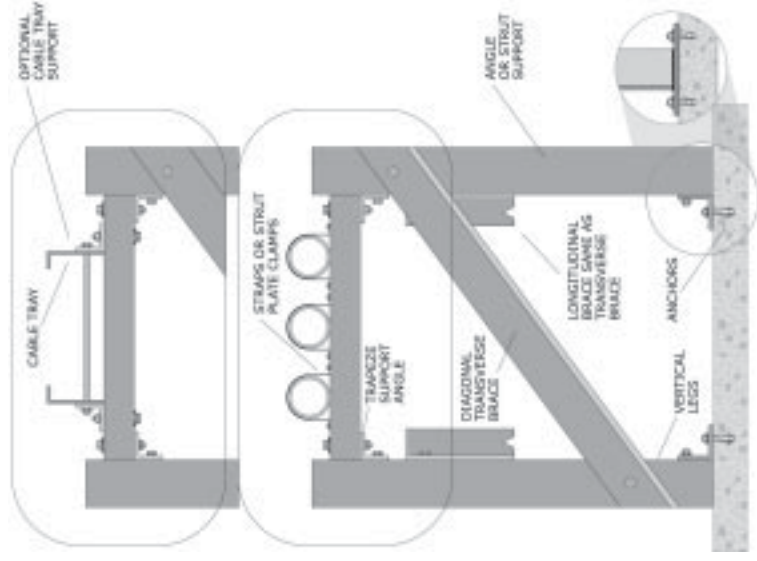

Figure 60: Attachment to a floor with a trapeze support system.

Step 1: Determine dimensions of trapeze support

Match trapeze support with the bottom of the conduit. Ensure that the width of the support allows clearance for installing clamps.

Step 2: Build trapeze support

Step 3: Determine where to drill holes in floor

Coordinate the support base hole locations with the location of any steel reinforcements or tendons.



Building structures must be point load capable. Verify with the appropriate design professional.

Step 4: Install anchors

For instructions on installing anchors, see Anchors (page 104).

Step 5: Run conduit and install conduit clamps

Secure cable tray to strut or angle with one- or two-hole brackets provided with the cable tray, or use two half angles.

END OF ATTACHMENT.

Supported from the wall

The instructions below should also be used for conduit that is surface-mounted on the underside of a building structural slab or rated structural ceiling.

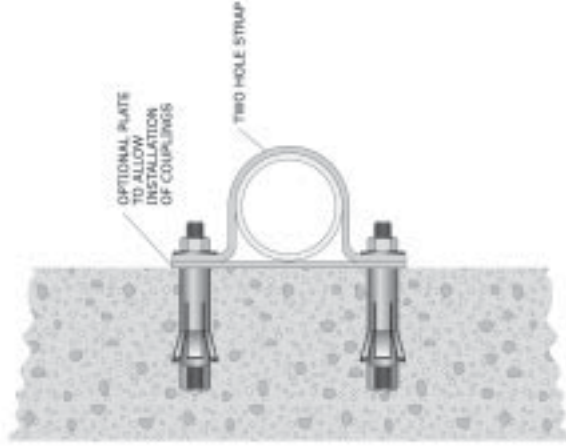

Figure 61: Direct attachment

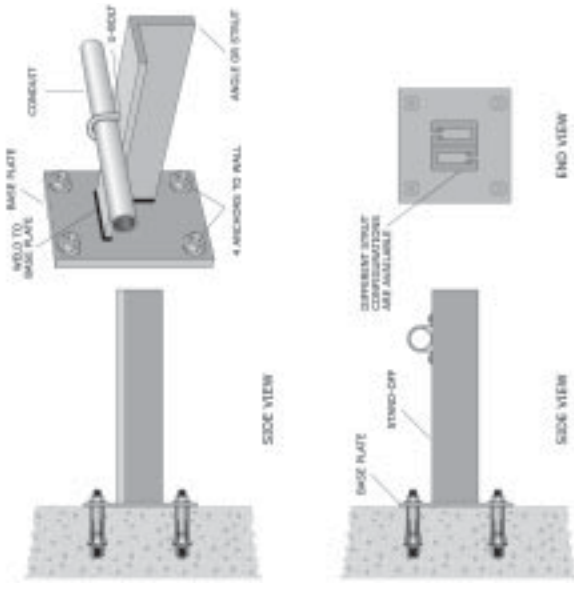

Figure 62: Attach to the wall with angle or strut welded to base plate.

Step 1: Attach support or angles to the wall

For instructions on installing anchors, see Anchors (page 104).



Building structures must be point load capable. Verify with the appropriate design professional.

For drywall attachments, use a strut attachment to the studs as shown in Figure 157 (page 142).

Step 2: Attach conduits to support with straps



The length of standoff as shown on approved construction documents or manufacturer's manuals must be rated for applied conduit weight.

END OF ATTACHMENT.

Suspended using clevis hanger braced at the restraining bolt

Step 1: Attach vertical rods with hanger to the building structure

Lay out all attachment points before anchoring. For building structure attachment details, see Figures 92 through 98 (pages 71 to 75). For instructions on installing anchors, see Anchors (page 104).

 **Building structures must be point load capable. Verify with the appropriate design professional.**

Step 2: Run raceways or conduits as required by the approved construction documents

Step 3: Attach anchors to the building structure for lateral support restraints



Refer to the pre-approved manufacturer's/industry manuals for spacing of supports.

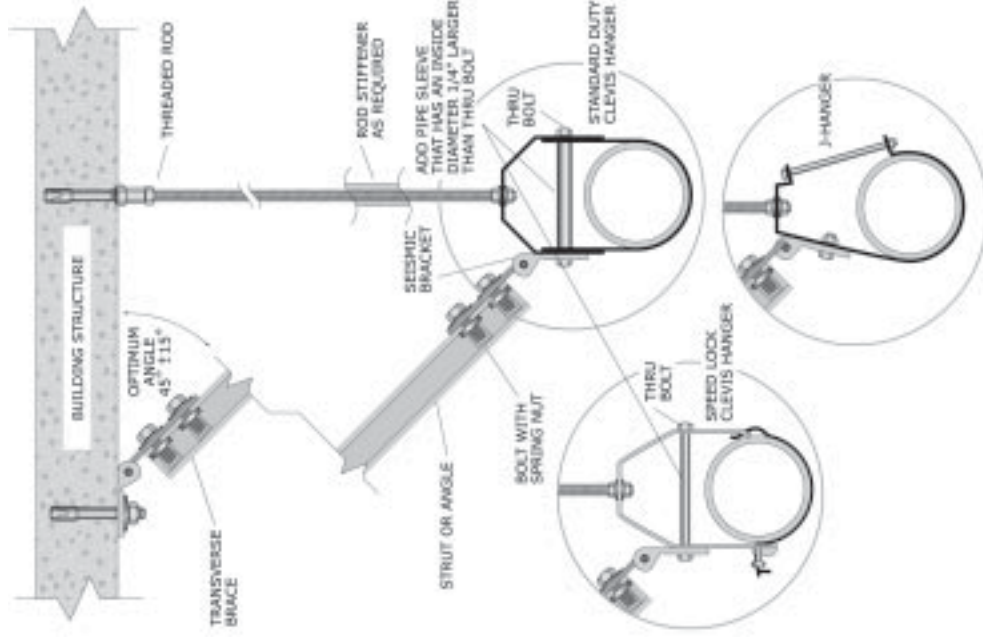

Figure 63: Single clevis hanger support with strut or angle lateral supports at the restraining bolt.



Pre-approved manufacturer's/industry manuals may limit the maximum transverse and longitudinal angles to 45 degrees.



Torque bolts per manufacturer's recommendations.

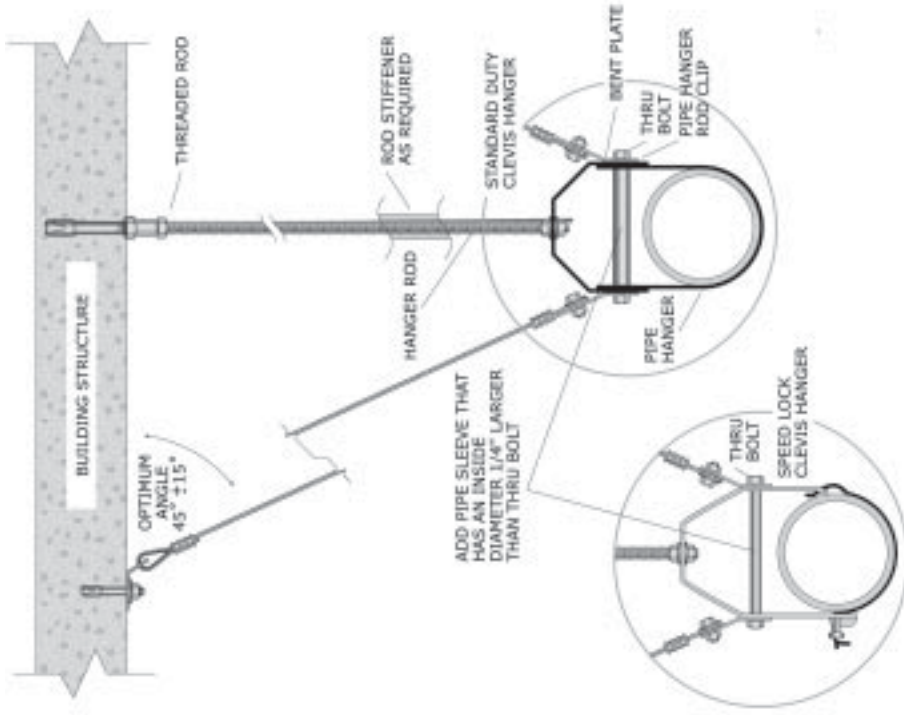

Figure 64: Single clevis hanger support with cable lateral supports at the restraining bolt.

For cable assembly instructions, see Cables (page 133). For details on attaching cable to the building structure, see Figure 100 (page 77). For angle and strut attachment, see Figure 103 (page 79). For instructions on installing anchors, see Anchors (page 104).



Torque bolts per manufacturer's recommendations.

END OF ATTACHMENT.

Suspended using clevis hanger braced at the hanger rod

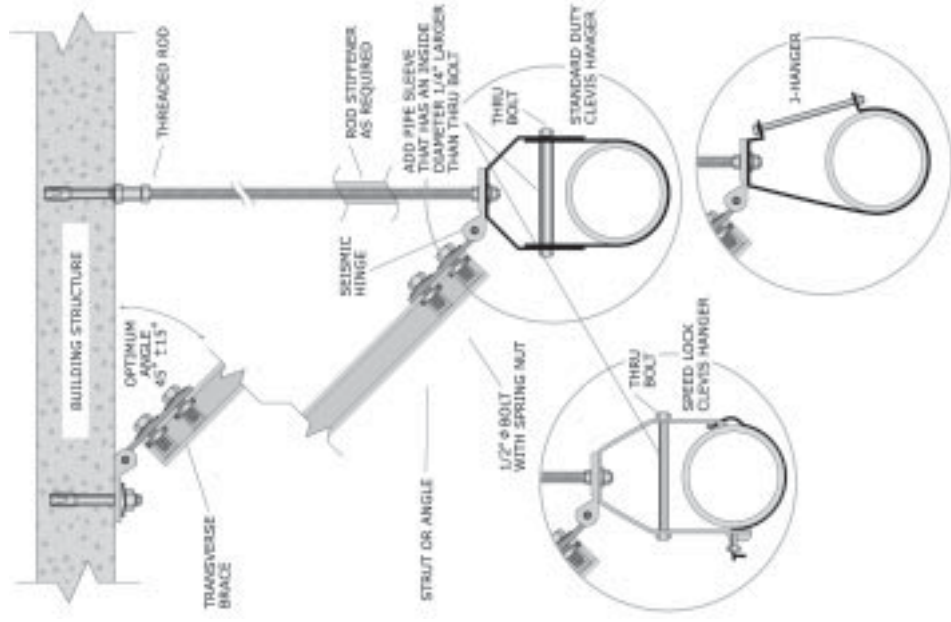

Figure 65: Single clevis hanger support with strut or angle lateral supports at hanger rod.



Pre-approved manufacturer's/industry manuals may limit the maximum transverse and longitudinal angles to 45 degrees.



Torque bolts per manufacturer's recommendations.

Step 1: Attach vertical rods with hanger to the building structure

Lay out all attachment points before anchoring. For building structure attachment details, see Figures 92 through 98 (pages 71 to 75). For direct attachment to building structure, see Anchors (page 104).



Building structures must be point load capable. Verify with the appropriate design professional.

Step 2: Run conduits as required by the approved construction documents

Step 3: Attach anchors to the building structure for lateral support restraints

For cable assembly instructions, see Cables (page 133). For details on attaching cable to the building structure, see Figure 100 (page 77). For angle and strut attachment, see Figure 103 (page 79). For instructions on installing anchors, see Anchors (page 104).

Step 4: Attach cables to conduit

END OF ATTACHMENT.

Suspended using clevis hanger and four-way cable brace

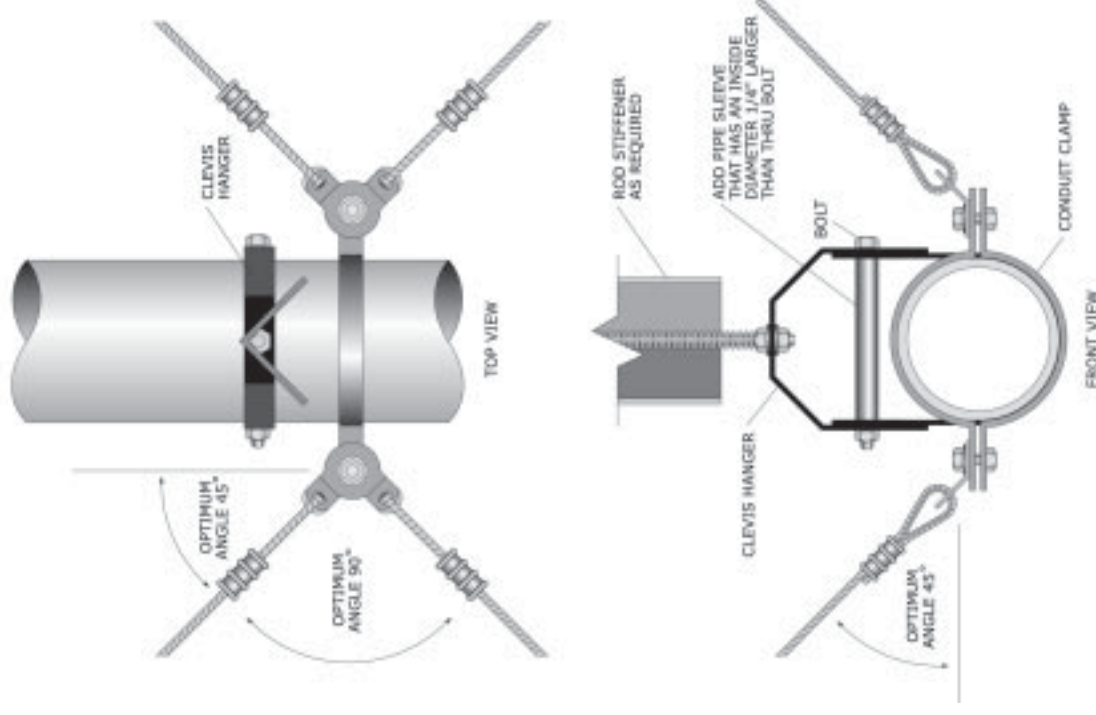

Figure 66: Single clevis hanger with four-way cable brace.

Step 1: Attach vertical rods with hanger to the building structure

Lay out all attachment points before anchoring. For building structure attachment details, see Figures 92 through 98 (pages 71 to 75). For instructions on installing anchors, see Anchors (page 104).

 **Building structures must be point load capable. Verify with the appropriate design professional.**

Step 2: Run conduits as required by the approved construction documents

Step 3: Attach anchors to the building structure for lateral support restraints

For cable assembly instructions, see Cables (page 133). For details on attaching cable to the building structure, see Figure 100 (page 77). For angle and strut attachment, see Figure 103 (page 79). For instructions on installing anchors, see Anchors (page 104).

END OF ATTACHMENT.

Suspended using conduit clamps

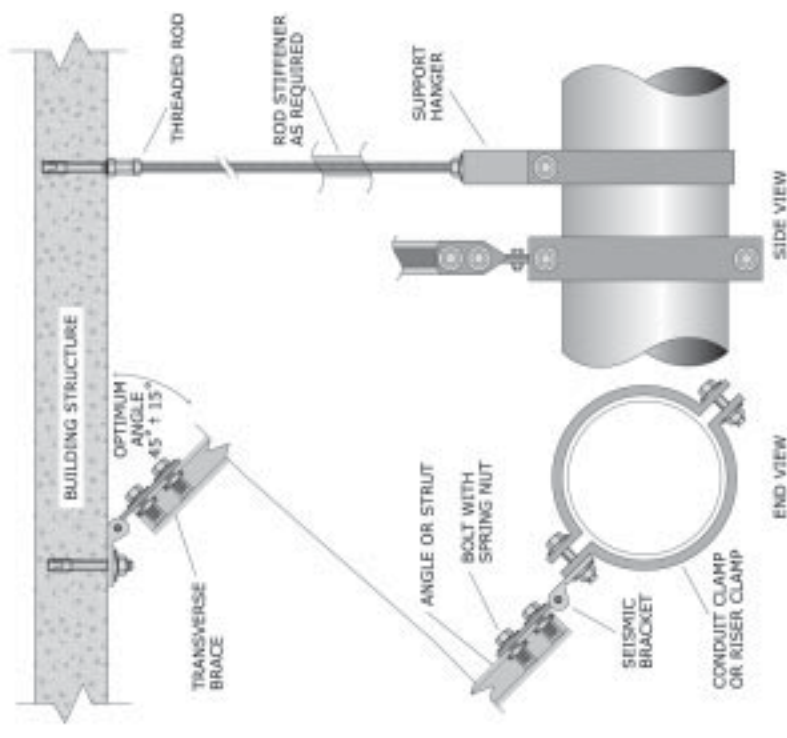

Figure 67: Conduit clamp supports with transverse strut or angle lateral support and hanger rod.

 **Pre-approved manufacturer's/industry manuals may limit the maximum transverse and longitudinal angles to 45 degrees.**

 **Torque bolts per manufacturer's recommendations.**

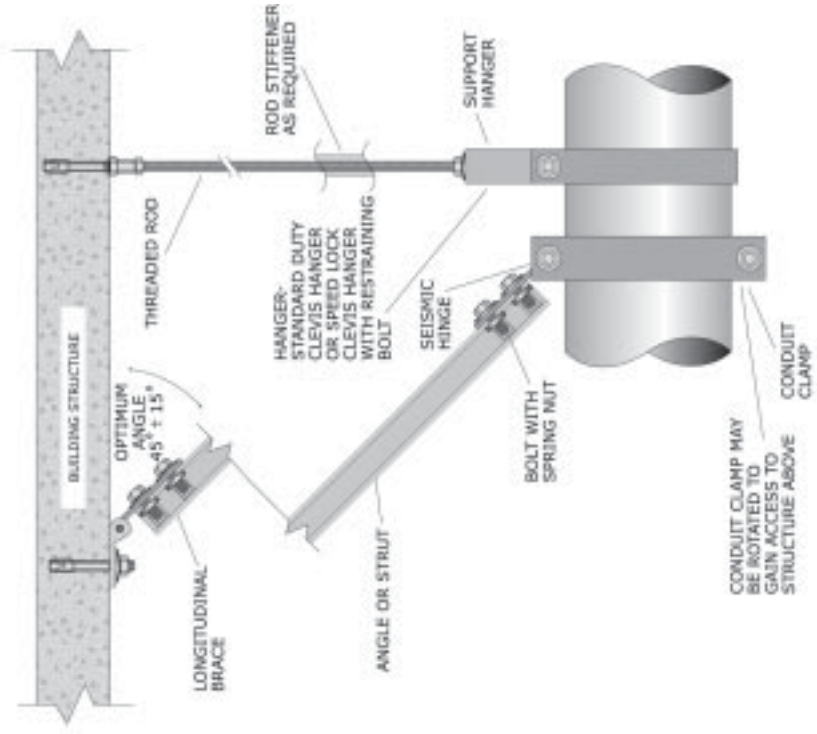

Figure 68: Conduit clamp supports with longitudinal strut or angle lateral support and hanger rod.



Pre-approved manufacturer's/industry manuals may limit the maximum transverse and longitudinal angles to 45 degrees.



Torque bolts per manufacturer's recommendations.

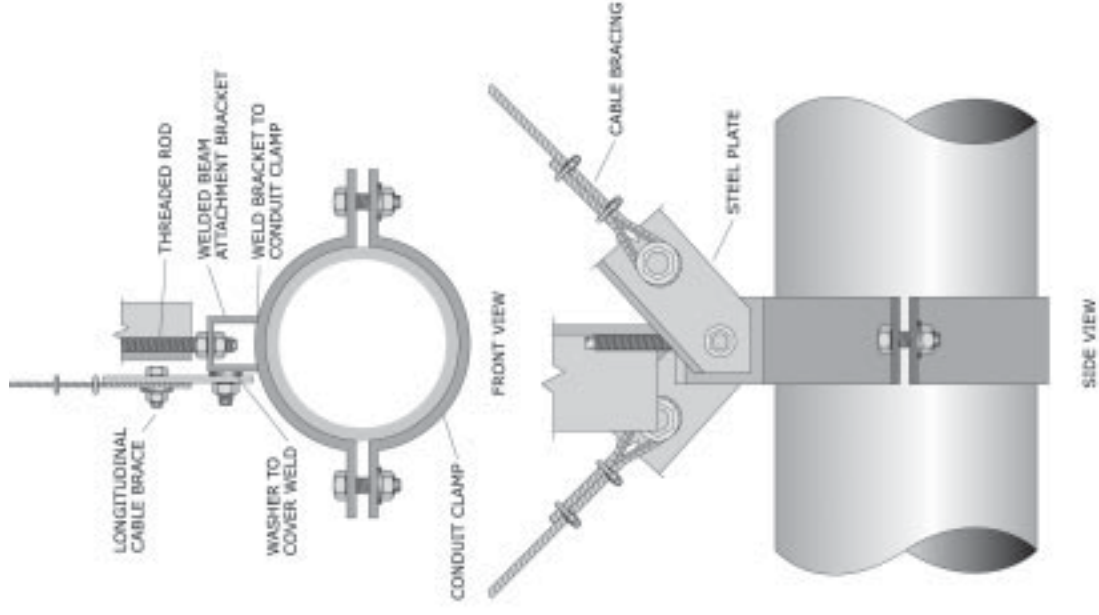

Figure 69: Conduit clamp supports with longitudinal cable lateral support and hanger rod.

Step 1: Attach vertical rods with hanger to the building structure

Lay out all attachment points before anchoring. For building structure attachment details see Figures 92 through 98 (pages 71 to 75). For instructions on installing anchors, see Anchors (page 104).

 **Building structures must be point load capable. Verify with the appropriate design professional.**

Step 2: Run conduits as required by the approved construction documents

Step 3: Attach anchors to the building structure for lateral support restraints

For cable assembly instructions, see Cables (page 133). For details on attaching cable to the building structure, see Figure 100 (page 77). For angle and strut attachment, see Figure 103 (page 79). For instructions on installing anchors, see Anchors (page 104).

END OF ATTACHMENT.

Suspended with a trapeze support system

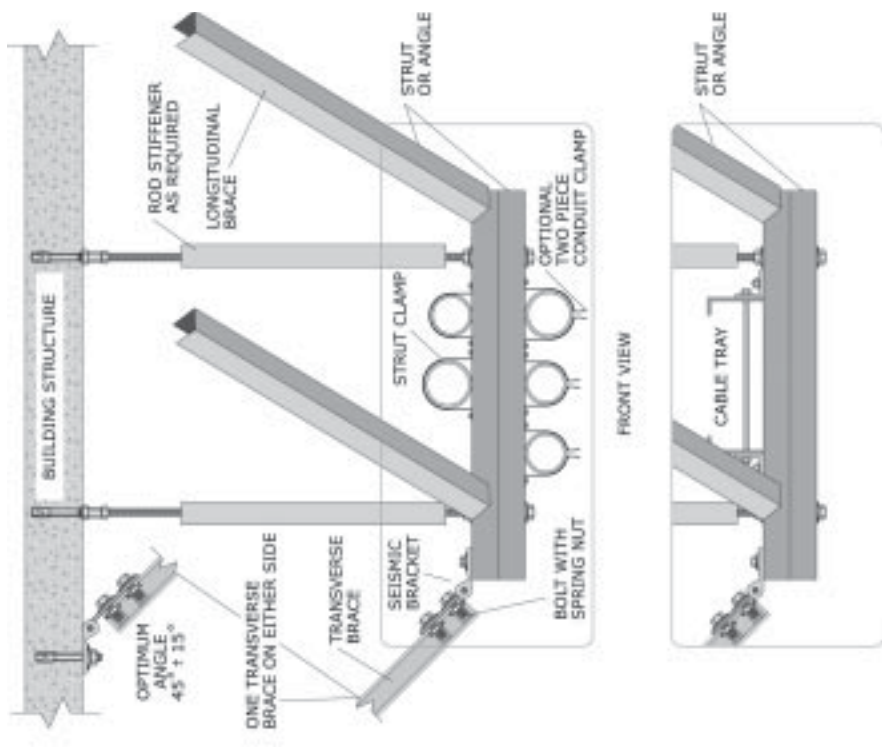

Figure 70: Trapeze support with strut or angle lateral supports.



Pre-approved manufacturer's/industry manuals may limit the maximum transverse and longitudinal angles to 45 degrees.



Torque bolts per manufacturer's recommendations.

Step 1: Attach vertical rods with hanger to the building structure

Lay out all attachment points before anchoring. For building structure attachment details, see Figures 92 through 98 (pages 71 to 75). For instructions on installing anchors, see Anchors (page 104).



Building structures must be point load capable. Verify with the appropriate design professional.

Step 2: Run conduits as required by approved construction documents

Step 3: Attach anchors to the building structure for lateral support restraints

For cable assembly instructions, see Cables (page 133). For details on attaching cable to the building structure, see Figure 100 (page 77). For angle and strut attachment, see Figure 103 (page 79). For instructions on installing anchors, see Anchors (page 104).

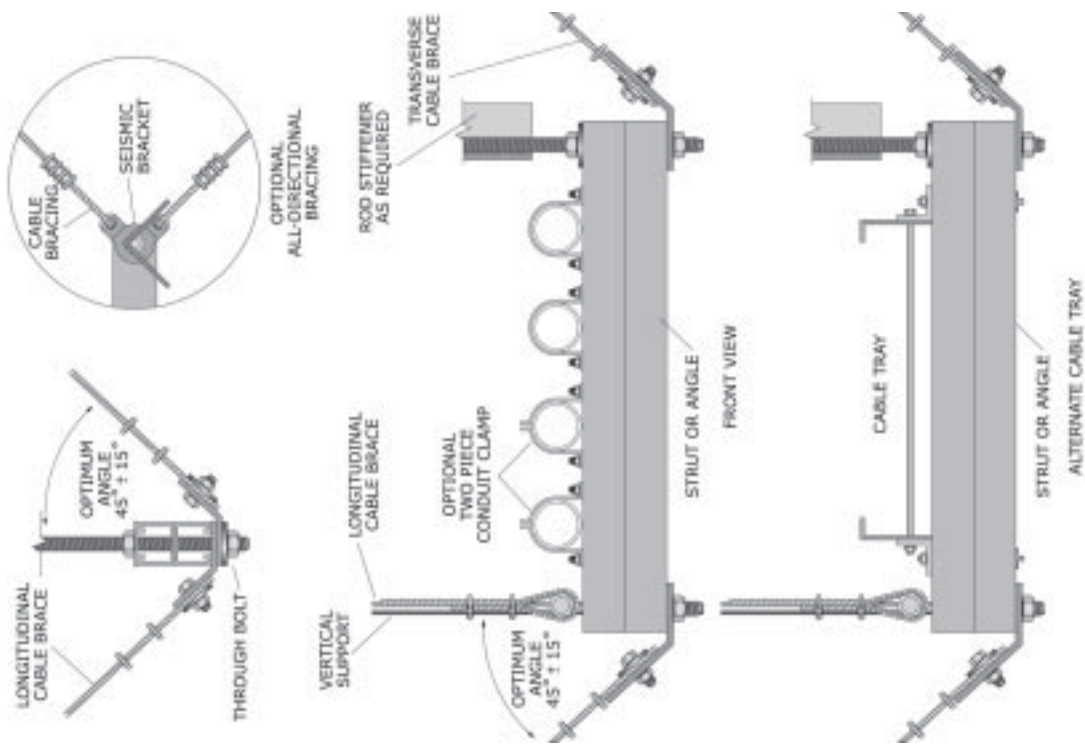

Figure 71: Trapeze support with cable lateral supports.

END OF ATTACHMENT.

Crossing seismic joints

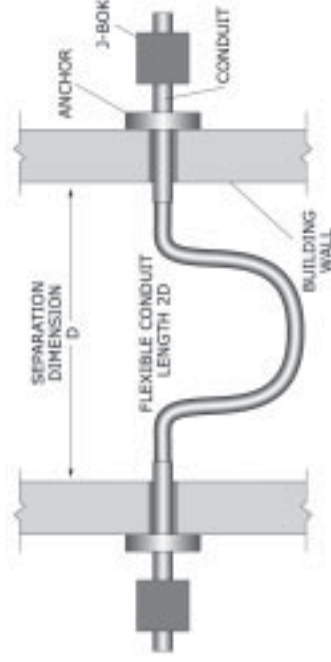

Figure 72: Seismic joint.

Step 1: Cross seismic joint with flexible conduit

Support conduits as required by approved construction documents. Add a flexible conduit support to allow differential movement in all directions.

END OF ATTACHMENT.

ATTACHMENT TYPES

This section gives instructions on attaching equipment to a building structure in various arrangements. The attachment types are:

- Rigid Floor-mounted/Pad-mounted (this page).
- Roof-mounted (page 65).
- Suspended (page 71).
- Vibration-isolated/Floor-mounted (page 87).
- Wall-mounted (page 98).

Rigid Floor-mounted/Pad-mounted Attachments

The four ways to rigidly attach equipment to a floor are:

- Directly to the floor/pad (this page).
- Using additional structural steel shapes that transfer load to the building floor/pad (page 55).
- Using bumpers to restrict horizontal movement (page 60).
- On a raised floor (page 61).

Directly to the floor /pad

Equipment may be bolted or welded to the building floor or pad. To bolt to concrete, use post-installed anchors, or embedded headed studs (see Anchors, page 104).

Attachment of equipment with sheet steel housings is shown in Figures 73 and 74 (page 52).

Attachment of equipment with a structural steel frame or base is shown in Figure 75 (page 53).

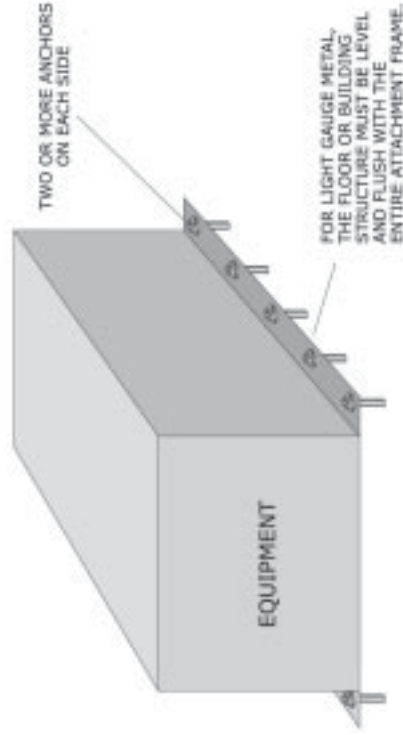

Figure 73: Direct attachment of equipment with sheet steel housing to a building.

Do not add shims under equipment with sheet steel housings as shown in Figure 73 above. If the concrete floor/pad is irregular, reinforce housing with angles as shown in Figure 77 (page 56).

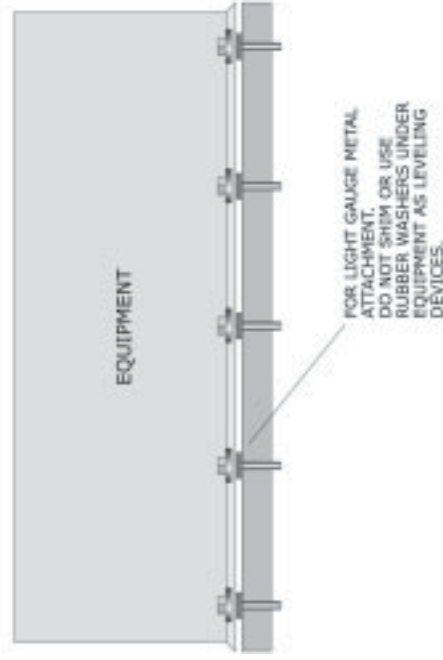

Figure 74: Side view of equipment with sheet steel housing.

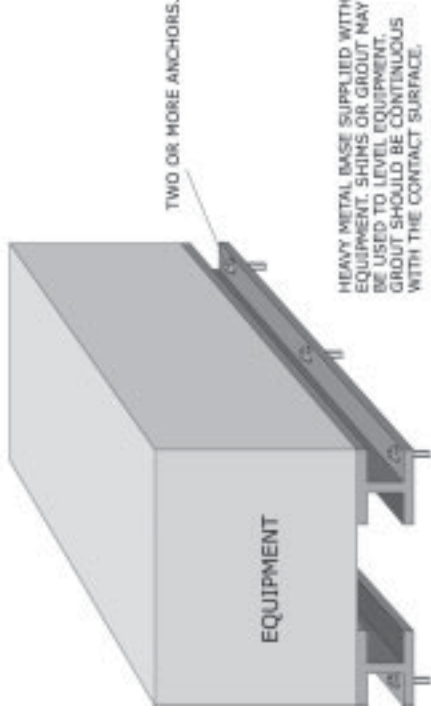

Figure 75: Direct attachment of equipment with structural steel frame or base to a building.

Step 1: Determine where to bolt the equipment

Accurately draw the bolt pattern on the floor, concrete pad, or steel beams using one of the following methods:

- Set the equipment in place and mark the holes.
- Make a template.
- Use measurements and approved construction documents to lay out the bolt hole pattern.



It is preferred to use the holes provided by the manufacturer. Under supervisory approval, you may need to drill additional holes in the equipment assembly or building steel beams as shown on approved construction documents or the manufacturer's instructions.



USE CAUTION WHEN DRILLING INTO EQUIPMENT. Internal components can be damaged or the manufacturer's warranty may be voided.



DO NOT DRILL OVERSIZED HOLES. New holes cannot be oversized or oval in shape. Repair oversized holes as shown in Figure 76 (page 54), if necessary.

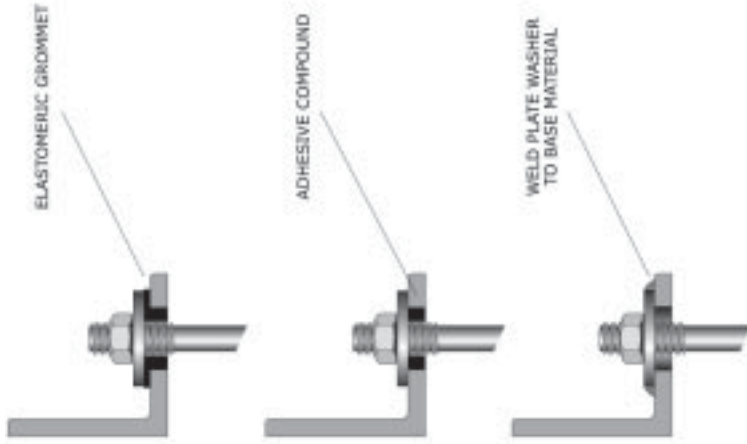

Figure 76: Three options to repair oversized holes.

Step 2: Install anchors

If the equipment is to be anchored to concrete, drill and install post-installed anchors or pour concrete with cast-in-place studs (see Anchors, page 104).



If the equipment is to be bolted to steel, drill holes in the steel as shown on approved construction documents or the manufacturer's instructions.

Step 3: Move equipment into place



BE CAREFUL NOT TO DAMAGE THE ANCHORS WHEN SETTING THE EQUIPMENT.

Step 4: Attach nuts or weld equipment

Attach nuts to the anchor/bolt and torque, see Anchors (page 104) or weld equipment to steel beams or embedded plates, see Welding (page 128).

Raceways, conduits, and cable trays may now be connected.

END OF ATTACHMENT.

Using additional structural steel shapes that transfer load to the building floor/pad

Attach additional structural shapes to the equipment with bolts and then attach steel shapes to the building with concrete anchors, steel bolts, or welding. When bolting to concrete, use post-installed anchors or embedded headed studs.

The five configurations for using angles to attach equipment to the building structure are:

- Full-size angles on each side of equipment (Figure 77, page 56).
- Four or more angles on each side of equipment bolted to the concrete floor/pad (Figure 78, page 57).
- Four or more angles welded to equipment and bolted to the floor/pad (Figure 79, page 57).
- Four or more angles on each side of equipment welded to embedded plates (Figure 80, page 58).
- Three or more angles used to bolt down equipment with a round base, (Figure 81, page 58).

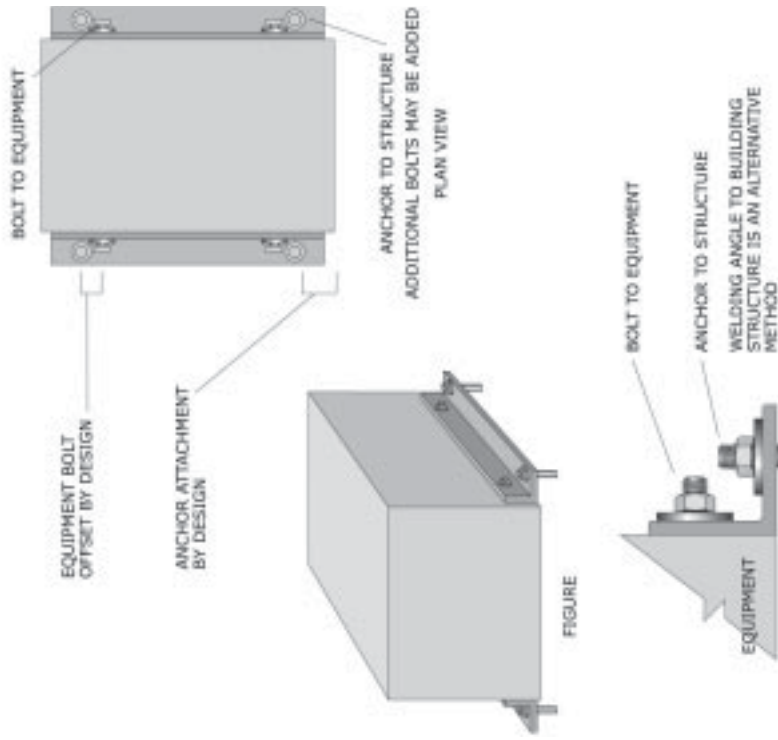

Figure 77: Two angles used to attach the equipment to the building.

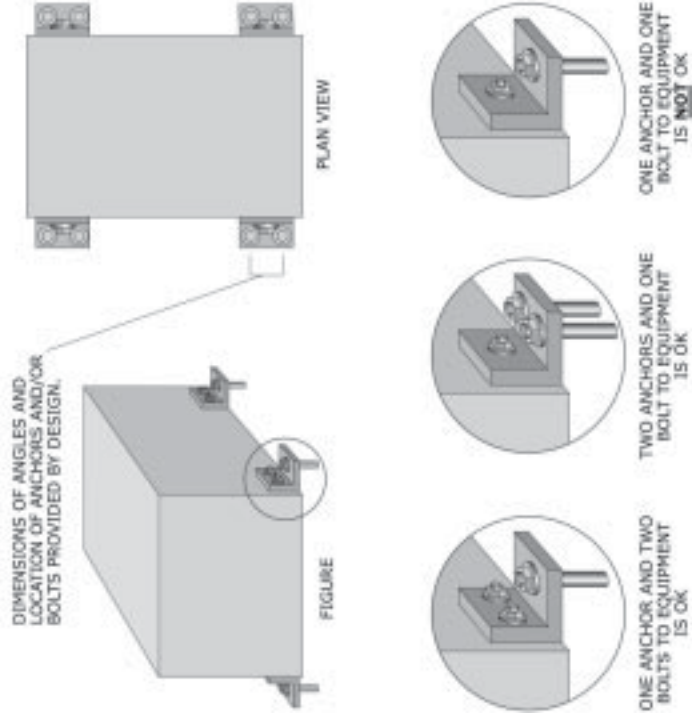

Figure 78: Four or more angles used to attach the equipment to the building.

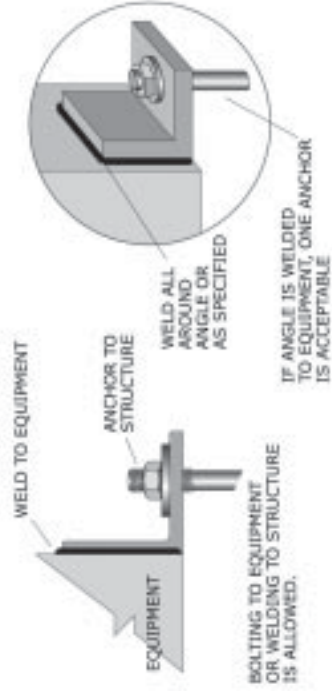

Figure 79: Four or more angles welded to equipment and bolted to the floor/pad.

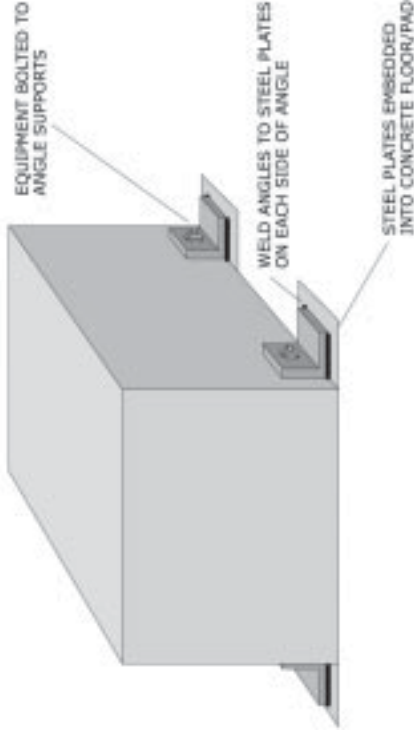

Figure 80: Four or more angles on each side of equipment welded to embedded plates. *Figure 148 (page 128) gives examples of embedded steel plates.*

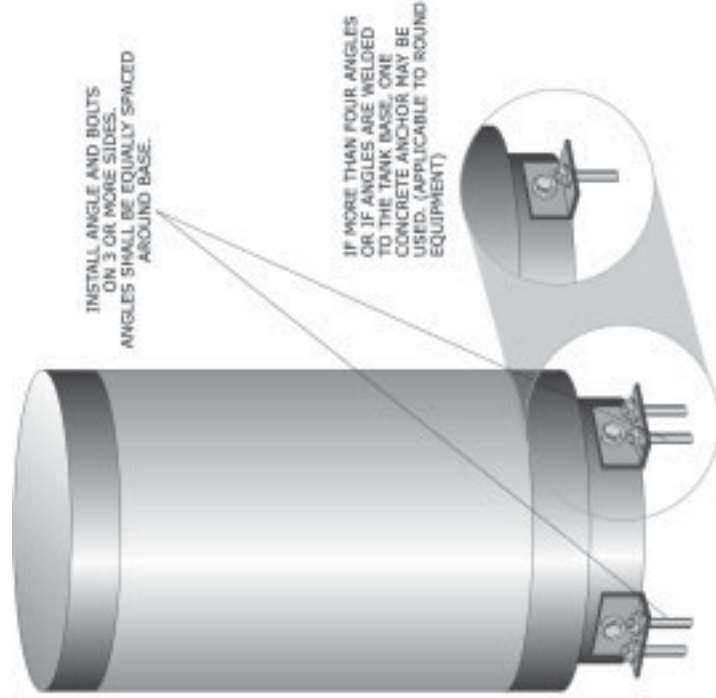

Figure 81: Three or more angles used to bolt down equipment with a round base.

Step 1: Determine where to bolt the equipment

Accurately draw the bolt pattern on the floor, concrete pad, or steel beams using one of the following methods:

- Set the equipment in place and mark the holes.
- Make a template.
- Use measurements and approved construction documents to lay out the bolt hole pattern.



It is preferred to use the holes provided by the manufacturer. Under supervisory approval, you may need to drill additional holes in the equipment assembly or building steel beams as shown on approved construction documents or the manufacturer's instructions.



USE CAUTION WHEN DRILLING INTO EQUIPMENT. Internal components can be damaged or the manufacturer's warranty may be voided.



DO NOT DRILL OVERSIZED HOLES. New holes cannot be oversized or oval in shape. Repair oversized holes as shown in Figure 76 (page 54), if necessary.

Step 2: Install anchors

If the equipment is to be anchored to concrete, drill and install post-installed anchors or pour concrete with embedded studs (see Anchors, page 104).

Step 3: Move the equipment into place



BE CAREFUL NOT TO DAMAGE THE ANCHORS WHEN SETTING THE EQUIPMENT.

You may bolt or weld angles to the equipment before moving the equipment into place.

Step 4: Attach nuts or weld equipment

Attach nuts to the anchor/bolt and torque (see Anchors, page 104 or Welding, page 128).

Raceways, conduits, and cable trays may now be connected.

END OF ATTACHMENT.

Using bumpers to restrict horizontal movement

Use this attachment type when equipment is mounted to a concrete inertia base or steel frame, but is not attached to the building. Refer to the Vibration-isolated/Floor-mounted Attachments section (page 87) for information on bumpers.

Bumpers are used to restrain the base from moving horizontally when there is no chance that the equipment will tip over. Bumpers are only bolted to the building structure. Use post-installed anchors to bolt to concrete, as shown in Figures 82 and 83 (below).

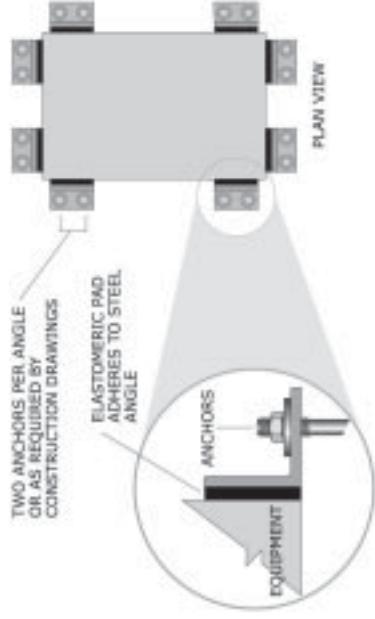

Figure 82: Equipment installed with bumpers.

If anchors are near a joint in the concrete, see detail in Figure 83.

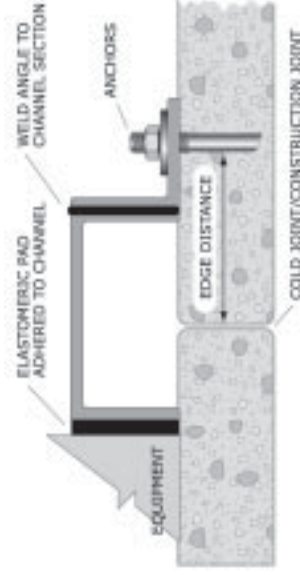

Figure 83: Alternate installation detail of bumpers installed near a concrete joint.

Step 1: Determine where to bolt the equipment

Accurately draw the bolt pattern on the floor, concrete pad, or steel beams using one of the following methods:

- Set the bumpers in place and mark the holes.
- Make a template.
- Use measurements and approved construction documents to lay out the bolt hole pattern.

Step 2: Install anchors

For instructions on installing anchors, see Anchors (page 104). If the anchors are near a concrete joint, refer to the detail in Figure 83 (page 60).

Step 3: Install bumpers

Step 4: Attach nuts to the anchor/bolt and torque

For instructions on installing anchors, see Anchors (page 104). Figure 83 (page 60) shows equipment restrained with bumpers next to a cold joint.

END OF ATTACHMENT.

On a raised floor

Equipment set on a raised floor can be seismically attached to the building structure below. A stand rated for the weight of the equipment and laterally braced to withstand seismic loads must be provided. Equipment is rigidly attached to the stand and the stand is rigidly bolted to the floor beneath the raised floor. Portions of the raised floor are removed to allow installation of the stand and equipment as shown in Figures 84 (page 62), 85 (page 63) and 86 (page 64).

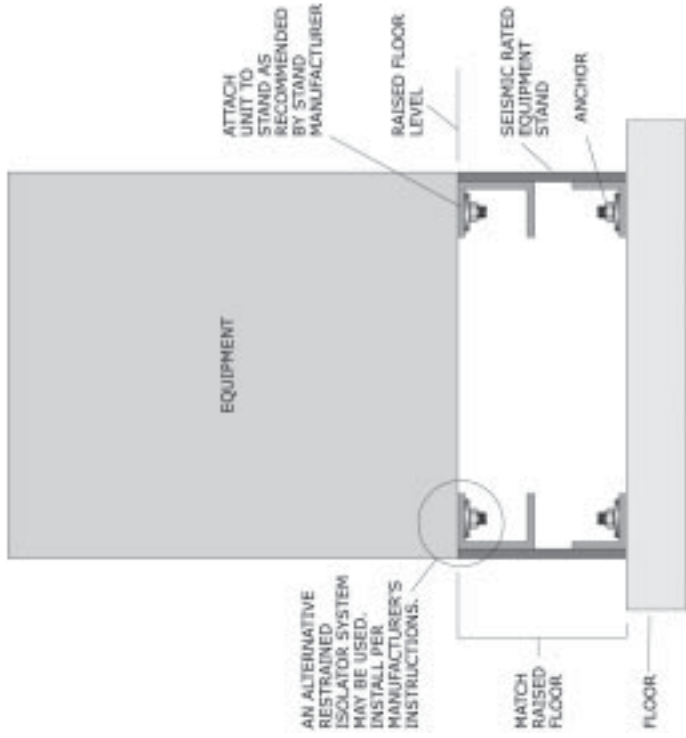

Figure 84: Electrical equipment installed on a raised floor.

Step 1: Determine where to bolt the equipment

Accurately draw the bolt pattern on the floor using one of the following methods:

- Set the frame in place and mark the holes.
- Make a template.
- Use measurements and approved construction documents to lay out the bolt hole pattern.

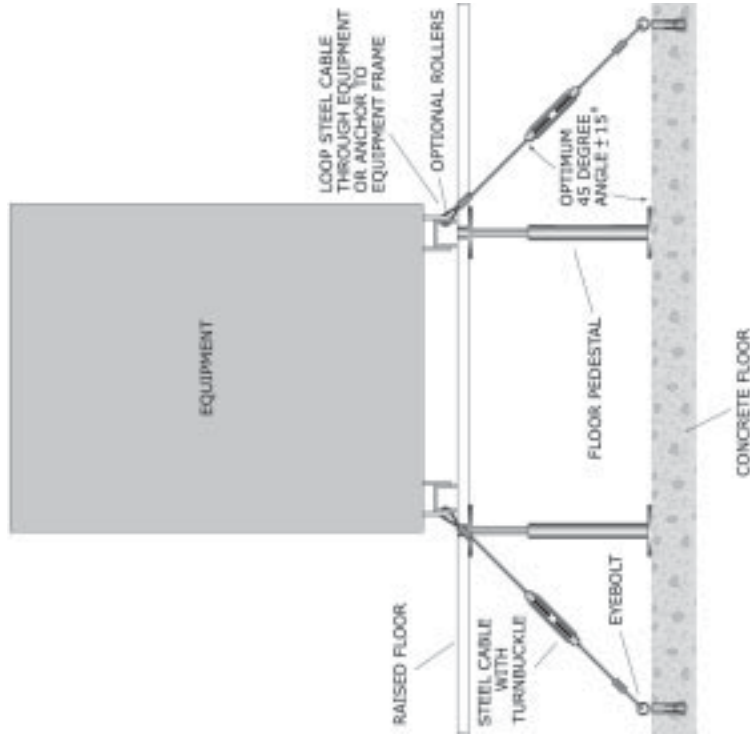

Figure 85: Equipment attached to cables beneath a raised floor.

Step 2: Install anchors

For instructions on installing anchors, see Anchors (page 104). Set the frame in place and apply nuts to the anchor/bolt and torque.



Verify with a supervisor that the weight of equipment will not exceed the capacity of the raised floor and that the floor can withstand a horizontal load.

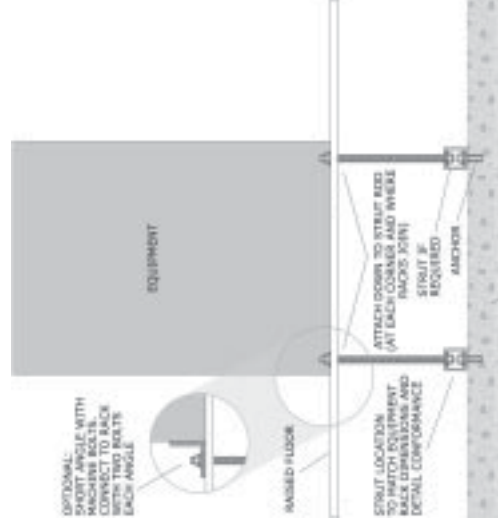

Figure 86: Equipment bolted beneath a raised floor.

Step 3: Move the equipment into place

Bolt the equipment to the frame (see Steel Bolt Connections, page 123) or bolt to strut as shown in Figure 86.



It is preferred to use the holes provided by the manufacturer. Under supervisory approval, you may need to drill additional holes in the equipment assembly or building steel beams as shown on approved construction documents or the manufacturer's instructions.



USE CAUTION WHEN DRILLING INTO EQUIPMENT. Internal components can be damaged or the manufacturer's warranty may be voided.



DO NOT DRILL OVERSIZED HOLES. New holes cannot be oversized or oval in shape. Repair oversized holes as shown in Figure 76 (page 54), if necessary.

Raceways, conduits, and cable trays may now be connected.

END OF ATTACHMENT.

Roof-mounted Attachments

The three ways to attach equipment to a roof are:

- Using leveling stanchions—post and beam (this page).
- To a wood frame (page 68).
- Using restrained vibration isolators on leveling stanchions (page 69).

Using leveling stanchions—post and beam

Step 1: Attach posts or stanchions

Bolt or weld stanchions (also called post and beam) to the building structure. To attach stanchions to different building structure types, see the detail in Figure 87 (page 66).

Support stanchions can be made from many different structural shapes.



Coordinate attachment points with approved construction documents. Additional intermediate building structure beams may be required to accommodate the equipment.



The building structure must be capable of supporting the point load of the stanchions.

Step 2: Apply flashing to stanchions

Use standard details to flash around pipe stanchions or steel tubing. For flashing around a stanchion, which may not be uniform like an angle, channel, or I-beam steel shape, see Figure 88 (page 67).

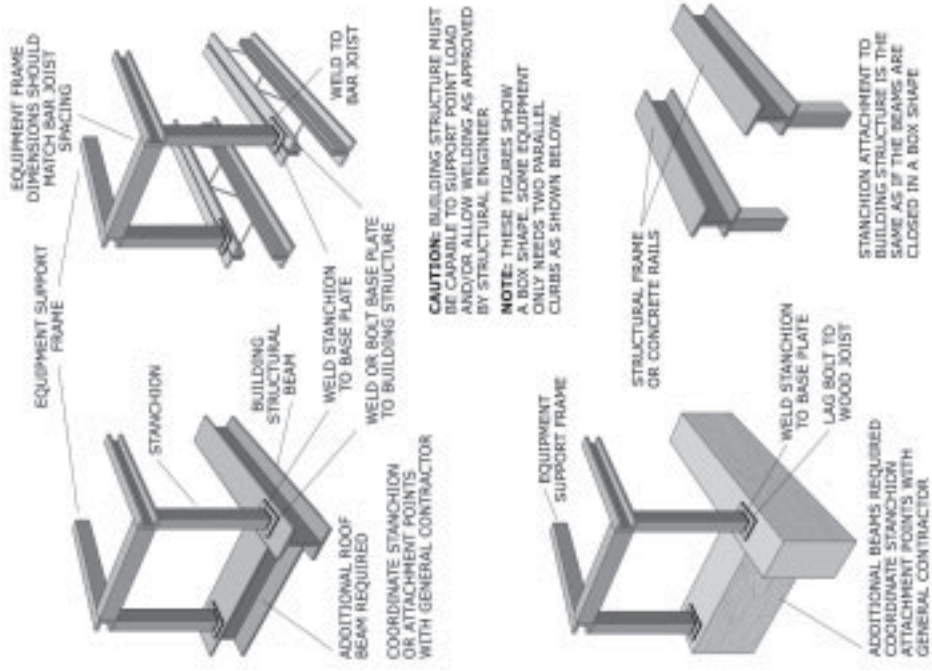

Figure 87: Attaching a stanchion to a building.

Step 3: Weld/bolt equipment support frame to stanchion

The equipment support frame may be box-shaped or have two parallel beams made from steel shapes such as angles, tubes, channels, or I-beams.

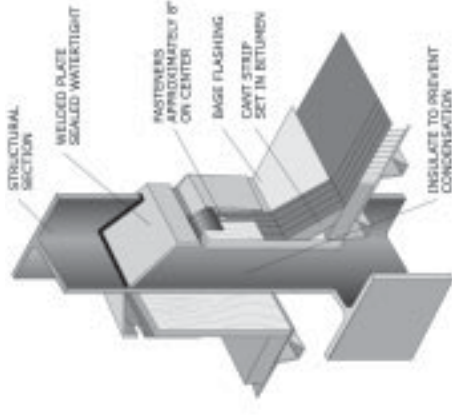

Figure 88: Flashing around a stanchion.

Step 4: Attach equipment

To rigidly attach the equipment to the equipment support frame, see Figure 89 (below).

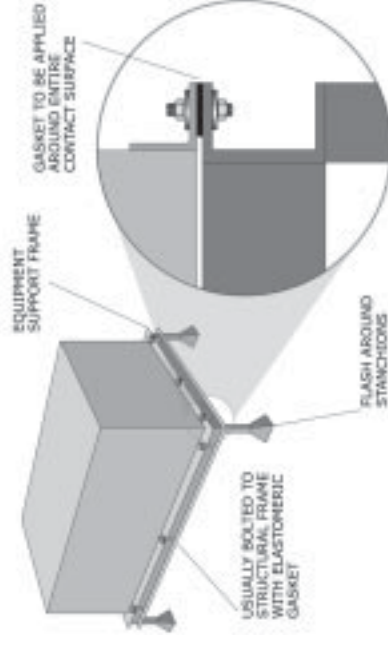

Figure 89: Rigid attachment of equipment to a support frame.

END OF ATTACHMENT.

To a wood frame

Step 1: Attach wood frame to building structure

Figure 90 (below) shows a typical wood frame (curb/rail) attachment.

Step 2: Install flashing

Figure 90 (below) shows typical flashing.



Use approved construction documents for flashing details.

Step 3: Attach equipment to the wood frame

Attach equipment directly to the wood frame as shown below. Wood frames can restrain equipment with internal frames or with support legs as shown.

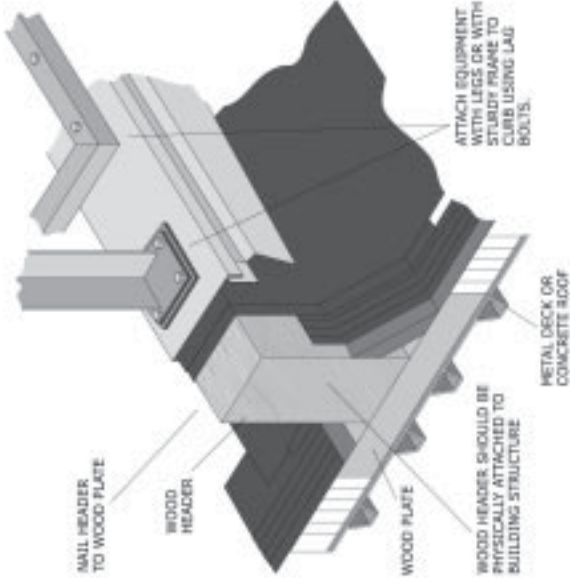

Figure 90: Attachment of equipment to a wood frame.

END OF ATTACHMENT.

Using restrained vibration isolators on leveling stanchions

Figure 91 (below) shows a typical installation of restrained vibration-isolated equipment on stanchions and an equipment support frame.

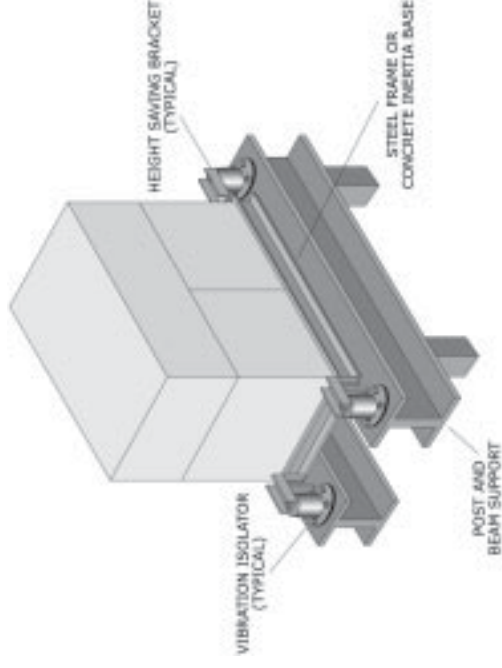

Figure 91: Equipment attached using restrained vibration isolators on a post and beam support.



More than four restrained vibration isolators may be required. See the manufacturer's instructions.



Verify that each vibration isolator is properly aligned according to the manufacturer's recommended clearances. If the vibration isolator shaft rubs against the snubber element, vibration isolation may not function or noise problems may occur.

Step 1: Attach posts or stanchions

Bolt or weld stanchions to the building structure. Refer to the detail in Figure 87 (page 66) for attaching stanchions to different building structure types. Support stanchions can be made from many different structural shapes.

Attachments: Roof-mounted



Coordinate attachment points with approved construction documents. Additional intermediate building structure beams may be required to accommodate the equipment.



The building structure must be capable of supporting the point load of the stanchions.

Step 2: Apply flashing to stanchions

Use standard details to flash around pipe stanchions or steel tubing. For flashing around a stanchion, which may not be uniform like an angle, channel, or I-beam steel shape, refer to Figure 88 (page 67).

Step 3: Weld/bolt equipment support frame to stanchions

The equipment support frame may be box-shaped or have two parallel beams. The equipment support frame may be made from steel shapes such as angles, tubes, channels, or I-beams.

Step 4: Attach restrained vibration isolators

Attach restrained vibration isolators to the support frame using steel bolts.



The support frame must be wider than the base plate of the restrained vibration isolator.

Step 5: Install equipment on vibration isolators

Install equipment on vibration isolators with attachment nuts and level.



Bases are required for mounting equipment with restrained vibration isolators.

END OF ATTACHMENT.

Suspended Attachments



Do not mix strut and cable bracing systems.

The five ways to suspend equipment are by:

- Rigid connection to the building structure using four threaded vertical rods with horizontal cable supports (this page).
- Rigid connection to the building structure using angle/strut supports (page 78).
- Vibration-isolated connection to the building structure using a minimum of four threaded vertical rods and lateral restraints (page 81).
- Two point equipment attachment - bolted to the building structure (page 84).
- Chain mounted or bar support with swivel (page 86).

Rigid connection to the building structure using four threaded vertical rods with horizontal cable supports

Equipment should have pre-installed brackets that can support the attachment to the building.

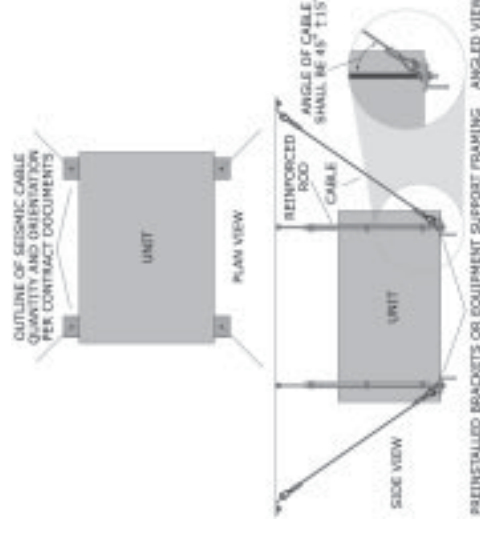

Figure 92: Rigid connection to the building structure.



Cables provide lateral bracing for seismic loads and should not be installed to hang equipment.

Step 1: Attach the equipment to the building structure using threaded rods and anchors

Lay out all attachment points before anchoring. For building structure attachment details, see Figures 92 to 98 (pages 71 to 75). For instructions on bolting directly to the building structure, see Steel Bolt Connections (page 123).

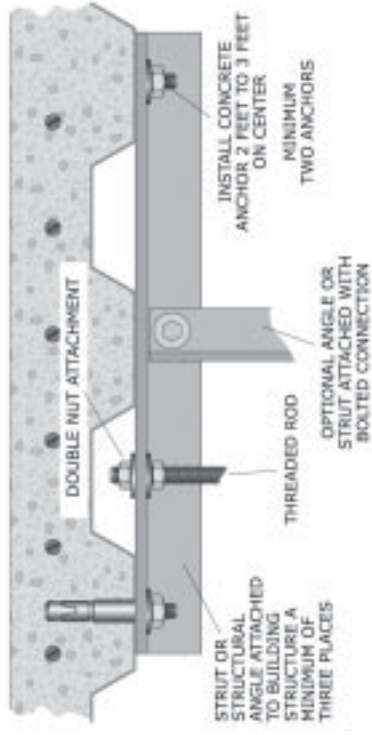

Figure 94: Post-installed anchor; concrete fill on steel deck.

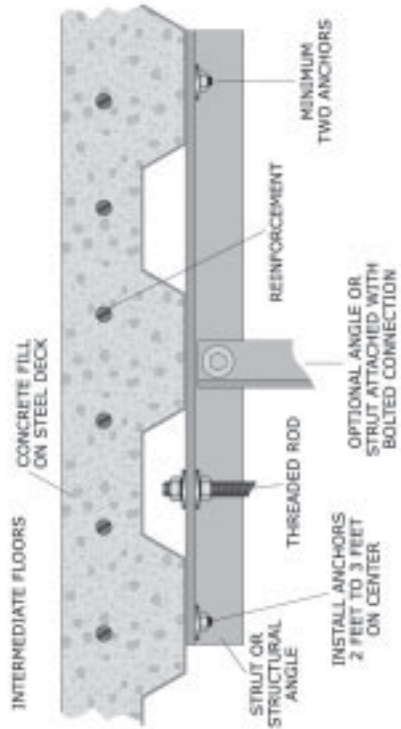

Figure 93: Cast-in-place anchor; concrete fill on steel deck.

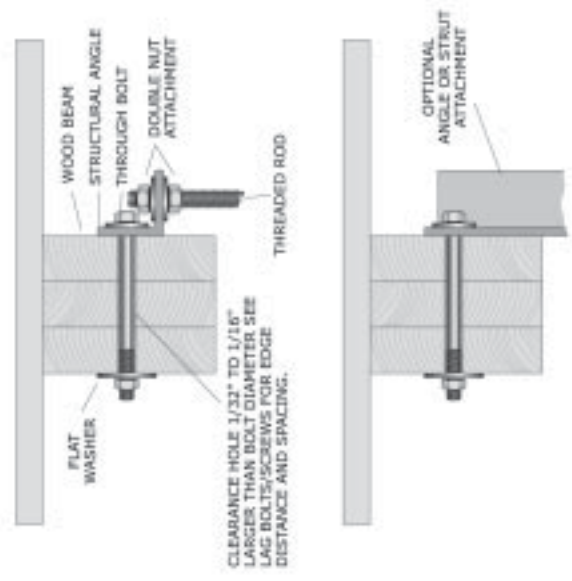

Figure 95: Wood beam construction.



For edge distances and spacing, see Lag Bolts (page 112).

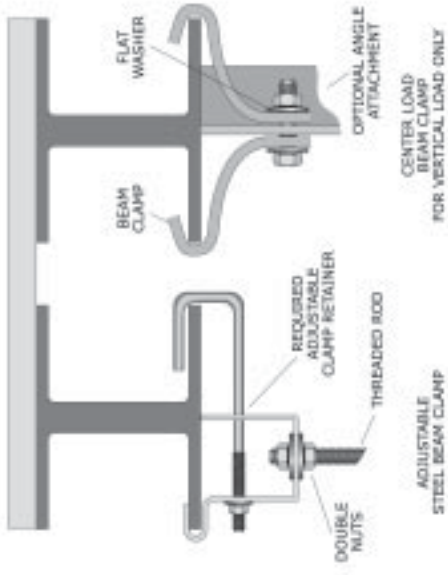

Figure 96: Steel beam construction.



Use center load beam clamps for vertical loads. Do not use for cables, rods, or structural members positioned at an angle.

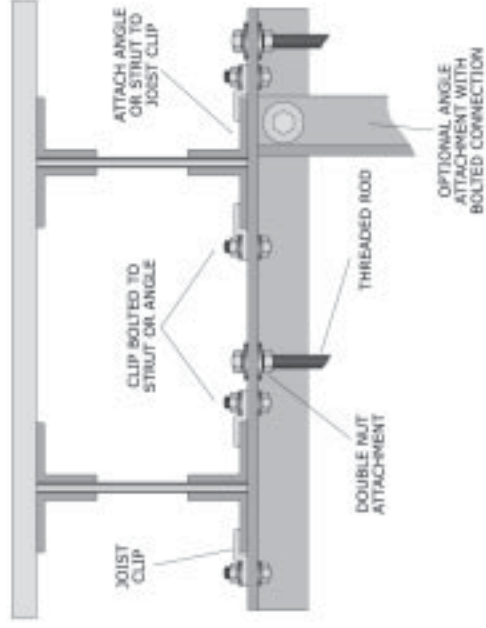

Figure 97: Bar joist construction.



Use center load beam clamps for vertical loads. Do not use for cables, rods, or structural members positioned at an angle.

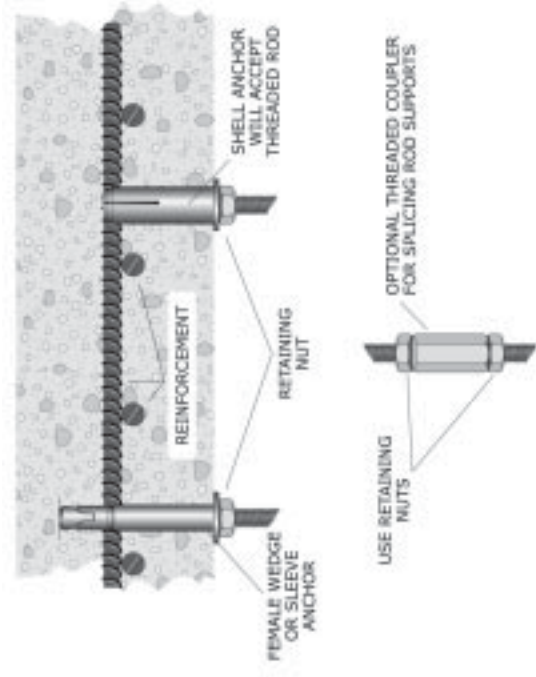

Figure 98: Concrete slab construction.

Step 2: Add rod stiffeners, as required

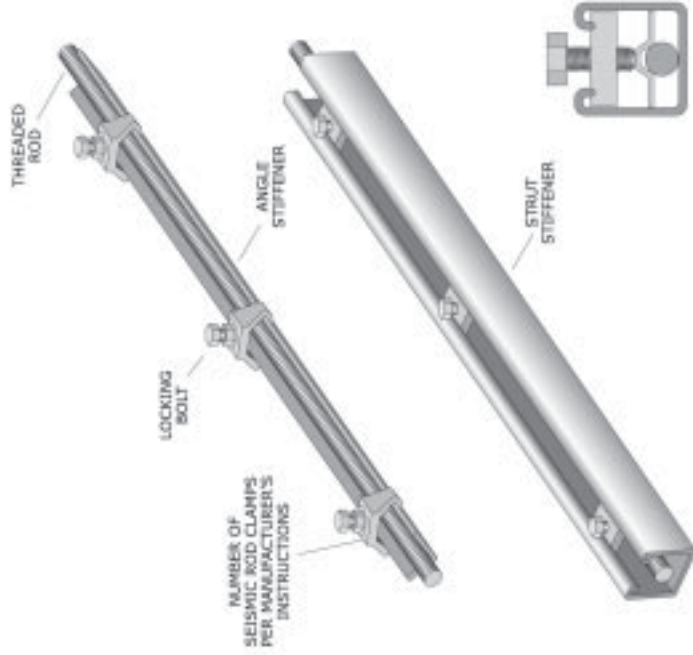

Figure 99: Rod stiffeners.

Step 3: Attach anchors to the building structure for cable attachment

Figure 100 (page 77) shows typical anchorage to different building construction. For instructions on installing anchors, see Anchors (page 104).

Step 4: Attach cable to the building structure

For cable assembly instructions, see Cables (page 133). For details on attaching cable to the building structure, see Figure 100 (page 77).

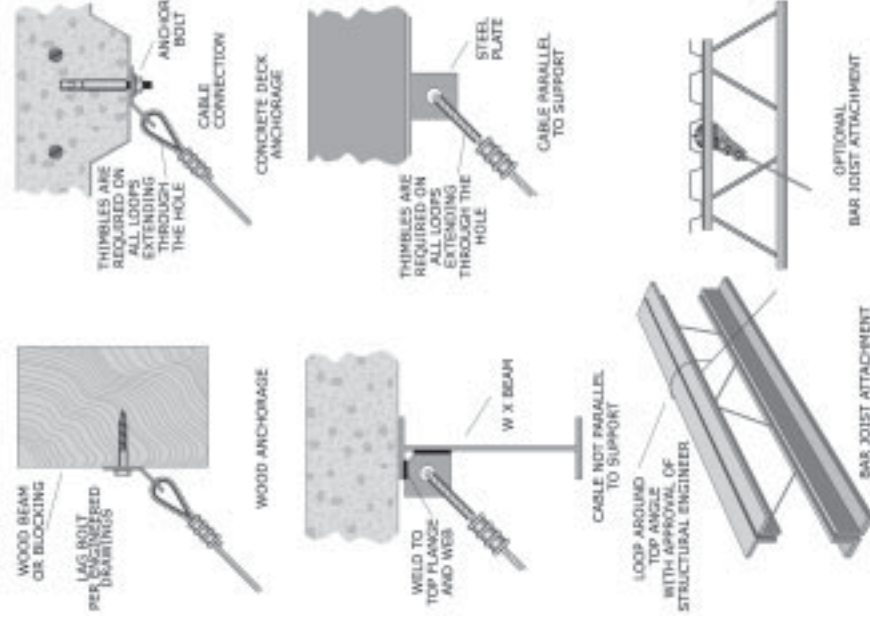

Figure 100: Attachments to the building structure.

For edge distances and spacing, see Lag Bolts (page 112).

Do not attach bracing to bottom of bar joist.

Step 5: Attach cables to equipment

For details on attaching cable to the equipment, see Figure 101 (page 78).

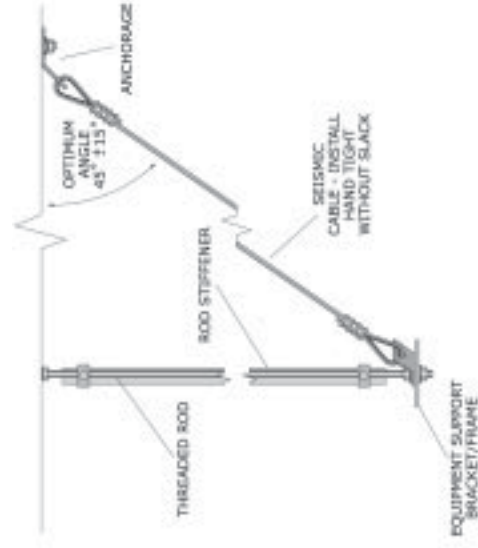

Figure 101: Attachment of cable to the equipment.

END OF ATTACHMENT.

Rigid connection to the building structure using angle/strut supports

Equipment may have pre-installed brackets for angle support attachments as shown below in Figure 102.

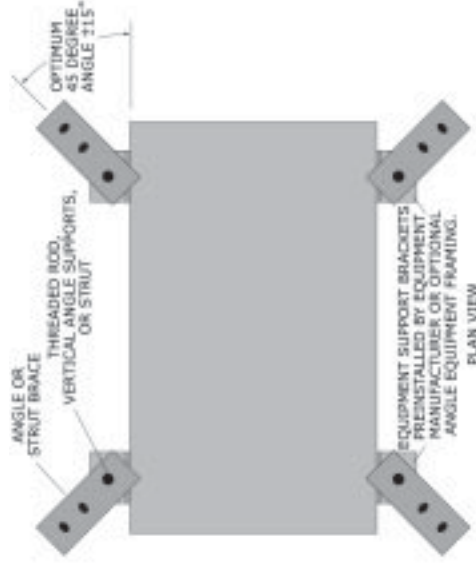

Figure 102: Rigid attachment of angles to the building structure.

Step 1: Attach the equipment to the building structure using threaded rods and anchors

Lay out all attachment points before anchoring. For building structure attachment details, see Figures 92 to 98 (pages 71 to 75). For instructions on installing anchors, see Anchors (page 104). Rod stiffeners may be required.

Step 2: Attach anchors to the building structure for angle or strut supports

For building structure attachment details, see Figures 92 to 98 (pages 71 to 75). For instructions on installing anchors, see Anchors (page 104).

Step 3: Attach angles or strut supports to the building structure

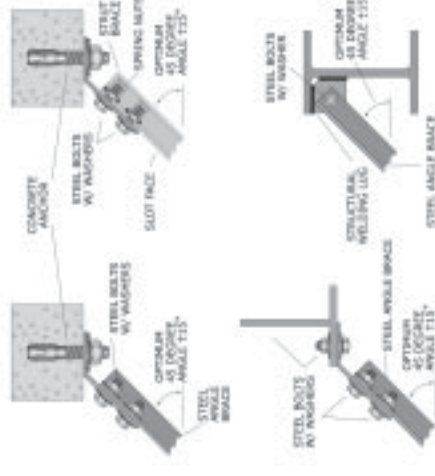

Figure 103: Attachment of angle or strut to the building structure.



Refer to approved construction documents for other attachments that may be permitted, similar to Figure 100 on page 77 (wood and bar joist).



Pre-approved manufacturer's/industry manuals may limit the maximum transverse and longitudinal angles to 45 degrees.



Attachment to bottom of beam if permitted by approved construction documents.

Step 4: Attach angle or strut to equipment

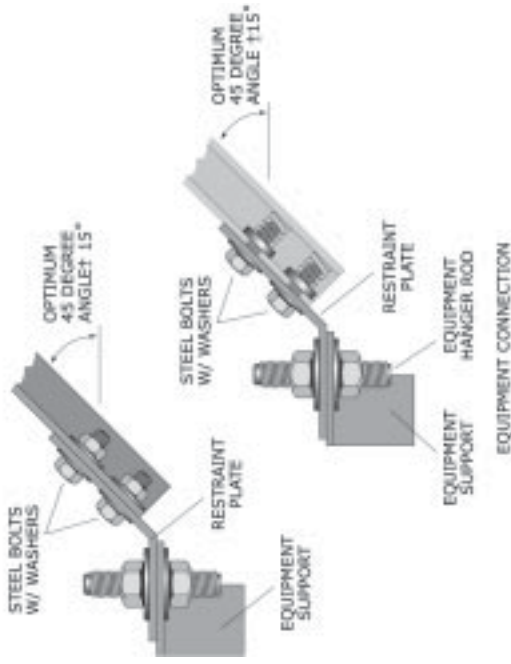

Figure 104: Attachment of angle or strut to the equipment.



Pre-approved manufacturer's/industry manuals may limit the maximum transverse and longitudinal angles to 45 degrees.

END OF ATTACHMENT.

Vibration-isolated connection to the building structure using a minimum of four threaded vertical rods and lateral restraints

Equipment may have pre-installed brackets for angle support attachments. See Figures 105 and 106 (below).

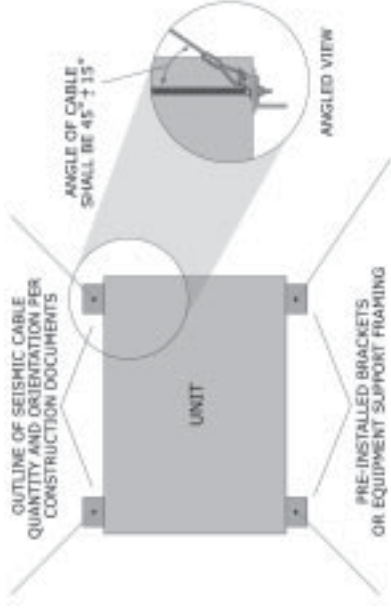

Figure 105: Plan view of vibration isolation suspended attachment to the building structure.

The side view (below) shows vibration isolators, rods (without rod stiffeners), and cables.

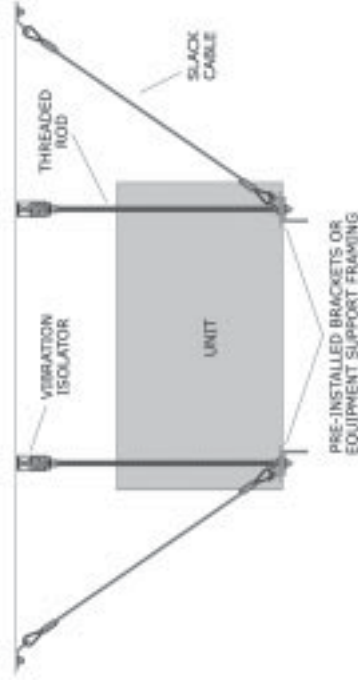

Figure 106: Side view of vibration isolation suspended attachment to the building structure.

Step 1: Attach equipment to the building structure using threaded rods, isolators and anchors

For the isolator detail, see Figure 107 (below). For building structure attachment details, see Figures 92 to 98 (pages 71 to 75).

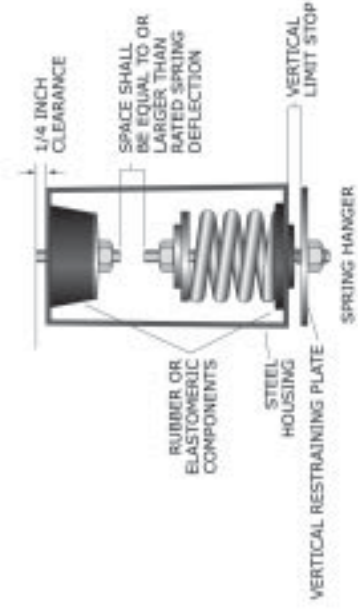

Figure 107: Isolator detail.

Step 2: Attach anchors and cable to the building structure

For details on attaching cable to the building structure, see Figure 100 (page 77). For instructions on installing anchors, see Anchors (page 104).

Step 3: Attach cables to equipment

For cable assembly instructions, see Cables (page 133). For details on attaching the vibration-isolated cable/rod assembly to the equipment, see Figure 108 (page 83).

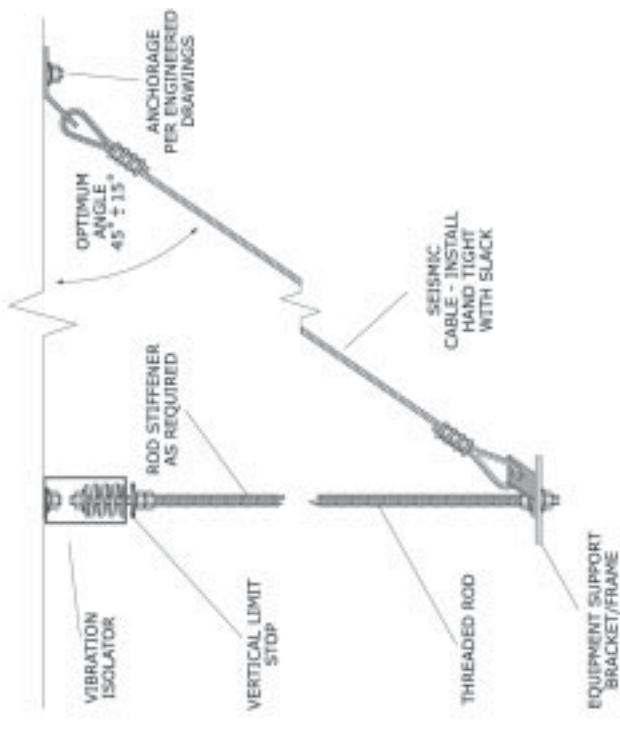

Figure 108: Attachment of cable/rod assembly to the equipment.

END OF ATTACHMENT.

Two point equipment attachment — bolted to the building structure

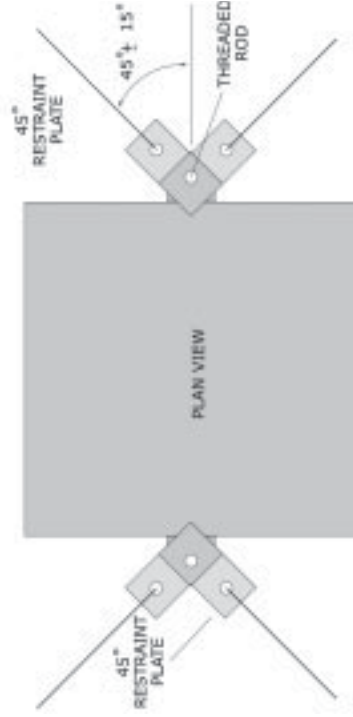
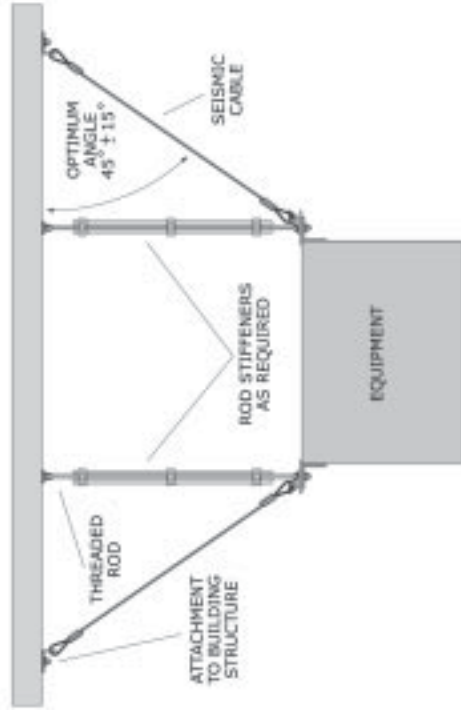

Figure 109: Two point equipment attachment.
Use this type of installation for unit heaters.

Step 1: Attach anchors and vertical rods to the building structure

Lay out all attachment points before anchoring. For building structure attachment details, see Figures 92 to 98 (page 71 to 75). Attach equipment to the vertical rods.



The attachment should be located just above the center of gravity to minimize swinging. It should be a rigid attachment with brackets to the equipment using double nuts and washers, especially if connected at the top as shown in Figure 109 (page 84).

Step 2: Attach rod stiffeners

For attachment details, refer to Figure 99 (page 76).

Step 3: Attach anchors to the building for cable attachment

Figure 100 (page 77) shows typical anchorage to different building construction. For instructions on installing anchors, see Anchors (page 104).

Step 4: Attach cable to the building structure

For cable assembly instructions, see Cables (page 133). For details on attaching cable to the building structure, see Figure 100 (page 77).

Step 5: Attach cables to equipment

The detail in Figure 109 (page 84) shows the attachment to the equipment.

END OF ATTACHMENT.

Chain mounted or bar support with swivel

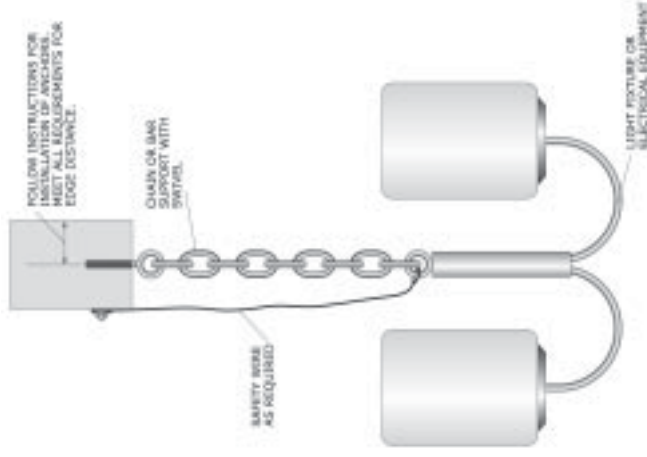

Figure 110: Chain mounted or bar support with swivel.

Step 1: Attach anchor to the building structure

Lay out all attachment points before anchoring. Follow all requirements for anchors. For instructions on installing anchors, see Anchors (page 104).

Step 2: Attach chain or bar to anchor

Attachment should allow the chain or bar to swing freely in all directions without binding.

 **Swinging motion should not be obstructed by other objects within the vicinity of the equipment supported by the chain.**

 **Design of anchorage must consider the sway of the light fixture during a seismic event.**

END OF ATTACHMENT.

Vibration-isolated/Floor-mounted Attachments

Vibration isolation uses several different springs or isolation pads to isolate equipment vibrations from the building structure. Vibration isolators can be open (see Figure 111, left), housed (see Figure 111, right), and restrained (see Figure 112, page 88).



NEVER USE HOUSED VIBRATION ISOLATORS FOR SEISMIC RESTRAINT APPLICATIONS. Housed isolators cannot resist uplift.

Snubbers (see Figure 113, page 88) are restraint devices to limit the movement of equipment that is isolated. Bumpers (see Figure 114, page 89) also limit the movement of equipment and are similar to snubbers.



NEVER USE SNUBBERS THAT ARE NOT SPECIFIED. Some snubbers only restrict movement in one direction.



NEVER USE OPEN VIBRATION ISOLATORS WITHOUT SNUBBERS OR BUMPER.

Bases are steel structures made from angles, channels, or I-beams.



Bases are required for mounting isolated equipment and rated for point loads. The equipment or isolator manufacturer may provide the bases.



Figure 111: Open (left) and housed (right) vibration isolators.



Figure 112: Four types of restrained vibration isolators.

 **Verify that the vibration isolator is properly aligned according to the manufacturer's clearances. If the vibration isolator shaft rubs against the snubber element, vibration isolation may not function or noise problems may occur.**



Figure 113: Two examples of snubbers.



Figure 114: Example of a bumper.



Figure 115: Vibration isolation pads.

Isolation pads may be placed under electrical equipment to reduce noise transmission to the building structure. Vibration isolation pads may be made of molded rubber, coated fiberglass, cork and various combinations thereof (see Figure 115 above for examples).



Figure 116: Rubber mounts.

Rubber mounts may be used to isolate equipment. See Figure 116 right, for rubber mounts with threaded steel inserts; left, for restrained rubber mounts.

The three ways of attaching vibration-isolated/floor-mounted equipment are on:

- Restrained vibration isolators (this page).
- Open isolators combined with snubbers (page 93).
- Elastomeric pads with isolated anchors (page 96).

Restrained vibration isolators

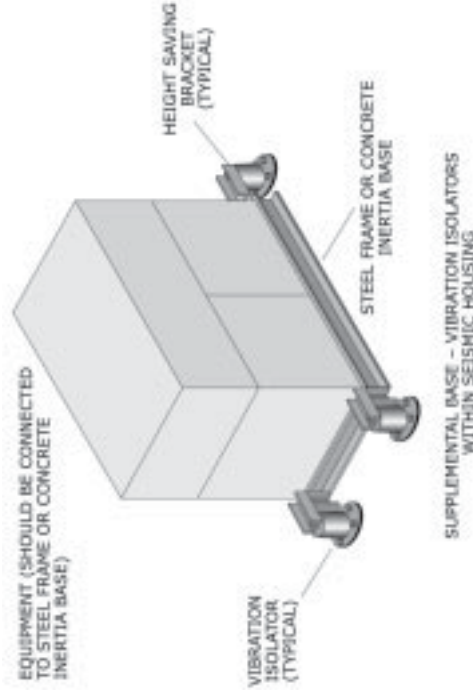

Figure 117: Typical installation of restrained vibration isolators.

More than four restrained vibration isolators may be required. See the manufacturer's instructions.

Step 1: Determine where to bolt the equipment

Accurately draw the bolt pattern on the floor or pad using one of the following methods:

- Set the equipment in place and mark the holes.
- Make a template.
- Use measurements and approved construction documents to lay out the bolt hole pattern.

Step 2: Install anchors

Drill and install post-installed anchors or pour concrete with embedded studs. For instructions on installing anchors, see Anchors (page 104).

Step 3: Set restrained isolators and bolt to anchors

Install restrained isolators to the building structure as shown in Figure 118 (below). Attach nuts to the anchor. Use bolts for shell-type anchors or internally threaded wedge or chemical anchors.



Torque bolts per manufacturer's recommendations.



BE CAREFUL NOT TO DAMAGE THE ANCHORS WHEN SETTING THE EQUIPMENT OR ISOLATORS.

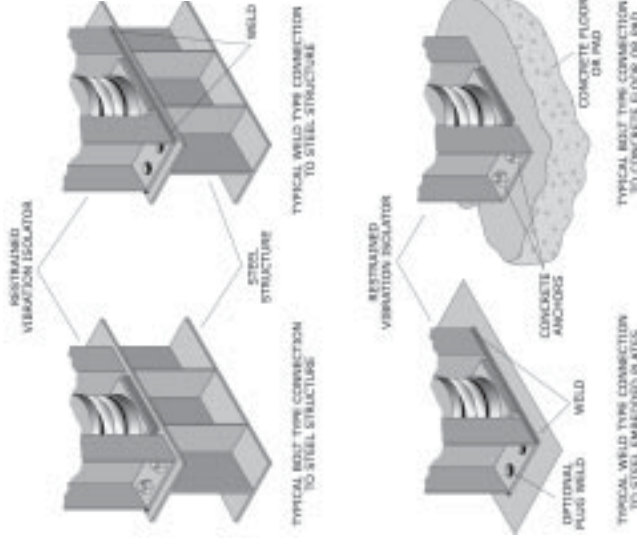

Figure 118: Attachment of restrained vibration isolators to the building structure.

Step 4: Move the equipment into place over the isolators

Use leveling nuts to level the equipment. Use attachment nuts to attach the base of the equipment to the isolator.

Figure 119 (below) shows typical ways to connect the equipment to the restrained isolators.

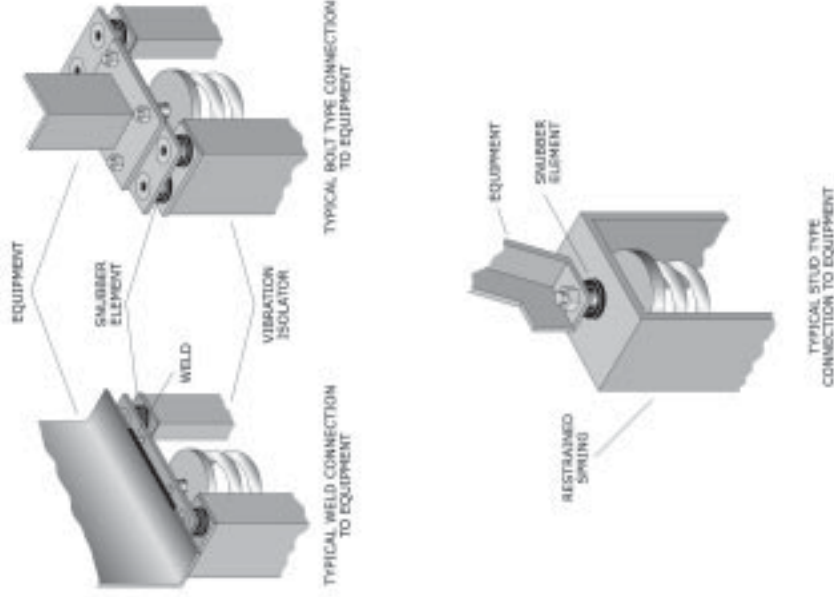

Figure 119: Attachment of equipment to restrained vibration isolators.

END OF ATTACHMENT.

Open isolators combined with snubbers

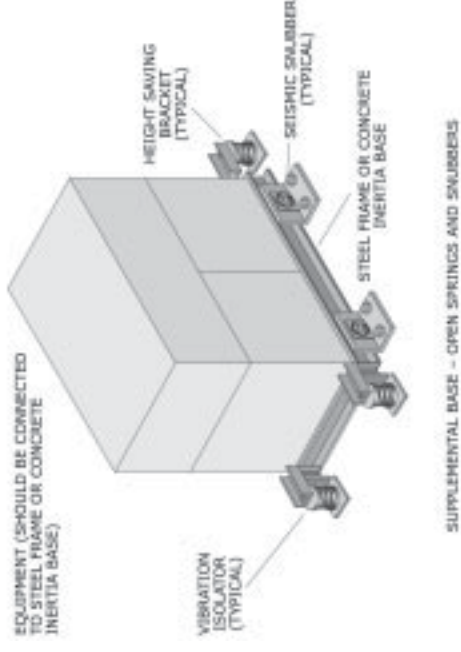

Figure 120: Typical installation of open isolators and snubbers.

Additional snubbers may be required. See the manufacturer's instructions.

Step 1: Determine where to bolt the equipment

Accurately draw the bolt pattern for the open isolator mounting plate on the floor or pad using one of the following methods:

- Set the equipment in place and mark the holes.
- Make a template.
- Use measurements and approved construction documents to lay out the bolt hole pattern.

Step 2: Install post-installed anchors for open isolators only (snubbers are covered in later steps)

Drill and install post-installed anchors for open isolators. For instructions on installing anchors, see Anchors (page 104).

Step 3: Attach open isolators to concrete floor or pad with anchors installed in Step 2

Set isolators, apply nuts and torque. Use bolts for shell-type anchors or internally threaded wedge or chemical anchors.



Torque bolts per manufacturer's recommendations.



BE CAREFUL NOT TO DAMAGE THE ANCHORS WHEN SETTING THE EQUIPMENT OR ISOLATORS.

Step 4: Set equipment on open isolators

Set equipment on isolators but do not level or torque attachment nuts.



Equipment structural frame must be point load capable at the open spring isolators.

Some installations require the base to be concrete-filled. See Figure 121 (below) for a typical concrete-filled installation.



Coordinate the attachment point locations of the equipment and snubbers *before* filling with concrete.

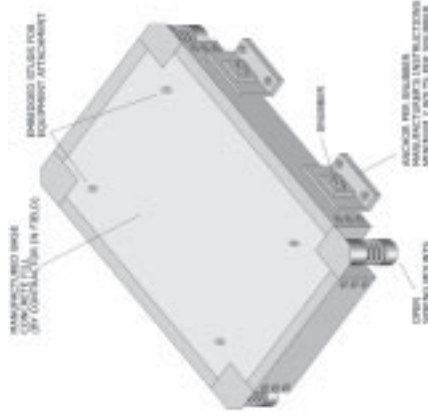

Figure 121: Concrete-filled inertia base.

Step 5: Determine where to attach snubber equipment assembly

A snubber has two assemblies: the snubber equipment assembly and the snubber base assembly.

Level the equipment. Final leveling will be required in later steps. Accurately draw the bolt pattern for the snubber equipment assembly mounting plate on the floor or pad and on the equipment.



All clearance requirements for aligning the snubber must be met. Shims may be provided.

Step 6: Attach snubber equipment assembly to equipment

Attach the snubber equipment assembly to the equipment by bolting it to embedded bolts in a concrete-filled base (see Figure 121, page 94), or by bolting or welding it to a steel base.

Step 7: Determine where to bolt snubber base

Accurately draw the bolt pattern for the snubber mounting plate on the floor or pad.

Step 8: Drill and install post-installed anchors

For instructions on installing anchors, see Anchors (page 104).

Step 9: Raise the equipment

Raise the equipment to allow the snubber base assembly to be placed over the anchors installed in Step 6.

Step 10: Lower the equipment



Level equipment and connect the two snubber assemblies as specified in the manufacturer's instructions. Verify that spacing requirements are met. Complete the final attachment to open isolators.



DO NOT INSTALL THE ISOLATORS OR SNUBBERS IN ANY CONFIGURATION OTHER THAN THAT SHOWN IN THE MANUFACTURER'S INSTRUCTIONS.

The equipment is now installed to resist earthquakes. Flexible piping, ductwork, and conduit connections must be used when connecting systems to isolated equipment.

END OF ATTACHMENT.

Elastomeric pads with isolated anchors

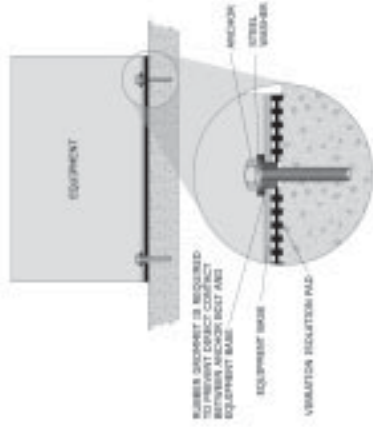

Figure 122: Elastomeric pads with isolated anchors.

Step 1: Determine where to bolt the equipment

Accurately draw the bolt pattern on the floor, concrete pad, or steel beams using one of the following methods:

- Set the equipment in place and mark the holes.
- Make a template.
- Use measurements and approved construction documents to lay out the bolt hole pattern.

It is preferred to use the holes provided by the manufacturer. Under supervisory approval, you may need to drill additional holes in the equipment assembly or building steel beams as shown on approved construction documents or the manufacturer's instructions.



USE CAUTION WHEN DRILLING INTO EQUIPMENT. Internal components can be damaged or the manufacturer's warranty may be voided.



DO NOT DRILL OVERSIZED HOLES. New holes cannot be oversized or oval in shape. Repair oversized holes as shown in Figure 76 (page 54), if necessary.

Step 2: Install anchors

If the equipment is to be anchored to concrete, drill and install post-installed anchors or pour concrete with cast-in-place studs (see Anchors, page 104).



If the equipment is to be bolted to steel, drill holes in the steel as shown on approved construction documents or the manufacturer's instructions.

Step 3: Move equipment into place



BE CAREFUL NOT TO DAMAGE THE ANCHORS WHEN SETTING THE EQUIPMENT.

Step 4: Attach nuts or weld equipment

Attach nuts to the anchor/bolt and torque, see Anchors (page 104) or weld equipment to steel beams or embedded plates, see Welding (page 128).

Raceways, conduits, and cable trays may now be connected.

END OF ATTACHMENT.

Wall-mounted Attachments

Use the instructions for mounting “Directly to the wall” (below) for equipment surface-mounted on the underside of a building structural slab or rated structural ceiling.

The three types of wall mounting are:

- Directly to the wall (this page).
- To additional structural steel shapes attached to the wall (page 100).
- Vibration-isolated off the wall (page 102).

Directly to the wall

Equipment should have pre-installed brackets that can support attachment to the building as shown in Figure 123 (below).

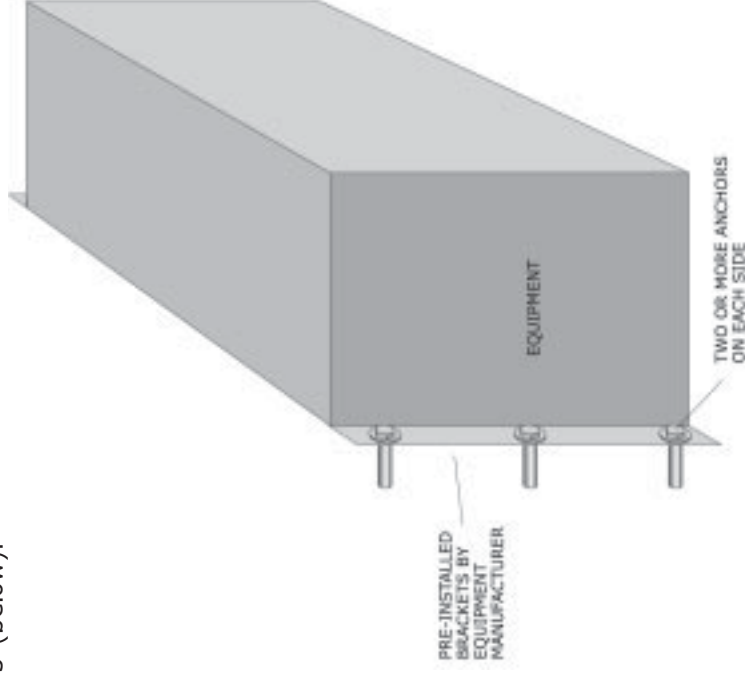

Figure 123: Direct attachment to a wall.

Step 1: Determine where to bolt the equipment

Accurately draw the bolt pattern on the wall using one of the following methods:

- Set the equipment in place and mark the holes.
- Make a template.
- Use measurements and approved construction documents to lay out the bolt hole pattern.

Drywall or masonry walls may require additional holes in equipment attachment brackets as shown on approved construction documents or in the equipment manufacturer’s instructions.



ONLY USE MOUNTING BRACKETS PROVIDED. DO NOT DRILL INTO THE EQUIPMENT HOUSING.



DO NOT DRILL OVERSIZED HOLES. New holes cannot be oversized or oval in shape. Repair oversized holes as shown in Figure 76 (page 54), if necessary.

Step 2: Install post-installed anchors

If anchoring to concrete, install post-installed anchors (see Anchors, page 104, or Masonry and Drywall Anchors, page 114).

Step 3: Move the equipment into place



BE CAREFUL NOT TO DAMAGE THE ANCHORS WHEN SETTING THE EQUIPMENT.

Step 4: Attach nuts



Attach nuts to the anchor or bolt and torque according to the manufacturer’s instructions.

Raceways, conduits, and cable trays may now be connected.

END OF ATTACHMENT.

To additional structural steel shapes attached to the wall

Equipment attaches to the wall with additional structural steel shapes and bolts. Shapes may be welded. These steel shapes are attached to the building using concrete, masonry, or drywall anchors.

Figure 124 (below) shows how angles and struts can be used for attachment to a wall. Angles and struts must accommodate wall construction attachment points and obstructions. Figure 157 (page 142) shows the direct attachment of a strut assembly.

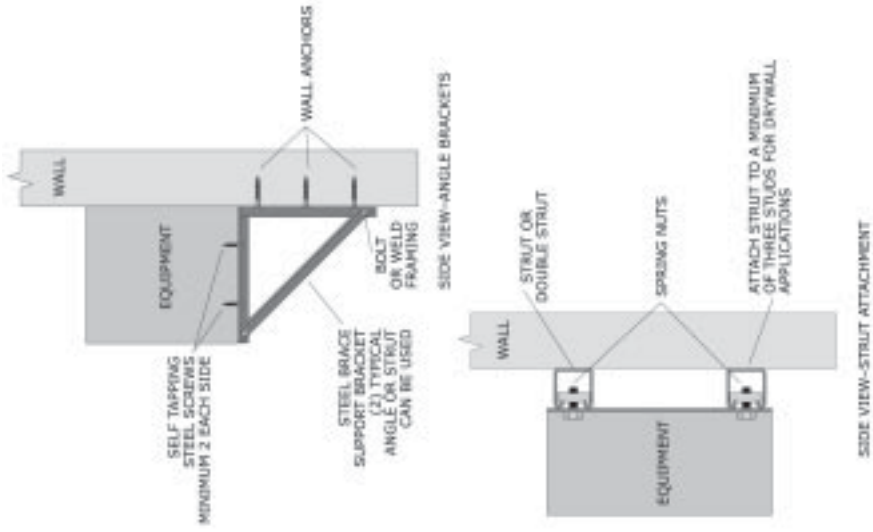

Figure 124: Angle or strut support.

Electric water heaters may be attached to the wall with a simple strap arrangement, as shown in Figure 125 (below).

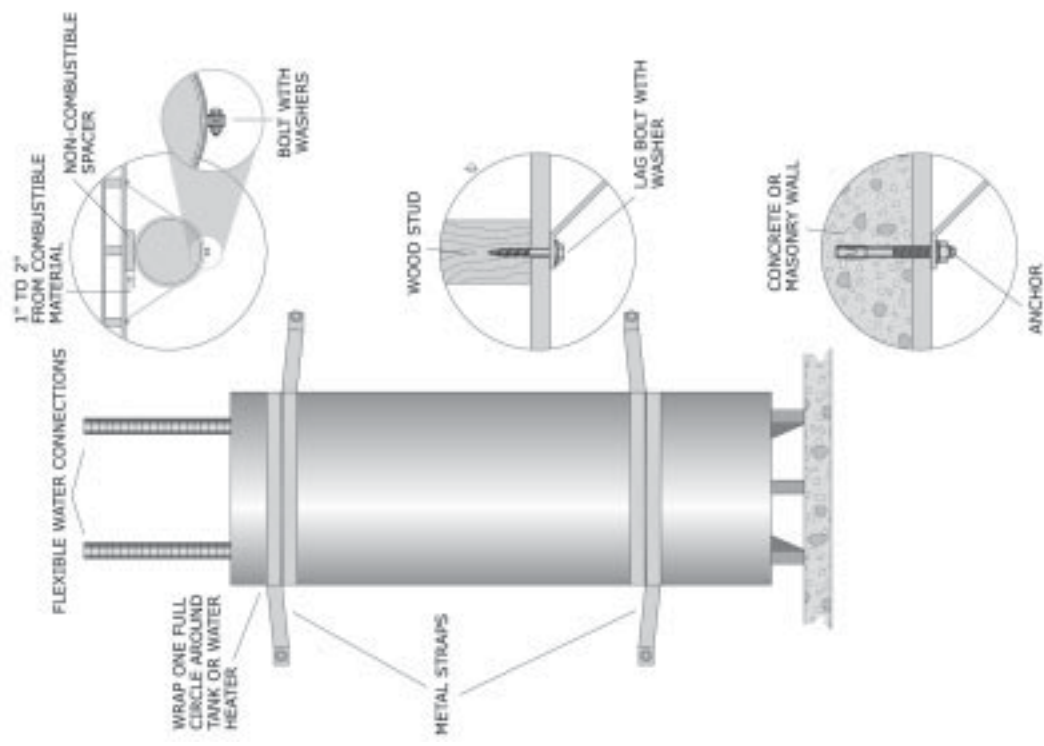

Figure 125: Electric water heater attachment.

Step 1: Determine the anchor locations

Find studs in drywall. Use measurements and construction drawings to lay out the bolt hole pattern and mark the anchor locations.

Step 2: Install anchors

If anchoring to concrete, install post-installed anchors (see Anchors, page 104, or Masonry and Drywall Anchors, page 114).

Step 3: Move equipment into place and bolt to frame

 **It is preferred to use the holes provided by the manufacturer. Under supervisory approval, you may need to drill additional holes in the equipment assembly or building steel beams as shown on approved construction documents or the manufacturer’s instructions.**

 **USE CAUTION WHEN DRILLING INTO EQUIPMENT. Internal components can be damaged or the manufacturer’s warranty may be voided.**

 **DO NOT DRILL OVERSIZED HOLES. New holes cannot be oversized or oval in shape. Repair oversized holes as shown in Figure 76 (page 54), if necessary.**

Raceways, conduits, and cable trays may now be connected.

END OF ATTACHMENT.

Vibration-isolated off the wall

Equipment attaches to the wall with additional structural steel shapes, threaded rods and vibration isolators. Shapes may be welded. These steel shapes are attached to the building using concrete, masonry, or drywall anchors.

Figure 126 (page 103) shows how rods, angles and struts can be used to isolate equipment attached to a wall. Angles and struts accommodate wall construction attachment points.

Vibration-isolation of equipment reduces the transmission of equipment noise and vibration into the building structure. See Figure 107 (page 82) for isolator detail.

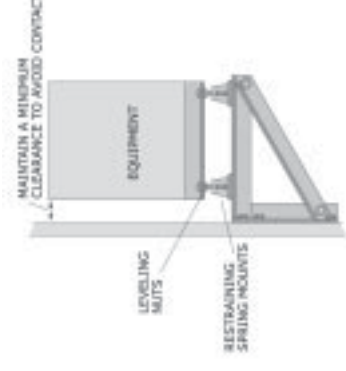

Figure 126: Wall-mounted, vibration-isolated equipment.

Step 1: Assemble wall frame with isolators

Accurately draw the bolt pattern on the wall using one of the following methods:

- Set the frame in place and mark the holes.
- Make a template.
- Use measurements and approved construction documents to lay out the bolt hole pattern.

Step 2: Install anchors

If anchoring to concrete, install post-installed anchors (see Anchors, page 104, or Masonry and Drywall Anchors, page 114).

Step 3: Attach isolators, rod, and hang equipment

Attach the isolators to the framing.

Raceways, conduits, and cable trays may now be connected.

END OF ATTACHMENT.

ANCHORS

General Anchors



IMPORTANT: Installation methods depend on the type of anchor and the particular application. Always follow the anchor manufacturer's installation instructions.

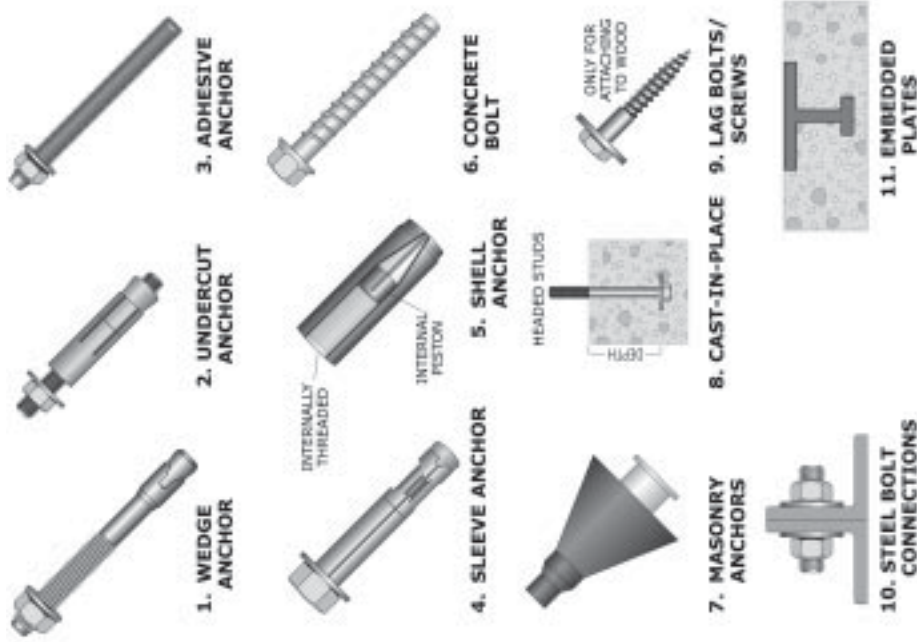

Figure 127: Types of anchors.



Some anchors shall not be used with vibratory loads.

Step 1: Determine the type of anchor

Using Figure 127 (page 104), identify the anchor recommended for your application. Anchors 1-6 are post-installed anchors and instructions for installing them begin on this page. Anchors 7-11 are specialty anchors and instructions are shown on pages 112 to 129.

The various steps for installing anchors into concrete, brick, and concrete block anchors are shown below.

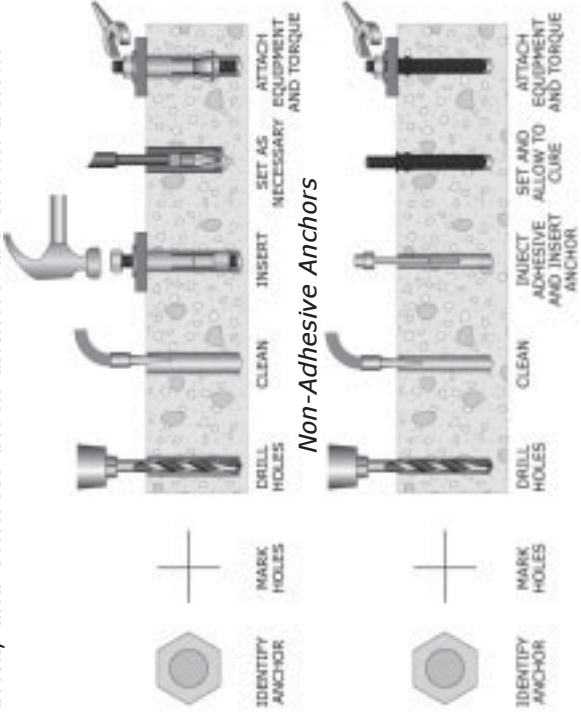

Adhesive Anchors

Figure 128: Summary of installation steps.



Approved construction documents may require special inspection to torque anchors or for proof load using hydraulic rams.

Step 2: Determine where to drill the hole

To determine anchor locations for the equipment you are installing, follow the instructions for the Attachment Type you are using (pages 51 to 103). Coordinate the equipment connections and hole locations with the location of any steel reinforcements or tendons.

Determine the depth and location of any steel reinforcement or tendons *before* drilling. This may require relocating equipment slightly to avoid the reinforcement.



FOR POST-TENSIONED (PRE-STRESSED) BUILDINGS, LOCATE THE TENDONS BEFORE DRILLING. EXTREME DAMAGE MAY OCCUR IF A TENDON IS NICKED OR CUT.

When using electronic locating devices to find reinforcement and tendons, make sure you know the limitations of the device. Calibrate and test with a known standard or location to confirm accuracy. Check the area of concern in two directions. Inform the contractor performing the work of the precision of the test unit and record the results. For example: *agreed upon mark +/- 1/4" location vertical, horizontal, and depth +/- 1/2"*.

Coordinate the location of anchors with the edge of the concrete, construction joints, and other anchors.



Do not install the anchor too close to the edge of the concrete base. Typically the anchor's distance from the edge is 1 1/2 times the embedment depth.



Do not install an anchor too close to another anchor. Typically the minimum spacing between anchors is two times the anchor's embedment depth.

Step 3: Drill the hole



Drill the right-sized hole for the anchors. Use the appropriate ANSI-rated drill bit for the application.



Do not drill holes into concrete at an angle.

For wedge, undercut and sleeve anchors, drill the hole deeper than the required embedment depth.



The required hole depth may be different from the embedment depth. See Figure 129 (page 107).

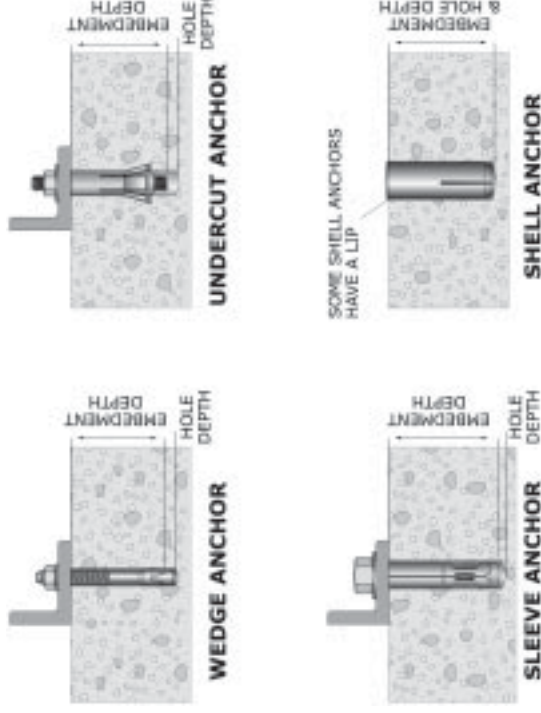

Figure 129: Embedment depth and hole depth of four anchor types.

The depth of the concrete base must be at least one inch greater than the hole you are drilling.



Some undercut anchors require an even deeper concrete base.



If you strike steel reinforcement when drilling, you must have the damage inspected. As directed, fill the hole with approved grout and select a new location according to minimum spacing requirements. Drill a new hole (see below).

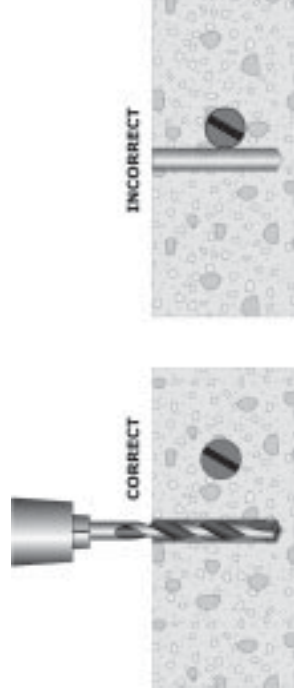

Figure 130: Drilling into concrete with rebar.

Step 4: Clean out the hole

Drilled holes must be cleaned before you can insert the anchor. Use clean, dry compressed air to blow out dust and debris. The type of anchor or application also may require you to use a brush.



See the anchor manufacturer's instructions for cleaning the hole.



CLEANING IS IMPORTANT: a "dirty" hole can significantly reduce an anchor's performance.

Step 5: Insert the anchor

If you are installing any anchor *other than* an adhesive anchor, drive the anchor into the hole with a hammer or use a wrench rotor hammer for concrete bolts.



IMPORTANT: DO NOT DAMAGE THE THREADS DURING INSTALLATION. DO NOT FORCE THE ANCHOR. If you use a larger hammer than recommended by the manufacturer, you may damage the anchor.

If you are installing an adhesive anchor, insert the capsule or inject non-capsule adhesive into the hole. Slowly rotate the anchor into place as shown below.

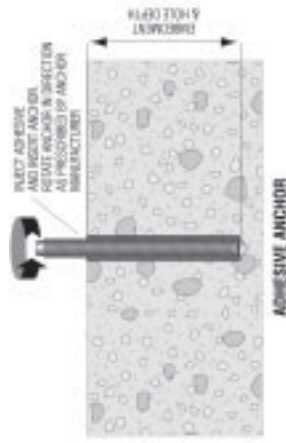

Figure 131: Adhesive anchor installation.

If you have installed a wedge or sleeve anchor, go to Step 7 (page 110).

Step 6: Setting adhesive, shell and undercut anchors ONLY



Adhesive Anchor: Allow enough time for the adhesive to fully cure. The curing process may take a long time. See the manufacturer's instructions.



Shell Anchor: Drive the prescribed setting tool into the anchor until the setting tool shoulder meets the edge of the anchor, as shown below. See the manufacturer's instructions.

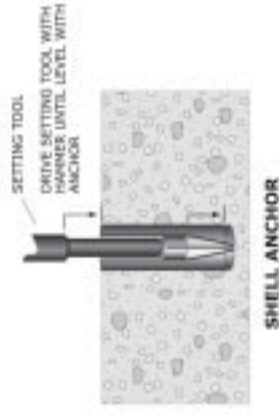

Figure 132: Set shell anchors.



Undercut Anchor: Use special tools provided by the anchor manufacturer to set the anchor, as shown below. See the manufacturer's instructions.

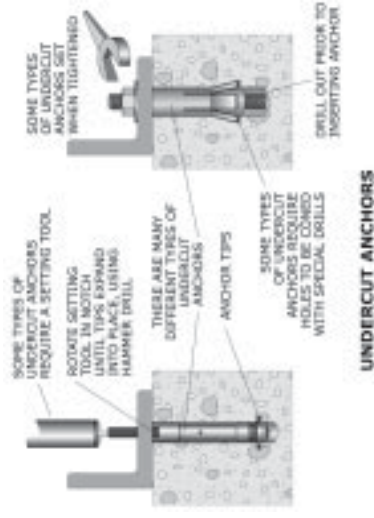

Figure 133: Set undercut anchors.

Step 7: Set the equipment and tighten the anchors

Set the equipment in place. Check for gaps. Gaps under the equipment must not be greater than 1/8" as shown below. If the gap is greater than 1/8", dry pack the gap with grout and repeat this step.

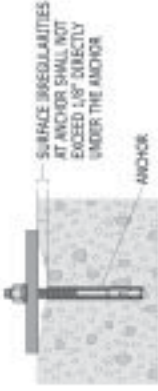

Figure 134: Acceptable gap for grouted plate.

For anchor bolts larger than 3/8", the equipment housing should be reinforced using a structural angle bracket as shown in Figure 135 (below).

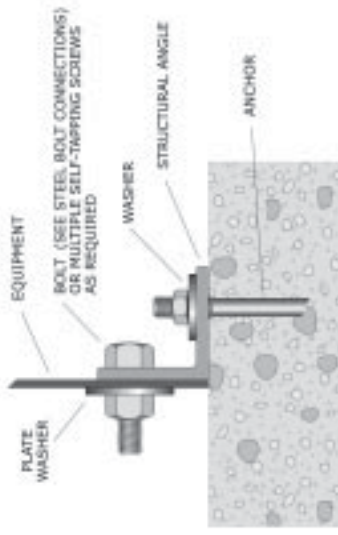

Figure 135: Installing a reinforcing angle bracket to equipment.



Tighten the anchor bolt to the correct torque setting in the manufacturer's instructions or approved construction documents. Use a calibrated torque wrench.

END OF DETAIL.

Cast-in-place Anchors

Cast-in-place anchors are embedded in the concrete when the floors or walls are poured. Bolts are firmly held in place while the concrete is poured to maintain proper alignment and position. The size and location of the anchors can be determined from approved construction documents.

Step 1: Move the equipment into place

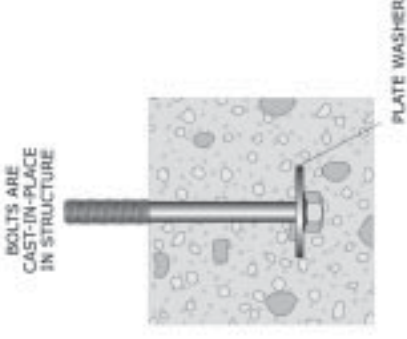

Figure 136: Bolting equipment to cast-in-place anchors.

Step 2: Secure equipment

Once the equipment is in place, apply washers and nuts and then tighten.



Tighten the anchor bolt to the correct torque setting in the manufacturer's instructions or approved construction documents. Use a calibrated torque wrench or turn-of-nut method (see Table 14, page 124).

END OF DETAIL.

Lag Bolts

Lag bolts are used to attach equipment or steel shapes to wood structures. The size and location of the anchors can be determined from construction drawings (see Figure 137 below).

- The edge distance for the non-loaded side is 1½ times the bolt diameter.
- The edge distance for the loaded side is 4 times the bolt diameter.
- The spacing between bolts is 4 times the bolt diameter.
- The end distance is 7 times the bolt diameter.

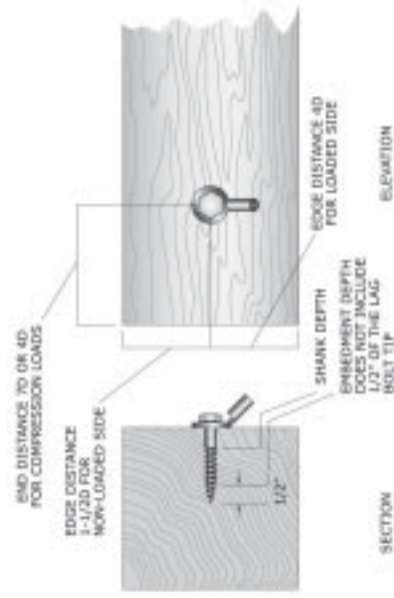

Figure 137: Spacing requirements for wood lag bolts.

Figure 137 is allowed for cable attachment. If a strut is attached to wood, both edge distances are considered loaded and require 4 times the bolt diameter.



Do not anchor to the end grain.

Step 1: Mark the location of the lag bolts

Lead holes and clearance holes are not required for lag bolts that are 3/8" or smaller. If the lag bolt is smaller than 3/8", go to Step 4.

Step 2: Drill a clearance hole

Drill a hole with a drill bit the same size as the shank of the bolt. The depth of the hole is the same as the length of the unthreaded shank that will extend into the wood (see Figure 137, page 112).

Step 3: Drill a lead hole

Drill a hole with a drill bit that is 60% to 70% of the diameter of the shank of the bolt. The depth of the hole is the same as the embedment depth of the bolt (see Figure 137, page 112).

Step 4: Move the equipment or steel shape into place

Step 5: Install the lag bolt with a wrench

You may use soap or other lubricant on the lag bolt.



DO NOT USE A HAMMER TO INSTALL LAG BOLTS.

Step 6: Tighten the bolt

Hand-adjust the lag bolt until there is firm contact between the lag bolt and connected metal components. Hand tools may be used to bring the lag bolt and metal components into contact. Following contact, tighten nut as shown in Table 14 (page 124).

END OF DETAIL.

Masonry and Drywall Anchors

Step 1: Determine the type of anchor



Figure 138: Types of masonry and drywall anchors.

Step 2: Determine where to drill the hole

Anchors shown in Figure 138 (page 114) must be installed in specific areas of hollow block and in-filled block. See Figure 139 (below) for approved anchor hole locations when using any of the concrete block anchors shown in Figure 138 (page 114).

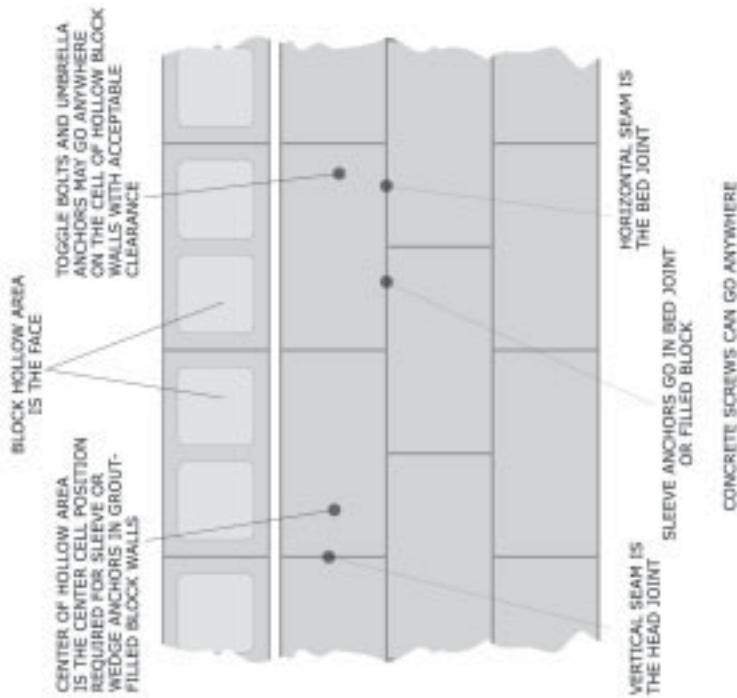

Figure 139: Block wall locations.

The location of the anchors should be coordinated with the block webs, or centered in the cell face, and properly spaced from other anchors.



DO NOT POSITION THE HOLES IN THE HEAD JOINT. Carefully note the location of anchors in the face location, centered face location, and bed joint as they apply to different anchors.

 **When installing through-bolts: avoid webs in block walls, reinforcements in grout-filled walls, and studs in drywall.**

 **When installing lag bolts and sheet metal screws in drywall: install in a wood or metal stud as appropriate.**

 **Determine the depth and location of any steel reinforcement in grout-filled block walls or brick before drilling. This may require relocating equipment slightly to miss reinforcement.**

When using electronic locating devices to find reinforcements and tendons, make sure you know the limitations of the device. Calibrate and test with a known standard or location to confirm accuracy. Check the area of concern in two directions. Inform the contractor performing the work of the precision of the test unit and record the results. For example: *agreed upon mark +/- 1/4" location vertical, horizontal, and depth +/- 1/2".*

Step 3: Drill the hole

 **Drill the right-sized hole for the anchors. Use the appropriate ANSI-rated drill bit for the application.**

Use masonry drill bits for brick and block.

 **DO NOT CUT STEEL REINFORCEMENT WHEN DRILLING HOLES.**

 **If you strike steel reinforcement when drilling, you must have the damage inspected. As directed, fill the hole with approved grout and select a new location according to minimum spacing requirements. Drill a new hole (see Figure 130, page 107).**

 **Holes for concrete screws are smaller than screw size. See the manufacturer's instructions for specific requirements.**

Step 4: Clean out the hole

Drilled holes must be cleaned before you can insert the anchor. Use clean, dry compressed air to blow out dust and debris. The type of anchor or application also may require you to use a brush.



See the anchor manufacturer's instructions for cleaning the hole.



CLEANING IS IMPORTANT: a "dirty" hole can significantly reduce an anchor's performance.

Step 5: Insert the anchor

The following anchors use different insertion methods.

- Adhesive screen anchor in a brick wall or hollow block wall (this page).
- Adhesive anchor in a hollow block wall (page 118).
- Concrete screw (page 119).
- Toggle bolt (page 119).
- Concrete anchor (sleeve anchor or wedge anchor) (page 120).
- Drywall anchor (lag bolts and sheet metal screws) (page 120).

Adhesive screen anchor in a brick wall or hollow block wall



See the anchor manufacturer's instructions before connecting the anchor to a brick or hollow block wall.

A screen insert is shown in Figure 140 (page 118). Insert the screen in the wall. Inject the adhesive. Slowly insert the anchor with a twisting motion.



Screens may be filled with adhesive before inserting the screen into the hole.

For details on installing adhesive anchors in a brick wall, see Figure 141 (page 118). Similar installation applies to hollow block walls. Adjust the anchor by hand while the adhesive sets.



DO NOT TOUCH THE ANCHOR WHILE THE ADHESIVE IS CURING.



Figure 140: Brick/block wall insert.

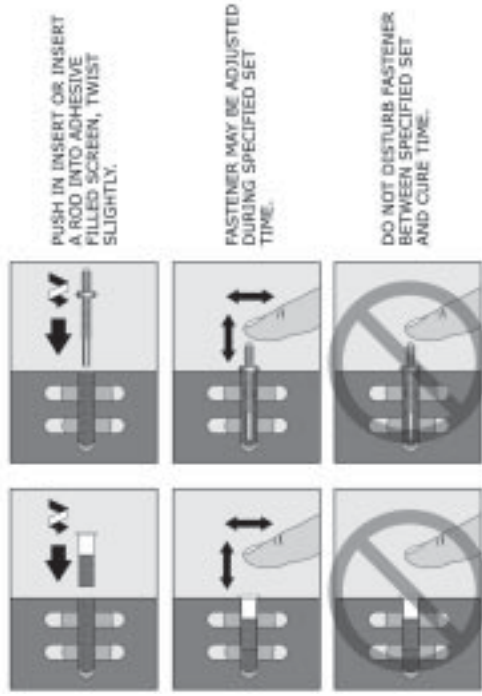

Figure 141: Brick wall adhesive anchor.

Adhesive anchor in a hollow block wall



See the anchor manufacturer’s instructions before connecting the anchor to a hollow block wall.

Push an umbrella anchor into the hole until the umbrella unfolds in the block cavity. Inject adhesive into the umbrella. Slowly insert stud or fastener with a twisting motion.



DO NOT LEAK ADHESIVE ON THE THREADED PORTION OR CLEAN WITH SOLVENT. The threaded area must be free of debris to attach to a threaded rod or steel bolt.

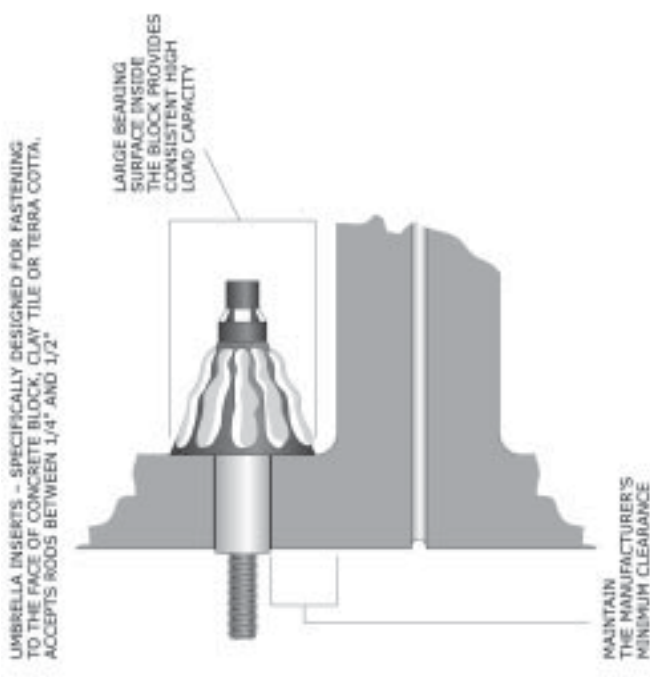

Figure 142: Umbrella anchor in a hollow block wall.

Concrete screw

Drill bits may be specifically sized for each manufacturer, and typically are smaller in diameter than the nominal or fractional diameter of a screw. Install a concrete screw with a rotary drill and bolt the head attachment.

Toggle bolt

Hold the toggle flat alongside the plastic straps and slide the channel through the hole. Slide the holding ring toward the wall until the channel is flush with the wall. Cut off the straps at the holding ring. Insert the bolt with a rotary drill over the bracket or equipment mounting (see Figure 143 on page 120).

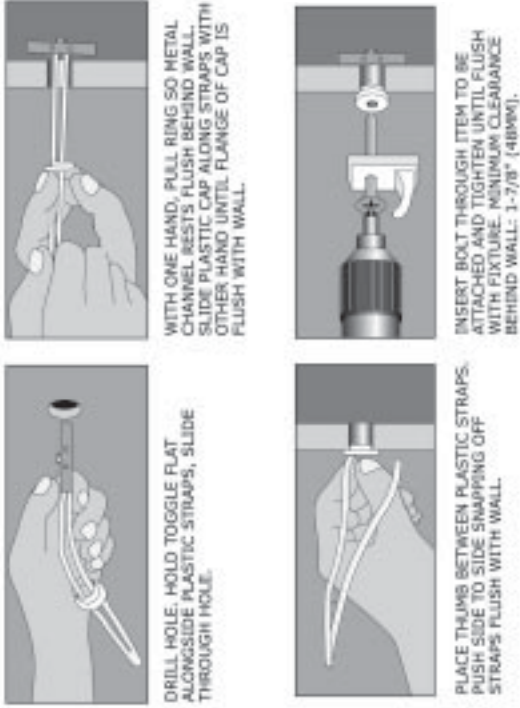

Figure 143: Toggle bolt installation.



DO NOT OVER-TIGHTEN.

Concrete anchor (sleeve anchor or wedge anchor)

Use a hammer to drive the anchor in the hole.



DO NOT FORCE THE ANCHOR. If you use a hammer larger than recommended, you may damage the anchor.

To determine the embedment depth of post-installed anchors, see Figure 129 (page 107).

Drywall anchor (lag bolts and sheet metal screws)

Use a rotary drill to insert the anchor.



DO NOT OVER-TIGHTEN.

Step 6: Set the anchor (adhesive only)

Allow enough time for the adhesive to harden and adhere to the concrete. *This may take several hours.*

Step 7: Set the equipment and tighten the anchors



Tighten the anchor bolt to the proper torque setting as shown in the anchor manufacturer's instructions or approved construction documents.

In-filled block walls may have gaps in the grout fill or the grout may slightly crack, requiring anchors to be installed in the center of the cell.



If the grout cracks severely, or if you miss a grouted block, the anchor will not tighten and will pull out. If it pulls out, move the anchor to a new centered cell location.

END OF DETAIL.

Power-Actuated Anchors

Step 1: Determine type of anchor



Figure 144: Two types of power-actuated anchors.



Authorities having jurisdiction may require a license to use power-actuated anchors.



Refer to the Anchor Selection Guide (page 151) for additional information.

Step 2: Determine where to place the fastener



Follow the manufacturer's recommendations for minimum slab thickness and best location.

Step 3: Install anchor

Using tools provided by the anchor manufacturer, install the anchor at the desired location. Follow all the manufacturer's instructions. Also see Power-Actuated information in the Anchor Selection Guide (page 151).

For threaded rods, follow Step 4.

When using drive pins, install the pin with the strap or wire to complete the installation.

Step 4: Set equipment and tighten

Tighten the anchor nuts over equipment brackets on the threaded rods.

END OF DETAIL.

Steel Bolt Connections

The three ways to attach bolted connections are:

- Connecting the base of the equipment to an angle bolted to a concrete floor (this page).
- Bolting two structural steel shapes together (page 125).
- Bolting a threaded rod to steel shapes or strut (page 126).

Connecting the base of the equipment to an angle bolted to a concrete floor

Step 1: Preparation



Determine the bolt size or sheet metal screw and material requirements from approved construction documents or the manufacturer's instructions.

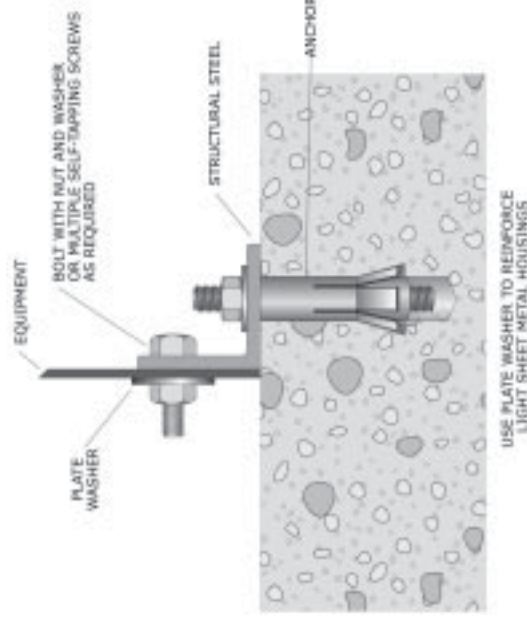

Figure 145: Bolting equipment to an angle.

Step 2: Locate attachment holes



It is preferred to use the holes provided by the manufacturer. Under supervisory approval, you may need to drill additional holes in the equipment assembly or building steel beams as shown on approved construction documents or the manufacturer's instructions.



USE CAUTION WHEN DRILLING INTO EQUIPMENT. Internal components can be damaged or the manufacturer's warranty may be voided.



DO NOT DRILL OVERSIZED HOLES. New holes cannot be oversized or oval in shape. Repair oversized holes as shown in Figure 76 (page 54), if necessary.

Step 3: Install bolts, washers, and nuts

Once the equipment is in place, apply washers and nuts and then tighten.



Tighten the anchor bolt to the correct torque setting shown in the manufacturer's instructions or approved construction documents.

For turn-of-nut tightening, hand-adjust the bolt until there is firm contact between the bolt and the connected metal components. Hand tools may be used to bring the bolt and metal components into contact. Following contact, tighten the nut as shown below.

<i>Length of Bolt</i>	<i>Additional Tightening</i>
Up to and including 4 diameters	1/3 turn
Over 4 diameters and not more than 8 diameters	1/2 turn
Over 8 diameters and not more than 12 diameters	5/6 turn

Table 14: Turn-of-nut, hand-adjusted tightening.

Bolting two structural steel shapes together

Step 1: Preparation



Determine the bolt size and material requirements from approved construction documents or the manufacturer's instructions.



Figure 146: Bolting structural shapes.

Step 2: Locate holes



It is preferred to use the holes provided by the manufacturer. Under supervisory approval, you may need to drill additional holes in the equipment assembly or building steel beams as shown on approved construction documents or the manufacturer's instructions.



USE CAUTION WHEN DRILLING INTO EQUIPMENT. Internal components can be damaged or the manufacturer's warranty may be voided.



DO NOT DRILL OVERSIZED HOLES. New holes cannot be oversized or oval in shape. Repair oversized holes as shown in Figure 76 (page 54), if necessary.

Step 3: Install bolts, washers, and nuts

Apply washers and nuts, then tighten.



Tighten the anchor bolt to the correct torque setting shown in the manufacturer's instructions or approved construction documents. Use a calibrated torque wrench or turn-of-nut method (see Table 14, page 124).

Bolting a threaded rod to steel shapes or strut

A threaded rod is used with suspended equipment. This section includes attachment to the equipment and attachment at the top (see Suspended Attachments, page 71).

Step 1: Preparation



Determine the threaded rod size from approved construction documents or the manufacturer's instructions.

The three different ways to attach the top connection of a threaded rod are shown in Figure 147 (below).

Step 2: Attach the top connection of the threaded rod

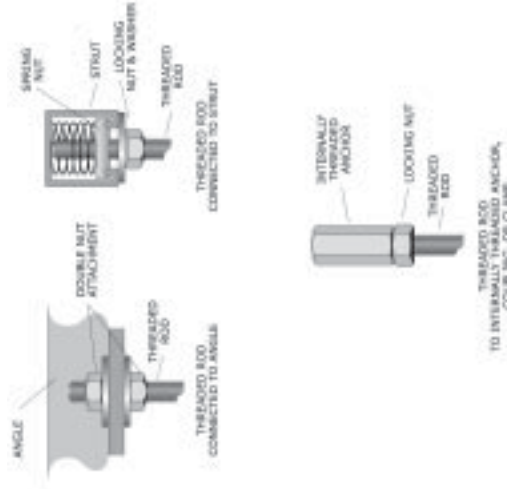

Figure 147: Attaching the top connection of the threaded rod.

Apply washers and nuts, then tighten.



Tighten the anchor bolt to the correct torque setting shown in the manufacturer's instructions or approved construction documents. Use a calibrated torque wrench or turn-of-nut method (see Table 14, page 124).

Step 3: Attach threaded rods to equipment brackets

Equipment without attachment brackets require additional steel shapes for connections to the building structure and/or roof.

Once the equipment is in place, apply washers and nuts, then tighten.



Tighten the anchor bolt to the correct torque setting shown in the manufacturer's instructions or approved construction documents. Use a calibrated torque wrench or turn-of-nut method (see Table 14, page 124).

END OF DETAIL.

Welding



Before welding, refer to approved construction documents and specifications, seismic restraint submittals, and manufacturer's instructions.

Attaching equipment to embedded plates: Plates are embedded in the concrete during the floor or wall pour. Plates are firmly held in place while the concrete is poured to maintain proper alignment and position. The size and location of the plate can be determined from approved construction documents. See Figure 148 (below) for weld locations.

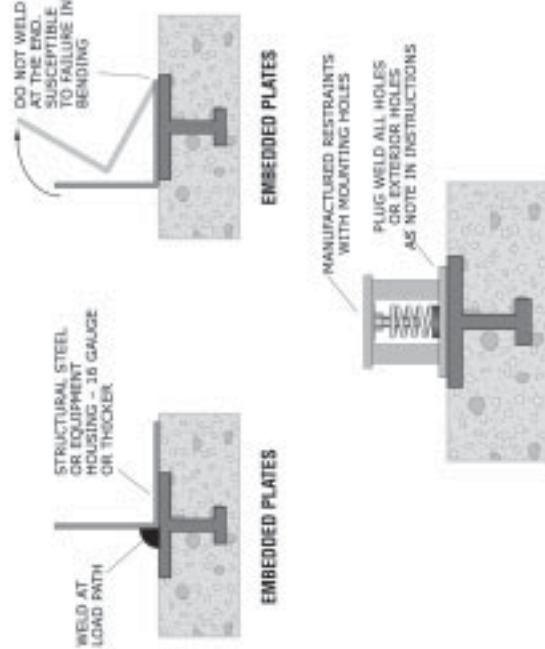

Figure 148: Welding to embedded plates.

Attaching structural shapes and plates: Shapes and plates are welded to provide equipment attachment. All weld base material must be thick enough for the weld size specified.

Step 1: Determine the weld material, shape, and dimensions for each piece

Step 2: Fit the material to ensure proper weld joint preparation

Step 3: Clean the surfaces

Surfaces must be dry and free of galvanized coating, hot-dipped or rust inhibitor, paint, scale, rust, oil, grease, water, and other foreign material for a minimum of one inch from the estimated toe of the weld.

Step 4: Weld the materials

The weld must be as prescribed in the welding procedure specifications (WPS).

WPS for shop and field pre-qualified weld joints and weld joints qualified by test must be prepared for review and approval before fabrication. All welding procedure items such as base metals, welding processes, filler metals and joint details that meet the requirements of AWS D1.1 will be considered prequalified. Any change or substitution beyond the range or tolerance or requirements for pre-qualification will be qualified by test per AWS D1.1.



DO NOT WELD OVER PAINT. You may paint after welding has cooled to room temperature.

Step 5: Inspect the weld

Make sure the surface is free of slag, dirt, grease, oil, scale, or other contaminants.

Welds cannot have cracks. Adjacent layers of weld metal and base metal must be thoroughly fused together.

All craters must be filled to the full cross-section except outside the effective weld length.

Underrun must not exceed 1/16". Undercut must not exceed 1/16" for any 2" per 12" weld or 1/32" for the entire weld.

Surfaces must be free of coarse ripples, grooves, abrupt ridges, and valleys. The faces of fillet welds must be flat or slightly convex.

END OF DETAIL.

Anchor Sizes for Equipment Weighing Less than 400 Pounds

Rigid floor-mounted equipment

Bolt equipment to a concrete floor or weld to a steel beam according to Table 15 (below). Install one anchor at each corner. Torque anchors according to the manufacturer's instructions.

Anchor	Embedment (in.)	Minimum Edge Distance (in.)
1/4" wedge	2"	3"
3/8" sleeve	1-1/4"	2"
1/8" weld	1" long at each corner	N/A

Table 15: Rigid floor-mounted anchor sizes.



These anchor/weld selections apply to equipment in which the height of the center of gravity (center of equipment mass) is less than twice the base length AND twice the base width.

Roof-mounted equipment

Anchor equipment to a concrete deck, a wood beam, or directly to a steel structural shape according to Table 16 (page 131). Install one anchor at each corner. Torque anchors according to the manufacturer's instructions.

Anchor	Embedment (in.)	Minimum Edge Distance (in.)
1/4" wedge	2"	3"
3/8" sleeve	1-1/4"	2"
3/8" lag	1-1/2"	1-1/2" to edge of wood and 3" from end
1/4" steel bolt	N/A	1/2"
1/8" weld	2" long at each corner	N/A

Table 16: Roof-mounted anchor sizes for rigid connections.



These anchor/weld selections apply to equipment in which the height of the center of gravity (center of equipment mass) is less than twice the base length AND twice the base width.

Suspended equipment

Rigidly suspend equipment from the building structure above with angles or rods and cables according to Table 17 (below and next page). Torque anchors according to the manufacturer's instructions.

Vertical threaded rod	Quantity	Anchors per Rod
1/2" rod with rod stiffener	One on each corner	1

Table 17: Suspended equipment anchor sizes for rigid connections (table continued on next page).

Anchors: Sizes for Equipment Weighing Less than 400 Pounds

Rod anchor	Embedment (in.)	Minimum Edge Distance
1/2" wedge	2-1/4"	3-1/2"
1/2" sleeve	2-1/4"	3-1/2"
3/8" lag bolt	2"	1-1/2" to edge of wood and 3" from end
1/2" steel bolt	N/A	1"

Cable	Quantity	Anchors per cable
1/8" seismic cable	4 at 45 degrees, one from each corner	1

Cable anchor	Embedment (in.)	Minimum Edge Distance (in.)
1/2" wedge	2-1/4"	3-1/2"
1/2" sleeve	2-1/4"	3-1/2"
3/8" lag bolt	2"	1-1/2" to edge of wood and 3" from end
1/2" steel bolt	N/A	1"

Table 17 (continued): Suspended equipment anchor sizes for rigid connections.

SPECIAL CASES
Cables

The three ways to assemble a cable connection are by using:

- Bolts with center holes (page 134).
- Ferrule clamps (page 135).
- Wire rope grips (page 137).

Other end fittings may be acceptable.

Cables should be installed at a 45-degree slope. Where interferences are present, the slope may be a minimum of 30 degrees or a maximum of 60 degrees.



Figure 149: Cable attachments.

END OF DETAIL.

Bolts with center holes

The manufacturer provides this type of cable assembly, along with the cables, mounting bolts with holes, and brackets that attach directly to the building structure or equipment frame. Assemble the cable as shown below.

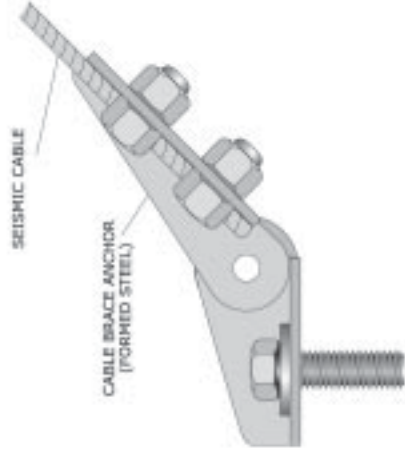

Figure 150: Cable attached with bolts to a bracket.

Step 1: Drill anchor holes in the building structure as required

Step 2: Attach brackets to both the building and the equipment frame

Step 3: Cut the cable to desired length and slide it through the holes in the bolts

Step 4: Tighten the cable

For rigid connections, pull the cable hand tight. For isolated components, pull the cable hand-tight and let out 1/8" slack. Avoid using too much tension or too much slack.

Step 5: Torque bolts



Torque bolts per manufacturer's recommendations.



Overtorque may damage cables.

END OF DETAIL.

Ferrule clamps

Ferrule clamps may be connected to various types of attachments. Figure 151 (below) and Figure 152 (page 136) show attachments and identify the parts (ferrules, sleeves, and thimbles) used in the assembly.



Ferrules must be made of steel, zinc-plated copper, or steel alloys (including stainless steel). Do not use aluminum ferrules.

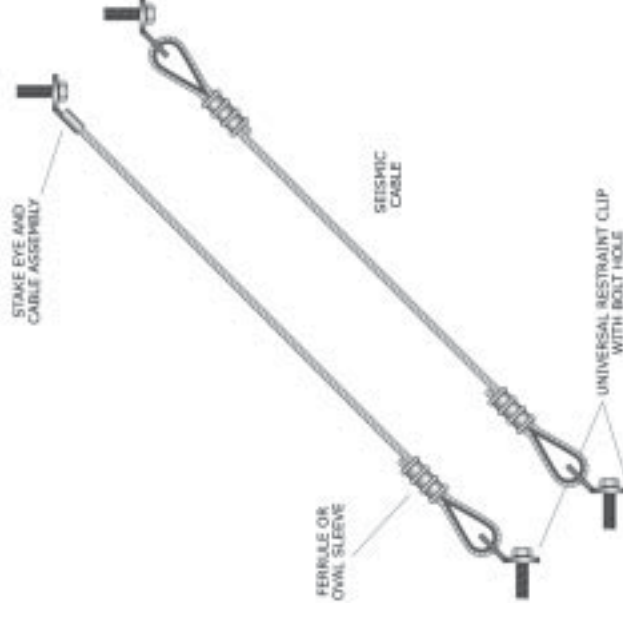

Figure 151: Ferrule assemblies.

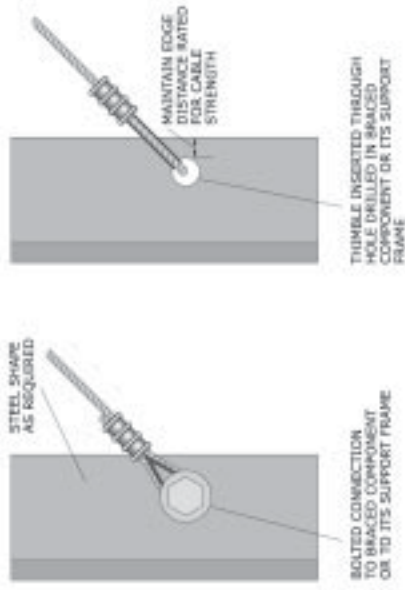

Figure 152: Ferrule attachments.

Step 1: Install brackets with mounting holes, eye-bolts, or drill mounting holes

Install brackets with mounting holes to the structure. Attach cables to the top of cord angles. See Suspended Attachments (page 71).

Step 2: Cut the cable to the desired length and slide the oval ferrule (sleeve) onto the cable

Step 3: Wrap the cable around the thimble and pass it through the mounting bolt or holes and back through the ferrule

Step 4: Tighten the cable

For rigid connections, pull the cable tight. For isolated components, leave a small amount of slack. Avoid using too much tension or too much slack.

Step 5: Crimp the ferrule or oval sleeve two or three times as specified in the cable or ferrule manufacturer's instructions

Use crimp tools and gauges specified by the manufacturer. Crimp and verify the depth of the crimp using a gauge.

END OF DETAIL.

Wire rope grips

Installing cables attached with wire rope grips is similar to attaching ferrule clamps, as shown below.

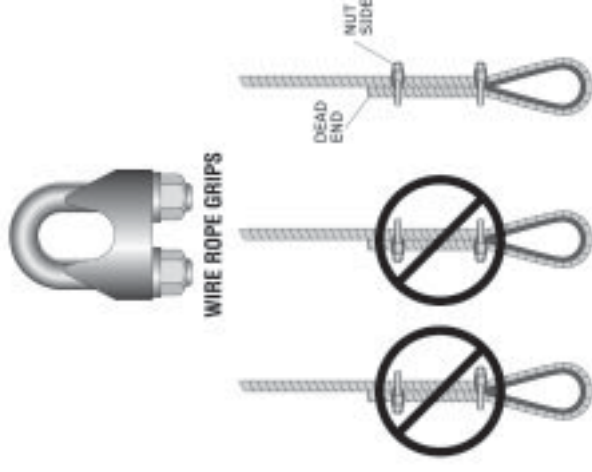

Figure 153: Wire rope grip assemblies.

Figure 153 clarifies the orientation of wire rope grips.

Step 1: Install brackets with mounting holes, eye-bolts, or drill mounting holes

Step 2: Cut cable to the desired length and slide three wire rope grips and thimbles onto the cable

Step 3: Pass the cable through the mounting bolt or holes provided and then back through each of the wire rope grips



Use thimbles for all cable installations with wire rope grips.

Step 4: Tighten the cable

For rigid connections, pull the cable tight. For isolated components, leave a small amount of slack. Avoid using too much tension or too much slack.

Step 5: Torque all bolts evenly

Use the turn-of-nut tightening method described in Step 3 of Steel Bolt Connections (page 124).



DO NOT OVER-TIGHTEN. See Table 14 (page 124).

END OF DETAIL.

Control Panels

Control panels may be built into units, mounted in a separate electrical panel attached to equipment assemblies, or mounted as a separate electrical panel attached to the building structure.



Be sure to refer to approved construction documents and specifications, seismic restraint submittals, and the manufacturer's instructions.



If an electrical panel is mounted separately from the unit and the unit is vibration-isolated, use flexible electrical connections to allow for differential movement.

Step 1: Select control panel support configuration

If the control panel is:

- Built into the equipment, no other action is needed.
- An electrical panel attached to the assembly, check that the attachment is rigid and tight. No other action is needed.
- A remote panel attached directly to the building structure or attached using support angles or struts, support the panel. The four ways of supporting control panels are by attaching them to:
 - An aluminum plate extending from the floor to the ceiling. The aluminum plate is attached to the floor and ceiling with angles, as shown on the left in Figure 155 (page 140).
 - A double-strut support spanning the floor and ceiling as shown on the right in Figure 155 (page 140). Struts are attached to the building structure with small angle clips.
 - Vertical angles or strut extending down to the floor with angles slanted back to the floor as shown in Figure 154 (page 140). This is the typical method. Details are shown in Figure 156 (page 141).
 - Walls with wall anchors as shown in Figure 157 (page 142).



Figure 154: Typical control panel support using angles. Additional angle supports may be required (see below).



Figure 155: Two different ways to support control panels: using a metal plate attached to floor and ceiling with steel angles (left); using struts extending to floor and ceiling (right).

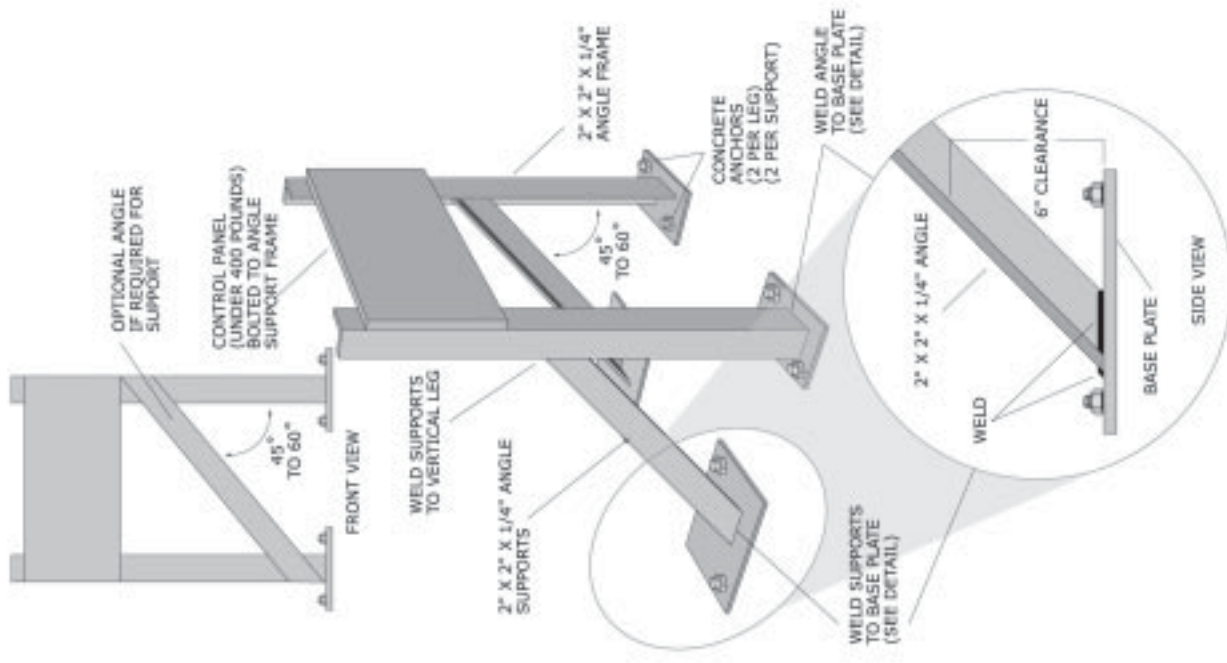

Figure 156: Angle assembly support from floor.

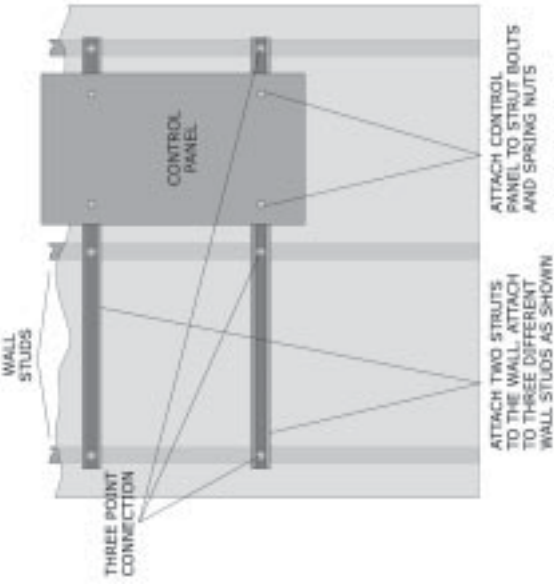

Figure 157: Direct attachment of a strut assembly support to wall.

Step 2: Assemble the mounting frame

Use bolts or weld the support framing together as shown in Figures 154 to 157 (pages 140 to 142). See Steel Bolt Connections (page 123), or Welding (page 128) for more information.

Step 3: Attach the mounting frame to floor or wall with anchors

Locate and mark hole locations in the building structure. Install the anchors. See Anchors (page 104) for more information.

Attach the mounting frame to the building structure.

- To attach strut angles for strut floor-mounted supports, see Figure 155 (page 140).
- To attach bases for angle floor-mounted supports, see Figure 156 (page 141).
- To attach strut to wall studs, see Figure 157 (above).

Step 4: Attach control panel to frame with a minimum of four steel bolts

See Steel Bolt Connections (page 123).

END OF DETAIL-

Housekeeping Pads



Be sure to refer to approved construction documents, specifications and the manufacturer's instructions.

The construction of housekeeping pads is shown below.

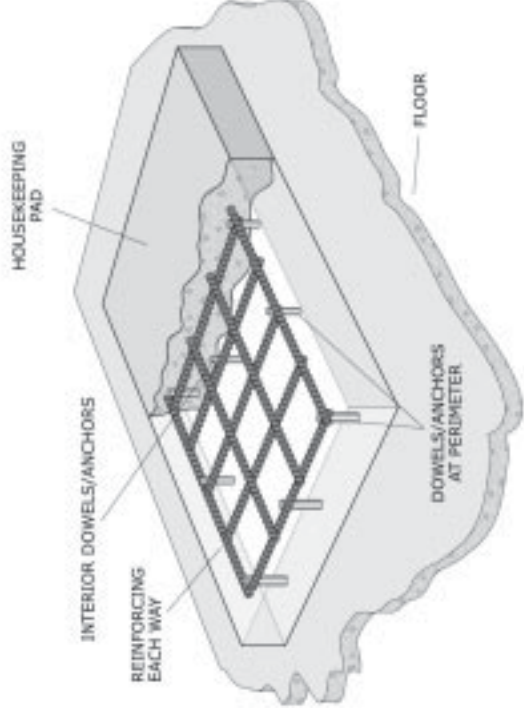

Figure 158: Housekeeping pad.

The housekeeping pad must be a minimum of one inch thicker than the anchor hole depth, or as required for the concrete anchors shown in Figure 159 (page 145).



Housekeeping pads must be designed for the equipment weight and seismic load.

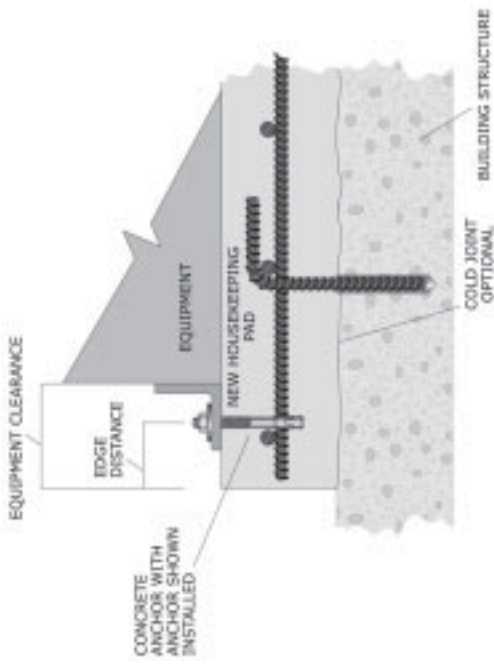

Figure 159: Housekeeping pad in section view.



If edge distance is not met, get an evaluation from your supervisor.

Dimensions for the housekeeping pad footprint must be large enough for the equipment, attachment steel (as required), and the edge distance of concrete anchors (see Anchors, page 104), as shown in Figure 160 (below).

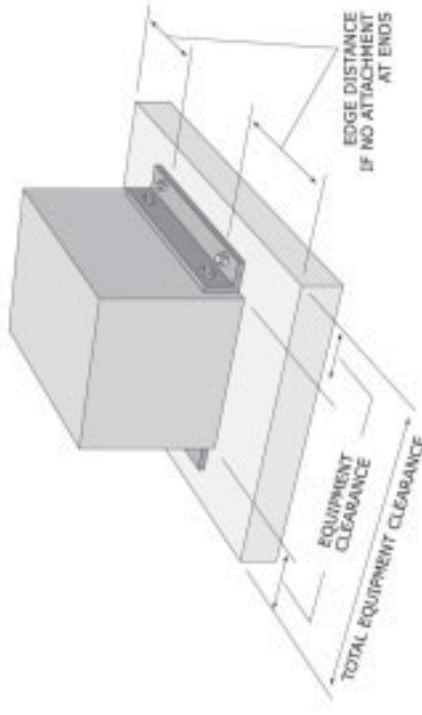

Figure 160: Housekeeping pad dimensions.

Step 1: Install dowels into the floor

Attachment details for dowels are shown in Figure 161 (below).

- Use measurements and approved construction documents to lay out the size of the dowels and the dowel pattern.
- Coordinate the location of embedded "Z" bar shown in Figure 161 with the concrete subcontractor.

Obtain the size of doweling and reinforcement from approved construction documents, specifications, or the manufacturer's instructions. Exterior dowels must be 1/2" to 1" in diameter. Interior dowels must be 3/4" in diameter.

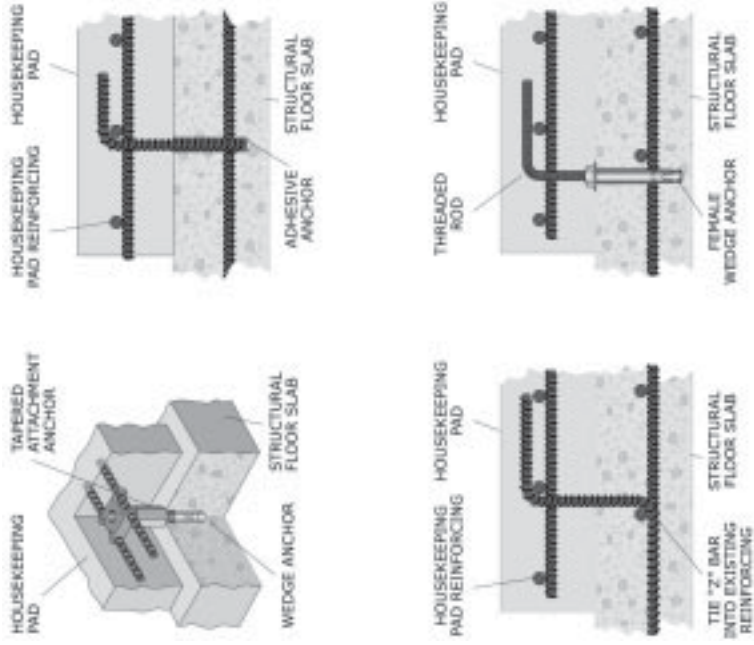

Figure 161: Doweling to the building floor.

Step 2: Assemble reinforcement

Assemble the reinforcement as shown in Figure 158 (page 144). Connect the dowels using wire.

Step 3: Pour concrete and allow to cure

Step 4: Drill holes and attach the equipment to concrete after the concrete has cured

END OF DETAIL-

Lighting

The three basic ways to attach lighting fixtures are:

- Directly to the building structure (this page).
- In suspended T-bar ceilings (page 149).
- Pendant-mounted (page 150).

Directly to the building structure

Step 1: Locate the attachment points



Use manufacturer's recommendation to attach the fixture to the building structure.

Use anchors to attach to masonry or concrete walls. Toggle bolts may be used for drywall construction if allowed by the approved construction documents.

Step 2: Attach the anchors to the building structure

Use brackets supplied by the manufacturer. See Anchors (page 104) for instructions on installing the anchors.

In suspended T-bar ceilings

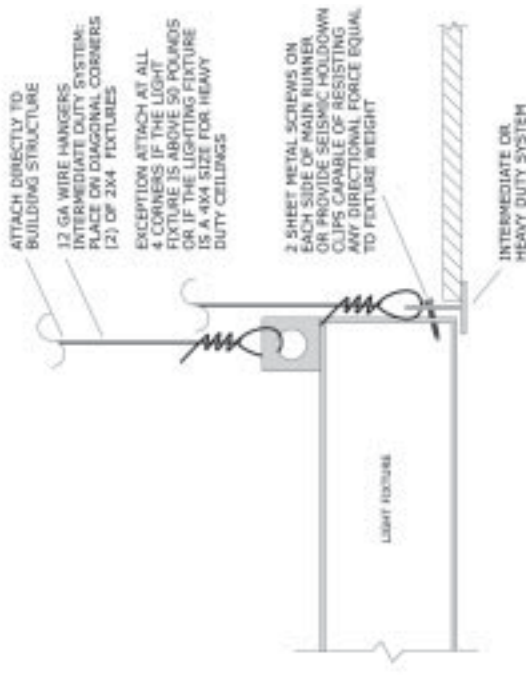

Figure 162: Typical ways to attach light fixtures in suspended T-bar ceiling.

 **Do not allow light fixture hanger wires to contact piping or ductwork as this may result in vibration or noise problems.**

 **Install splay braces on lights as required by approved construction documents.**

Step 1: Verify all T-bar ceiling runners are securely attached to the building structure as required by approved construction documents

This work is usually performed by a different subcontractor.

Step 2: Install lighting fixture into the T-bar ceiling runners

Special Cases: Lighting

Step 3: Attach lighting fixture to ceiling runners using screws or clips rated for the weight of the fixture

Attachment to the T-bar ceiling can be made with screws as shown in Figure 162 (page 149) or with clips provided by the lighting manufacturer.

Step 4: Run wires directly from the light fixture and attach to the building structure with anchors.

For instructions on installing anchors, see Anchors (page 104). You may use power-actuated anchors if the anchors are rated for seismic use and have a tension rating (see Power-Actuated Anchors on page 122).

Pendant-mounted

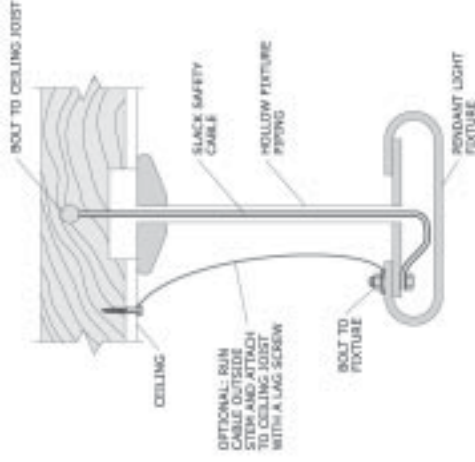

Figure 163: Pendant light fixture attachment

Step 1: Attach light fixture to ceiling

Step 2: Install safety cable

Safety cable should be bolted to light fixture and extended up to building structure. Safety cable may be internal to the fixture assembly or exposed.

END OF DETAIL.

ANCHOR SELECTION GUIDE

Power-Actuated

Description

Threaded Studs

Used in cases where the fastened equipment is to be removed later, or where shimming is required.

Threaded studs for concrete have a 0.140" to 0.180" shank diameter, with typical penetration of 3/4" (minimum) to 1-1/2" into concrete.

Threaded studs for steel plate applications have a 0.140" to 0.180" shank diameter when the steel plate thickness is 3/16" or greater.

Drive Pins

Used to directly fasten equipment for permanent installation.

Drive pins used for concrete have a 0.140" to 0.180" shank diameter, with typical penetration of 3/4" minimum to 1-1/2" into concrete.

Drive pins for steel plate applications have a 0.140" to 0.180" shank diameter when the steel plate thickness is 3/16" or greater.

Warning

Safety is the primary concern when using power-actuated tools (PAT). PAT tools pose the greatest risk to the operator and others in the area of use. Observe the following safety precautions:

Typically not used for equipment weighing more than 40 pounds.

Never allow a tool to be used until the operator is properly trained for the specific tool and application.

Never use a tool unless all safety features are functioning properly.

Always have the operator and others around wear personal protective equipment (PPE).
Never use more powerful loads than required for the particular application.

Always be aware of the potential of the fastener passing through the substrate or being deflected from its intended target.

Make sure that all areas are clear behind and around the target area.

Have an action plan in place to properly handle and dispose of misfired loads.

Always make sure the tools are low velocity and not standard velocity. (Standard velocity tools are not typically allowed on most jobsites because of the danger.)

Authorities having jurisdiction may require a license to use power-actuated anchors.

Adhesive	
Description	Warning
<p>Capsule Spin-In Adhesive mixes in the hole when the anchor is drilled by a rotary hammer drill only. Various strengths and types of rods or fasteners can be used. Multiple types of coatings on rods are available. Most commonly used in concrete; some might be suitable for use in other substrates. Most capsules cure quickly compared to epoxy.</p>	<p>Do not over-spin during installation. The rod must have a roof cut end with a single or double 45-degree angle/bevel for mixing. The hole must be clean and dry to achieve the maximum strength. Rod must be clean and must not be disturbed during curing. Many capsules produce strong vapors during the curing process. Check the MSDS sheets or with your supervisor to determine if masks are required.</p>
<p>Capsule Hammer-in Adhesive mixes in the hole when the rod is driven by a hammer. Various strengths and types of rods or fasteners can be used. Multiple types of coatings on rods are available. Most commonly used in concrete; some might be suitable for use in other substrates. Most capsules cure quickly compared to epoxy.</p>	<p>The hole must be clean and dry to achieve the maximum strength. Rod must be clean and must not be disturbed during curing. Many capsules produce strong odors during the curing process. Check the MSDS sheets or with your supervisor to determine if masks are required.</p>

Adhesive (cont.)	
Description	Warning
<p>Epoxy Used by mixing two or more components with a mixing nozzle at the point of application. Can be used with multiple forms of fasteners or as an adhesive. Many brands can be used in wet, damp, or dry conditions. Many formulas are allowed for use for USDA food processing areas. Some may be able to be used overhead. Permitted many times in freeze-thaw and severe weather conditions. Allows minimal edge distance and anchor spacing. Typical shelf life greater than that of other adhesives used for anchoring. Not as susceptible to damage from high storage temperatures.</p>	<p>Typically requires long curing times compared to that of other adhesives. Can be virtually odor free or can emit a strong odor, depending on the formula. Can be difficult to apply if the epoxy is thick. Generally not suggested for use at temperatures below 32 degrees F. Most epoxies require holes to be cleaned to obtain maximum values. Check the MSDS sheets or with your supervisor to determine if masks are required.</p>
<p>Acrylic Adhesive Dispenses and cures quickly. Some adhesives can be used overhead. Some adhesives can be installed in damp or water-filled holes. Typically can be used with many fastening devices such as threaded rod, dowels, and anchors.</p>	<p>Many types of acrylics produce a strong odor during the curing process. Others have a minimal odor. Check the MSDS sheets or with your supervisor to determine if masks are required.</p>
<p>Adhesive Undercut Anchors Used in heavy-duty applications where substrate is of poor quality.</p>	<p>Generally purchased from the manufacturer as a complete anchoring system. Any substitution of materials must be authorized before installation.</p>

Externally Threaded	
Description	Warning
<p>Heavy Duty Undercut</p> <p>Used in heavy-duty applications. Typically two types: self-undercutting and adhesive.</p> <p>Self-undercutting types use a special undercutting drill bit similar to heavy-duty sleeve anchors except that they fill a cavity greater than the initial hole diameter.</p>	<p>May require special tools and specific drill bits. Typically cannot be used at variable embedment depths. Can be complicated to install. May be difficult to verify proper installation.</p>
<p>Wedge Anchor</p> <p>The most common concrete anchor for heavy- to light-duty applications. Many configurations are available for most applications. Made from a variety of materials.</p>	<p>Typically designed for static loads and not used with reciprocating engines or in situations where vibrations are present.</p>
<p>Heavy Duty Sleeve Anchor</p> <p>Expansion anchor for heavy-duty requirements.</p>	<p>A large hole is required for this anchor. Some anchors have metric diameters. Some have multiple parts that can be unassembled. If re-assembled improperly, the anchor may not perform properly. If the nut is removed after the stud is inserted in the hole, the stud could be partially separated from the expansion cone, causing a reduction in anchor strength, or be detached from the expansion cone, requiring anchor replacement. These conditions are not visible.</p>
<p>Center Pin Anchor</p> <p>Medium-duty expansion anchor. The anchor is correctly installed when the pin is completely inserted. Installation procedures are simple; no torque is required to set the anchor.</p>	<p>Typically designed for static loads and not used with reciprocating engines, motors or in situations where vibrations are present.</p>

Externally Threaded (cont.)	
Description	Warning
<p>Sleeve Anchor</p> <p>Universal anchor for light- to medium-duty applications. Multiple head designs fit many applications and can be installed in masonry.</p>	<p>A large hole is required for this anchor. Some anchors have metric diameters. Some have multiple parts that can be unassembled. If re-assembled improperly, the anchor may not perform properly. If the nut is removed after the stud is inserted in the hole, the stud could be partially separated from the expansion cone, causing a reduction in anchor strength, or be detached from the expansion cone, requiring anchor replacement. These conditions are not visible.</p>
<p>Concrete Bolts (continued on next page)</p> <p>Concrete bolts are recommended for use in dry interior applications.</p> <p>Concrete bolts may be acceptable in some cases for temporary use in exterior applications.</p> <p>Not all concrete bolts used in resisting earthquake or wind loads are appropriate and may be beyond the scope of the anchors abilities.</p> <p>Concrete bolts should not be subjected to vibratory loads such as those encountered by supports for reciprocating engines, crane loads, and moving loads.</p>	<p>Maintain equal or greater than minimum edge distance bolts or apply reduction factors if applicable.</p> <p>The embedment depth is the distance from the concrete surface to the bottom of the screw anchor.</p> <p>Maintain minimum slab thickness.</p> <p>Use ONLY a specific manufacturer's recommended method of installation.</p> <p>NEVER substitute one manufacturer's concrete bolt installation instructions for another manufacturer's instructions.</p> <p>DO NOT ASSUME one manufacturer's instructions are the same as another manufacturer's instructions.</p>

Externally Threaded (cont.)	
Description	Warning
<p>Concrete Bolts (cont.)</p> <p>Concrete bolts are limited to installation in uncracked concrete masonry. Cracking may occur from anchor location in tension zone of concrete member, anchor location in setting concrete member, and anchors subjected to seismic loads, wind loads, or moving loads.</p> <p>Concrete bolts are limited to non-fire-resistive construction unless appropriate data is submitted demonstrating that anchor performance is maintained in fire-resistive situations.</p>	<p>Some manufacturers use different diameter drill bits for the same nominal diameter concrete bolt. Use the proper diameter drill bit before installation. When a specific screw anchor manufacturer's drill bit diameter is not used, a reduction of capacity must be accounted for in the calculations. Other manufacturers may <i>recommend</i> the use of ANSI B212 matched diameter drill bits for use with their concrete bolts.</p> <p>Some manufacturers may allow power tools for installation and others may not.</p> <p>Some screw anchor manufacturers recommend not using an electric impact wrench when re-using the same hole.</p> <p>Some manufacturers allow piloting a new anchor hole; 1 or 2 addition applications or re-uses are possible. If the manufacturer allows the screw anchor to be reused, inspect for excessive wear or the capacity of the screw anchor.</p>

Internally Threaded	
Description	Warning
<p>Internally Threaded Undercut Anchor</p> <p>Used in heavy-duty applications. Typically come in two types: self-undercutting and those using a specialized undercutting drill bit. Anchors have internal threads. Shallow embedment and small edge distances and spacing are possible.</p>	<p>May require special tools and specific drill bits. Typically cannot be used at variable embedment depths. Can be complicated to install. May be difficult to verify proper installation.</p>
<p>Shell Anchor</p> <p>Flush-mount or sub-surface internally threaded anchor for medium- to light-duty applications. Comes in fractional and metric sizes and is available in a variety of materials.</p>	<p>A special setting tool is required and must be supplied by the anchor manufacturer. The setting tool is designed for each anchor size and style.</p>
<p>Others</p> <p>Similar to the wedge concrete anchor and used in heavy- to light-duty applications. Many configurations are available to fit most applications. Made from a variety of materials.</p>	<p>Typically designed for static loads and not used with reciprocating engines or in situations where vibrations are present.</p>

Light Duty Fastenings		Warning
Description		
Drive Pin (nail) Anchors (metal and plastic) Light-duty anchor with fast and easy installation in many substrates.		Use only for static loads. Typically not used in overhead applications. DO NOT USE FOR SEISMIC RESTRAINT
Concrete Screws Medium- to Light-Duty A variety of lengths and diameters are available. Often used for temporary anchorage.		Typically not used in situations where extensive vibrations are present. Requires the use of a special drill bit (some metric) supplied by the anchor manufacturer.
Special Style Head Wedge (Ring) Anchor Wedge anchor with integrated connection (head) designed for tie wires or suspended ceilings.		Typically designed for static loads and not used with reciprocating engines or in situations where vibrations are present.
Single and Double Expansion Shields Multi-purpose anchor used in concrete, Concrete Masonry Unit (CMU), brick, or stone. This anchor distributes fairly even pressure, making its use popular in CMU, brick, and natural stone. Typically used in conjunction with machine bolts, which can be removed and replaced.		Anchor material is malleable and the threads can be stripped. DO NOT USE FOR SEISMIC RESTRAINT

Light Duty Fastenings (cont.)		Warning
Description		
Lead Expansion Anchors Similar to expansion shields, but typically considered light-duty. Many can be used with a variety of screws or bolts. Quick and simple to install. Can be used in concrete, CMU, brick, or stone.		Anchor material is malleable and the threads can be stripped. Anchor should not be used in any applications. DO NOT USE FOR SEISMIC RESTRAINT
Toggle or "Molly"-type Anchors Light- to medium-duty anchor with easy installation in many substrates. No drilling is required for some anchor types or in some substrates. Some anchors are supplied with bolts or screws. Anchors are made from variety of materials and colors including plastic, zinc alloys, and steel.		May require a large hole. Anchor may or may not be reusable if the bolt is removed. Severe damage to the substrate can result if these anchors are removed after installation.

ELECTRICAL DANGER INSTRUCTION CHART

- ▶ Only qualified personnel familiar with proper voltage equipment are to perform work described in this set of instructions. Workers must understand the hazards involved in working with or near electrical circuits.
- ▶ Perform work only after reading and understanding all of the installation instructions in this manual and the manufacturer's literature.
- ▶ Turn off all power-supplying equipment before working on or inside equipment.
- ▶ Always use a properly rated voltage sensing device to confirm that the power is off.
- ▶ Beware of potential hazards. Wear Personal Protective Equipment (PPE) as required by NFPA-70E, and take adequate safety precautions.
- ▶ Replace all devices, doors, and covers before turning on the power to the equipment.
- ▶ All activities must be performed by qualified personnel in accordance with local codes.
- ▶ Precautions for circuit breakers:
 - The circuit breaker must be removed from its compartment and isolated from the voltage.
 - Control voltage must be in the open (O) position.
 - The circuit breaker must be in the open (O) position.
 - All circuit breaker springs must be discharged.
- ▶ Handle equipment carefully and install, operate and maintain it correctly in order for it to function properly. Neglecting fundamental installation and maintenance requirements may lead to personal injury, as well as damage to electrical equipment or other property.

Electrical Danger Instruction Chart

- ▶ Heavy equipment should be stabilized with straps and other tie-downs to reduce the possibility of tipping.
- ▶ Spreader bars must be evaluated by the appropriate design professional prior to lifting.
- ▶ When lifting, do not pass ropes or cables through lift holes. Use slings with safety hooks or shackles.
- ▶ Damaged vent housings can constrict proper air flow and expose the interior of electrical voltage compartment to weather.
- ▶ Do not make any modifications to the equipment or operate the system with interlocks and safety barriers removed. Contact your manufacturer's representative for additional instructions if the equipment does not function as described in this manual.
- ▶ Complete seismic installation and proper inspection of work prior to enabling the circuit breakers.
- ▶ Use out-of-service tags and padlocks when working on equipment. Leave tags in place until the work is completed and the equipment is ready to be put back into service.
- ▶ Restore all seismic restraints removed for maintenance to their original installation configuration and torque all bolts/anchors to their proper values.
- ▶ Carefully inspect your work area and remove any tools and objects left inside the equipment.
- ▶ Remove all tools, lifting assembly, and miscellaneous items left on the equipment prior to enabling the circuit breaker.
- ▶ All instructions in this manual and provided by the manufacturer are written with the assumption that the customer has taken these measures before performing any maintenance or testing.

A **Adhesive anchor** – A smooth or deformed steel bar or threaded rod, set in a predrilled hole in hardened concrete or masonry (including masonry units and mortar joints) that derives its holding strength from a chemical bonding compound placed between the wall of the hole and the embedded portion of the anchor.

Anchor – A device for connecting equipment and attachments to the building structure.

Attachments – Support systems used to connect equipment, pipe, conduit, or ductwork to the building.

Attachment type – Use of attachments to floors, walls, roofs, ceilings, and vibration isolators.

B **Bar joist** – Ceiling joists supporting intermediate floors or roof made from steel angles and steel bars.

Base plate – A steel plate used for support and anchorage of an angle support or vibration isolator.

Bed joint – A horizontal seam in a brick or concrete block wall. Also see **Head joint**.

Bolt diameter – Thickness or width of the outside of the threaded portion of the bolt.

Building structure – Steel, concrete, masonry and wood members or surfaces that transfer the weight of the building and equipment to the ground.

Bumpers – Angles or other steel shapes with elastomeric padding rigidly mounted to the building structure in a pattern around the equipment base to limit horizontal movement.

Busbars – A conducting bar (usually made of copper) that carries currents to various electric circuits.

C **Cabinet** – An enclosure designed for surface mounting or flush mounting that houses controls and electrical components.

Cable brace – A steel cable designed for use as a seismic sway brace for suspended equipment, conduit, cable trays or raceways. Also see **Pre-stretched cable**.

Cant strip – A material used to fill voids in roof flashing.

Cantilevered – A support member connected at one end and unsupported at the other end.

Cast-in-place – A steel shape embedded into concrete.

Cast-in-place anchor – A headed steel bolt set within a concrete form before concrete is poured.

Cold joint – An edge between two concrete surfaces.

Construction documents – Drawings, specifications, and manufacturer's instructions (approved by the appropriate design professional) that define the scope of a project and provide detailed information to seismically restrain the equipment, conduit, or raceways. Also known as blue prints.

Counter flashing – A light-gauge sheet metal folded support or equipment frame to shed water or snow onto the roof.

Curb – Raised or enclosed framework that supports equipment.

Cure – To gain internal strength over time to withstand external forces.

Cure time – The total time it takes for the material to be at an absolute full load capacity.

D **Design professional** – The responsible party, recognized by the authority having jurisdiction, working within their scope of qualifications and providing design services.

Differential movement – The movement between two objects or surfaces.

E **Edge distance** – The distance between a concrete anchor and the edge of a concrete surface or concrete cold joint.

Elastomeric – A material with flexibility in all directions that will return to its original shape if removed from its environment.

Elastomeric mount – A molded one-piece mount with surfaces designed to attach the equipment to the structure without metal-to-metal contact.

Elastomeric pad – A resilient natural or synthetic rubber-like pad used to reduce sound, shock and high frequency vibrations.

Embedded plate – A steel plate set into concrete to permit a welded attachment.

Embedment – How far a post-installed anchor is inserted into a hole in concrete or wood after the anchor is set in place and torqued.

Embedment depth – See **Embedment**.

Enclosure – A case or housing to protect electrical components.

Equipment – Any mechanical or electrical component.

Expansion anchor – A post-installed anchor that uses some form of wedge or shell held against the edge of a drilled hole with friction.

F **Ferrule** – A small metal tube that can be crimped around steel cables.

Fiberglass pad – A pad with a core of resilient fiberglass material covered by a moisture resistant resilient shell used to reduce sound, shock and high frequency vibrations.

Fillet weld – A type of weld between two pieces of steel where the welded surfaces are at right angles.

Flashing – Metal, asphalt, or elastomeric material with one or more layers surrounding a roof penetration specifically designed to weatherproof the building.

Flexible connector – A connector designed to allow slight movement between a piece of equipment, component, or system and another system in the event of an earthquake.

Flexible mounted equipment – A piece of equipment supported on or from a vibration isolator.

G **Gel time** – A specified amount of time for an adhesive to form a jelly-like substance with strength to hold its own weight or the weight of a light steel anchor.

Grommet – A rubber or elastomeric bushing-shaped ring that may be used in restrained springs, snubbers, or with bolts to provide a cushioned or flexible connection.

H **Hand tight** – The force applied by hand or with hand tools to bring two or more materials firmly in contact without a space.

Head joint – A vertical joint between two concrete blocks in a block wall or two bricks in a brick wall. Also see **Bed joint**.

Headed stud – A large bolt with a threaded shaft and a hexagonal-shaped bolt head typically used for embedment into concrete surfaces or in-filled masonry walls.

Height-saving bracket – A bracket used to accommodate the height of spring isolators without raising the equipment base more than a few inches.

Housed spring – A spring isolator with steel guides usually separated by an elastomeric sheet located on two opposite sides of the spring.

Housed spring isolator – A steel coil spring designed to be loaded in compression along the axis of the spring. Housed springs have a two-piece housing and mounting stud for the purpose of leveling equipment. The housing has limited lateral restraining capabilities and cannot resist uplift.

Housekeeping pad – A concrete pad under equipment that raises the elevation of the equipment above the building structure or structural slab.

- I** **Inertia base** – A heavily weighted base, usually made of concrete, that weighs more than the equipment it supports.
- In-filled block** – A concrete block wall whose cells are reinforced with rebar and filled with a sand-grout mixture.
- Isolators** – See **Vibration isolators**.
- L** **Leveling stanchions** – See **Stanchions**.
- Load path** – Seismic support of equipment and internal components that can be traced through connections and support steel to the building structure.
- Load transfer angles** – Angles bolted to equipment and to the building structure, transferring the weight and earthquake load through the angles to the building structure.
- Longitudinal brace** – A brace that restrains pipes, ducts, or raceways parallel to the longitudinal direction of the pipe, duct run, or raceway.
- O** **Open spring** – A spring isolator with a bolt attachment at the top of the spring for connecting to equipment without any horizontal support.
- Open spring isolator** – A steel coil spring designed to be loaded in compression along the axis of the spring. Open springs have a plate or cup on the bottom and top with a mounting stud.
- Oversized holes** – Bolt holes greater than standard bolt holes allowed by industry standards.
- P** **Pad-mounted** – Equipment mounted on a concrete structure not normally part of the building structure.
- Plug weld** – The weld of a plate or base plate to another metal surface where a plate is perforated with one or more holes, which are then filled with the weld filler material.

- Point load** – Weight and seismic forces that are focused to a single point connection to the building structure.
- Post and beam** – An elevated structure usually made from beams resting on posts or stanchions connected to the building structure.
- Post-installed anchor** – Anchors installed after the concrete has reached its specified strength.
- Post-tension (pre-stressed) building** – A concrete building structure surface with internal steel cables that are stretched and restrained to permanently compress the concrete surface.
- Pre-manufactured curb** – A sheet metal curb manufactured at a factory and sent to the job site.
- Pre-manufactured vibration isolation curb** – A factory-built curb designed to attach equipment to a roof and containing vibration isolators, which allow for slight movement of the equipment.
- Pre-stressed beam** – A concrete beam bonded to steel in tension in the form of a beam.
- Pre-stretched cable** – Cable that is stretched after it is manufactured.
- R** **Raceway** – A channel (conduit or open raceway) designed to hold wires and cables or busbars.
- Rated spring deflection** – The dimension that a spring will compress when the weight of equipment is applied.
- Rehabilitation** – A new installation within an existing facility.
- Restrained elastomeric mount** – An elastomeric mount with an integrated seismic restraining mechanism that limits movement in all horizontal and vertical directions.
- Restrained spring** – A vibration isolator containing a spring enclosed in a welded or bolted steel housing that limits movement of the spring equipment attachment in all directions.

Restrained spring isolator – A steel coil spring designed to be loaded in compression along the axis of the spring. Restrained springs have a housing with integrated seismic restraining mechanisms, that limit movement in all horizontal and vertical directions.

Rigid-mounted equipment – Equipment solidly braced or bolted directly to the building structure without vibration isolation.

Screen – A tube of steel wire mesh used as an adhesive anchor for anchoring to block or brick walls.

Seismic cable – A galvanized steel or stainless steel braided rope that is pre-stretched.

Seismic restraint device – An attachment device designed to restrict movement of equipment during an earthquake.

Seismic restraint submittals – Documents created by contractors or vendors describing the means and methods for installing seismic restraint devices and submitted for design approval.

Seismic rod clamp – A clamping device for attaching rod stiffeners to a vertical threaded rod.

Seismic separation joint – A space provided between buildings or portions of a building to prevent contact caused by differential movement during an earthquake. For piping, ductwork and conduits crossing the seismic joint, the systems are connected with a flexible component that allows for differential movement at least twice the width of the seismic separation joint.

Self-drilling – A special type of concrete shell anchor with cutting teeth for drilling into concrete.

Self-tapping – Either a sheet metal screw with blades on the end (similar to a drill bit), allowing the screw to drill a hole and embed itself into a steel shape, or a concrete screw with a point and specially designed threads allowing the screw to grip the concrete and embed itself into the concrete.

Set time – The specific time required for material to harden when a light load may be applied.

Shallow concrete anchor – Any anchor with an embedment depth measuring less than 1/8th of its diameter.

Sheet metal curb – A square or rectangular box made from galvanized steel sheets used to connect equipment to a roof.

Shim – A thin wedge of material used to fill a space.

Snubber – A seismic restraint device used on isolated systems with an air gap and elastomeric bushing or oil-filled hydraulic cylinder (shock absorber) restricting the rapid motion of a pipe.

Snug tight – The force applied by hand or with hand tools to bring two or more materials firmly in contact with one another without a space.

Solid brace – A steel angle or strut channel designed for use as a seismic sway brace for suspended equipment, piping, ductwork, conduit, cable trays, or raceways.

Spring-isolated – See **Vibration-isolated**.

Stanchions – Columns or short structural steel shapes placed vertically that connect to equipment bases or horizontal structural steel frames to provide equipment support.

Structural steel shapes – A manufactured steel component in a variety of shapes.

Strut – A manufactured steel shape in various U-shaped patterns and sizes.

Strut frame – Steel framing made from strut members that act as a support to transfer the equipment weight to the building structure. See **Strut**.

Sway brace – Solid braces or cable braces that provide seismic restraint.

T

- Tendons** – Steel cables used in post-tension buildings. Also see **Post-tension building**.
- Thimble** – A metal spacer used on a cable to protect it from being bent and damaged.
- Toe of the weld** – The edge of a fillet weld.
- Torque** – A turning force around a bolt applied by twisting a bolt head or nut so the components will not separate.
- Transverse brace** – A brace that restrains pipes, ducts, or raceways perpendicular to the longitudinal direction.
- Turn-of-nut method** – A process to properly torque a bolt without a special tool like a calibrated torque wrench. See **Hand tight** and **Snug tight**.

V

- Vibration-isolated** – Allows flexible motion between equipment, piping, ductwork, conduit, cable trays, or raceways and the building structure.
- Vibration isolators** – Components containing resilient elements such as steel springs, air springs, molded pre-compressed fiberglass or elastomeric pads used to separate vibrating equipment, piping and ductwork from the building structure.

W

- Web** – A thin metal strip in a structural steel shape.
- Weld base material** – The material composition of an item being welded.
- WPS** – Weld Procedure Specification is required for all welding in accordance with American Welding Society D1.1. The WPS defines the essential variables and their limits for the weld and must be in the vicinity where the weld is occurring.

INDEX

A

- acceptable gap 110
- anchor 104-132, 162
- adhesive 104, 105-110, 117, 118, 151-153, 162
- cast-in-place 72, 104, 111, 163
- concrete bolt 104
- concrete screw 114, 119
- drywall 114-121
- embedded plates 104
- externally threaded 154-156
- gap 110
- general 104
- internally threaded 157
- lag bolts 104, 112-113, 114, 120
- light-duty fastenings 158-159
- masonry 104, 114-121
- non-adhesive 104, 105-110
- post-installed 73, 105
- power-actuated 122, 151
- sheet metal screw 114, 120
- shell 104, 105-110
- sizes for equipment less than 400 pounds 130-132
- sleeve 104, 105-110, 114, 120
- steel bolt 104, 123-127
- through-bolt 75, 116
- toggle bolt 114, 120
- umbrella 114, 119
- undercut 104
- wedge 104, 114, 120
- welding 128-129
- anchor selection guide 151-159
- angle 30-33, 35, 37-39, 43-44, 47, 49, 56-58, 60, 78-80, 83-84, 100, 110
- attachment type 51-103, 162
- rigid floor-mounted/pad-mounted 51-64
 - see *also* rigid floor-mounted/pad-mounted attachment
 - roof-mounted 65-70
 - see *also* roof-mounted attachment
 - suspended 71-86
 - see *also* suspended attachment
 - vibration-isolated/floor-mounted 87-97
 - see *also* vibration-isolated/floor-mounted attachment
 - wall-mounted 98-103
 - see *also* wall-mounted attachment
- automatic transfer switches 4-5

- B**
 bar joist 74, 77, 162
 base
 inertia, concrete-filled 94, 96, 165
 plate 31, 35, 162
 round 58
 battery racks 26-27
 block walls 115
 brace 32-33, 43-45, 47, 49, 100, 162
 bracket 32, 81, 94, 98, 110
 bumpers 89, 162
 bypass-isolation switch 4
- C**
 cable 38, 41, 45, 49, 63, 71-78, 162
 attach using 38, 41, 45, 49, 63, 71, 76-78, 81, 83-85, 133-138
 bolts with center holes 134-135
 ferrule clamps 135-136
 wire rope grips 137-138
 cable trays 30-50 *see also* raceways
 capacitor banks 14
 cast-in-place anchors 72
 bolting equipment to 111
 chain 86
 circuit interrupters 16
 clamp 32-33, 43-45
 clevis hanger 36-42
 concrete
 bolt 104
 drilling 107
 joint 60
 pouring 54, 147
 screw 114, 119
 slab 73
 conduit 30-50 *see also* raceways
 control panels 139-143
 curb 15
 isolation 166
 curing 109, 163
- D**
 disconnects 18-19
 dowel 146
 drywall anchor 114-121

- E**
 elastomeric pads 96-97
 electric unit heater 28-29
 electrical water heater attachment 101
 electrical danger instruction chart 160
 embedded plates 58, 104, 128, 163
 embedment depth 107, 164
 equipment 4-29, 164
 automatic transfer switches 4-5
 battery racks 26-27
 control panels 6-7
 generators 8-9
 less than 400 pounds, anchor sizes for 130-131
 lighting 10-11
 load centers 12-13
 low voltage: substations, capacitor banks, switchboards, and switchgears 14-15
 medium to high voltage: switchgears, circuit interrupters, substation circuit breakers, and walk-in enclosures 16-17
 meters and disconnects 18-19
 motor control centers and variable frequency drives 20-21
 multi-media racks 22-23
 panelboards 12-13
 setting/moving in place 54, 59, 64
 transformers 24-25
 typical 3, 5, 7, 9, 11, 13, 15, 17, 19, 21, 23, 25, 27, 29
 type of installation 3, 5, 7, 9, 11, 13, 15, 17, 19, 21, 23, 25, 27, 29
 uninterruptable power supplies 26-27
 unit heaters and tanks 28-29
- F**
 ferrule clamps 135-136, 164
 flashing 65, 67, 68, 70, 164
 floor-mounted
 anchor sizes for 130
 attachments *see* rigid floor-mounted/pad-mounted attachments
 automatic transfer switches 4-5
 capacitor bank 14-15
 circuit interrupter 16-17
 computer rack 22-23
 control panels 6-7
 equipment rack 22-23
 generators 8-9
 low voltage switchboard 14-15
 media equipment 22-23
 meter center 18-19
 motor control center 20-21

- floor-mounted continued*
 - open multi-media rack 22-23
 - panelboard 13-14
 - substation 14-17, 24-25
 - switchgear 14-17
 - transformer, dry-type 24-25
 - uninterruptible power supply 26-27
 - unit heaters and tanks 28-29
 - flush-mounted
 - control panel 6
 - light 10
 - load center 12
 - frame 53, 81
- G**
- gap see acceptable gap
 - generators 8
 - grouted plate 110
- H**
- head joint 165
 - hole
 - cleaning 108
 - clearance 112
 - depth 107
 - drilling 106
 - lead 112
 - oversized, repair of 54
 - housekeeping pad 144-147, 165
- L**
- lag bolts 104, 112-113, 114, 120
 - lighting 10-11
 - load centers 12-13
 - low voltage: substations, capacitor banks, switchboards, and switchgears 14-15
- M**
- masonry and drywall anchors 104, 114-121
 - medium to high voltage: switchgears, circuit interrupters, substation circuit breakers, and walk-in enclosures 16-17
 - meters 18-19
 - motor control center 20-21
 - multi-media racks 22-23

O

oversized hole, repairing 54

P

- pads 89
- pad-mounted see *also* rigid floor-mounted/pad-mounted
 - attachment
 - generator 8-9
 - substation 16-17, 24-25
 - transformer 24-25
- panelboard 12-13
- plate 38, 84, 128-129
- post and beam 65-67, 167

R

- raceways 30-50
 - supported from the floor 31-34
 - supported from the wall 34-35
 - suspended using clevis hanger braced
 - at the restraining bolt 36-38
 - suspended using clevis hanger braced
 - at the hanger rod 39-40
 - suspended using clevis hanger and 4-way cable brace 41-42
 - suspended using pipe clamps 43-46
 - suspended with a trapeze support system 47-49
 - crossing seismic joints 50
- raised floor 61-64, 167
- rebar 107
- repair oversized holes 54
- rigid floor-mounted/pad-mounted attachment
 - anchors sizes for 130
 - beneath a raised floor 61-64
 - directly to the floor/pad 51-55
 - using additional structural steel shapes 55-59
 - using bumpers to restrict horizontal movement 60-61
- rods 36-40, 43-49, 71-81, 83-85, 125-127
- roof-mounted attachment
 - anchor sizes for 130-131
 - to a wood frame 68
 - using leveling stanchions—post and beam 65-67
 - using restrained springs on leveling stanchions 69-70
- rubber mounts 89

S

- safety switches 18
- screen insert 117-118
- seismic
 - cable 83, 84
 - joint 50
- sheet steel 52
- snubbers 88, 94-97, 168
- special cases
 - cables 133-139
 - control panels 139-143
 - housekeeping pads 144-147
 - lighting 148-150
- spring
 - housed 87, 165
 - isolator 82, 83, 90-97
 - open 87, 94-97
 - restrained 69-70, 88, 90-93, 103, 167
- stanchion 65-67, 69-70
- steel beam 53
- steel bolt connections
 - bolted to a concrete floor 51-55, 123-124
 - bolting two structural shapes together 125
 - bolting a threaded rod to steel shapes or strut 55, 59, 100, 125-127
- steel shape 100-102, 128
- strap 33-35
- structural framing 53, 100-102
- strut 30-33, 35, 37-39, 43-47, 49, 78-80, 168
- substations 14, 16
- suspended attachment
 - anchor sizes for 131-132
 - chain mounted 86
 - double rod attachment—bolted to the building 84-85
 - isolated using threaded rods and horizontal cable supports 81-83
 - rigid using 4 threaded rods with horizontal cable supports 71-78
 - rigid using angle/strut supports 78-80
- switchboards 14
- switchgears 15, 16

T

- t-bar ceilings 149-150
- tanks 28-29
- tendons 30, 169
- thimble 137, 169
- torque 43-45, 61, 138, 169
- transformers 24-25
- transverse supports 30, 32, 33, 37, 39, 43, 47
- trapeze support 47-48
- turn-of-nut method 124, 169

U

- uninterruptable power supplies 26-27
- unit heaters 28-29

V

- variable frequency drives 20-21
- vibration-isolated/floor-mounted attachment
 - on elastomeric pads with isolated anchors 96097
 - on open isolators combined with snubbers 94-97
 - on restrained isolators 90-93
- vibration isolators 87-97, 102-103

W

- walk-in enclosures 14
- wall-mounted attachment
 - directly to the wall 98-99
 - to additional structural shapes 100-102
 - vibration-isolated 102-103
- webs 169
- weld 45, 55, 57, 59, 65-66, 70, 92, 93, 100, 128-129, 169
- wire rope grips 137-138
- wood beam 73
- wood frame 68

Z

- "Z" bar 146