

NBS SPECIAL PUBLICATION **592**

U.S. DEPARTMENT OF COMMERCE / National Bureau of Standards

An Investigation of the Miyagi-ken-oki, Japan, Earthquake of June 12, 1978

REPRODUCED BY
**NATIONAL TECHNICAL
INFORMATION SERVICE**
U.S. DEPARTMENT OF COMMERCE
SPRINGFIELD, VA 22161

NATIONAL BUREAU OF STANDARDS

The National Bureau of Standards¹ was established by an act of Congress on March 3, 1901. The Bureau's overall goal is to strengthen and advance the Nation's science and technology and facilitate their effective application for public benefit. To this end, the Bureau conducts research and provides: (1) a basis for the Nation's physical measurement system, (2) scientific and technological services for industry and government, (3) a technical basis for equity in trade, and (4) technical services to promote public safety. The Bureau's technical work is performed by the National Measurement Laboratory, the National Engineering Laboratory, and the Institute for Computer Sciences and Technology.

THE NATIONAL MEASUREMENT LABORATORY provides the national system of physical and chemical and materials measurement; coordinates the system with measurement systems of other nations and furnishes essential services leading to accurate and uniform physical and chemical measurement throughout the Nation's scientific community, industry, and commerce; conducts materials research leading to improved methods of measurement, standards, and data on the properties of materials needed by industry, commerce, educational institutions, and Government; provides advisory and research services to other Government agencies; develops, produces, and distributes Standard Reference Materials; and provides calibration services. The Laboratory consists of the following centers:

Absolute Physical Quantities² — Radiation Research — Thermodynamics and Molecular Science — Analytical Chemistry — Materials Science.

THE NATIONAL ENGINEERING LABORATORY provides technology and technical services to the public and private sectors to address national needs and to solve national problems; conducts research in engineering and applied science in support of these efforts; builds and maintains competence in the necessary disciplines required to carry out this research and technical service; develops engineering data and measurement capabilities; provides engineering measurement traceability services; develops test methods and proposes engineering standards and code changes; develops and proposes new engineering practices; and develops and improves mechanisms to transfer results of its research to the ultimate user. The Laboratory consists of the following centers:

Applied Mathematics — Electronics and Electrical Engineering² — Mechanical Engineering and Process Technology² — Building Technology — Fire Research — Consumer Product Technology — Field Methods.

THE INSTITUTE FOR COMPUTER SCIENCES AND TECHNOLOGY conducts research and provides scientific and technical services to aid Federal agencies in the selection, acquisition, application, and use of computer technology to improve effectiveness and economy in Government operations in accordance with Public Law 89-306 (40 U.S.C. 759), relevant Executive Orders, and other directives; carries out this mission by managing the Federal Information Processing Standards Program, developing Federal ADP standards guidelines, and managing Federal participation in ADP voluntary standardization activities; provides scientific and technological advisory services and assistance to Federal agencies; and provides the technical foundation for computer-related policies of the Federal Government. The Institute consists of the following centers:

Programming Science and Technology — Computer Systems Engineering.

¹Headquarters and Laboratories at Gaithersburg, MD, unless otherwise noted; mailing address Washington, DC 20234.

²Some divisions within the center are located at Boulder, CO 80303.

U.S. DEPT. OF COMM. BIBLIOGRAPHIC DATA SHEET	1. PUBLICATION OR REPORT NO. NBS SP 592	2. Gov't. Accession No.	3. Recipient's Accession No. PBB1 116865
4. TITLE AND SUBTITLE An Investigation of the Miyagi-ken-oki, Japan Earthquake of June 12, 1978		5. Publication Date October 1980	6. Performing Organization Code
7. AUTHOR(S) Bruce R. Ellingwood		8. Performing Organ. Report No.	
9. PERFORMING ORGANIZATION NAME AND ADDRESS NATIONAL BUREAU OF STANDARDS DEPARTMENT OF COMMERCE WASHINGTON, DC 20234		10. Project/Task/Work Unit No.	11. Contract/Grant No.
12. SPONSORING ORGANIZATION NAME AND COMPLETE ADDRESS (Street, City, State, ZIP) Same as item 9.		13. Type of Report & Period Covered Final	14. Sponsoring Agency Code
15. SUPPLEMENTARY NOTES Library of Congress Catalog Card Number: 80-600116 <input type="checkbox"/> Document describes a computer program; SF-185, FIPS Software Summary, is attached.			
16. ABSTRACT (A 200-word or less factual summary of most significant information. If document includes a significant bibliography or literature survey, mention it here.) On June 12, 1978, a destructive earthquake with Richter magnitude of 7.4 occurred off the east coast of Miyagi Prefecture, Japan. Preliminary estimates by the National Land Agency of Japan indicated that the earthquake caused an equivalent of \$800 million in total damage. There is a cooperative agreement between the Governments of the United States and Japan termed the U.S.-Japan Program in Natural Resources (UJNR). Following the earthquake, it was arranged through UJNR that teams of U.S. structural engineers and geologists would visit Miyagi Prefecture and inspect the damage caused by the earthquake. This report assembles the information and collective experiences of the investigation team so as to describe the earthquake and document its effects. Field investigations conducted by geologists and structural engineers are described in detail and some of the implications for seismic resistant design and construction of structures in the United States are also discussed.			
17. KEY WORDS (six to twelve entries; alphabetical order; capitalize only the first letter of the first key word unless a proper name; separated by semicolons) Bridges; buildings; dikes; earthquakes; foreign engineering; geology; highways; housing; landslides; liquefaction; power plants; railroads; rock slides; seismicity; structural engineering.			
18. AVAILABILITY <input checked="" type="checkbox"/> Unlimited <input type="checkbox"/> For Official Distribution. Do Not Release to NTIS <input checked="" type="checkbox"/> Order From Sup. of Doc., U.S. Government Printing Office, Washington, DC 20402. <input type="checkbox"/> Order From National Technical Information Service (NTIS), Springfield, VA, 22161		19. SECURITY CLASS (THIS REPORT) UNCLASSIFIED	21. NO. OF PRINTED PAGES
		20. SECURITY CLASS (THIS PAGE) UNCLASSIFIED	22. Price

An Investigation of the Miyagi-ken-oki, Japan, Earthquake of June 12, 1978

Issued under the auspices of the United States—Japan Program
in Natural Resources (UJNR) Panel on Wind and Seismic Effects

Bruce R. Ellingwood, Editor

Center for Building Technology
National Engineering Laboratory
National Bureau of Standards
Washington, DC 20234

Contributing authors:

A. Gerald Brady, U.S. Geological Survey, Menlo Park, CA
James D. Cooper, Federal Highway Administration, Washington, DC
Bruce R. Ellingwood, National Bureau of Standards, Washington, DC
Hugh H. Fowler, Federal Emergency Management Agency, Bethell, WA
Edwin L. Harp, U.S. Geological Survey, Menlo Park, CA
David K. Keefer, U.S. Geological Survey, Menlo Park, CA
Carl M. Wentworth, U.S. Geological Survey, Menlo Park, CA
Peter I. Yanev, URS/John A. Blume & Associates, San Francisco, CA

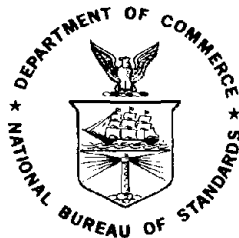

U.S. DEPARTMENT OF COMMERCE, Philip M. Klutznick, Secretary

Luther H. Hodges, Jr., Deputy Secretary

Jordan J. Baruch, Assistant Secretary for Productivity, Technology and Innovation

NATIONAL BUREAU OF STANDARDS, Ernest Ambler, Director

Issued October 1980

Library of Congress Catalog Card Number: 80-600116

National Bureau of Standards Special Publication 592

Nat. Bur. Stand. (U.S.), Spec. Publ. 592, 232 pages (Oct. 1980)

CODEN: XNBSAV

U.S. GOVERNMENT PRINTING OFFICE
WASHINGTON: 1980

FOREWORD

I am very pleased that a report on the investigation of the Miyagi-ken-oki, Japan earthquake of June 12, 1978, has been prepared by U.S. engineers and scientists as an activity of the joint program of the UJNR Panel on Wind and Seismic Effects.

I hope this report will play an important role not only in improving understanding of the Miyagi-ken-oki earthquake and other circumstances about earthquakes in Japan but also in contributing to the earthquake research of your country.

Through the field survey conducted by U.S. members at the sites where damage occurred from this earthquake, the importance of cooperating research activities in our panel was reaffirmed.

Finally, I deeply respect the effort to compile the report and hope our relationship will continue.

Yoshijiro Sakagami, Chairman (Japan)
UJNR Panel on Wind and Seismic Effects
Director General
Public Works Research Institute
Ministry of Construction

A part of the mission of the U.S.-Japan Panel on Wind and Seismic Effects of UJNR* is to carry out joint projects on the investigation of natural disasters. Immediately after the Miyagi-ken-oki, Japan earthquake of June 12, 1978, a team of U.S. panel members and other engineers and scientists was dispatched to Miyagi Prefecture. The investigation was coordinated by members of the Japan Panel on Wind and Seismic Effects.

This document is the result of the investigation by the U.S. team on the earthquake. It describes geologic features of the earthquake-stricken area, and damage to human-made structures. It is hoped the information presented in this document will add to the knowledge of seismology and earthquake engineering.

The U.S. Panel expresses its sincere appreciation to the Japan Panel for their cooperation in arranging the investigation and the fullest assistance given to the U.S. team. We look forward to the continuation of these cooperative efforts.

Edward O. Pfrang, Chairman (U.S.)
UJNR Panel on Wind and Seismic Effects
Center for Building Technology
National Bureau of Standards

* U.S.-Japan Cooperative Program in Natural Resources

ABSTRACT

On June 12, 1978, a destructive earthquake with Richter magnitude of 7.4 occurred off the east coast of Miyagi Prefecture, Japan. Preliminary estimates by the National Land Agency of Japan indicated that the earthquake caused an equivalent of \$800 million in total damage. There is a cooperative agreement between the governments of the United States and Japan termed the U.S.-Japan Program in Natural Resources (UJNR). Following the earthquake, it was arranged through UJNR that teams of U.S. structural engineers and geologists would visit Miyagi Prefecture and inspect the damage caused by the earthquake. This report assembles the information and collective experiences of the investigation team so as to describe the earthquake and document its effects. Field investigations conducted by geologists and structural engineers are described in detail and some of the implications for seismic resistant design and construction of structures in the United States are also discussed.

Key Words: Bridges; buildings; dikes; earthquakes; foreign engineering; geology; highways; housing; landslides; liquefaction; power plants; railroads; rockslides; seismicity; structural engineering.

Table of Contents

	<u>Page</u>
1. Introduction	1
1.1 General Situation	1
1.2 Acknowledgments	3
2. Social Effects and Government Response	4
2.1 Damage	4
2.2 Response	8
2.3 Reconstruction	10
2.4 Insurance	10
2.5 Conclusions	11
3. Tectonic and Geologic Setting	12
3.1 Introduction	12
3.2 Tectonic Setting	12
3.3 Seismic Gap and Precursors	19
3.4 Miyagi-ken-oki Earthquake of June 12	22
3.5 Location of Energy Source	25
3.6 Geology of the Damage Region	25
3.7 References	33
4. Strongmotion Records and Data	36
4.1 Introduction	36
4.2 The SMAC Accelerograph	36
4.3 Acceleration Records at Ground Level	37
4.4 Intensities	40
4.5 Records from Structures	43
4.6 A Comparison with Recorded Results of the San Fernando Earthquake 1971	47
4.7 Tohoku University Engineering Building	48
4.8 Tracing of Records	48
4.9 References	48
5. Earthquake Performance of Buildings	61
5.1 Introduction	61
5.2 Seismic Engineering and Construction Practice	61
5.3 Commercial and Retail Establishments	71
5.4 Schools	96
5.5 Residences	113
5.6 Summary	117
5.7 References	117
6. Effects to Industrial Facilities and Lifelines	120
6.1 Introduction	120
6.2 Fukushima Nuclear Power Plant Complex	120
6.3 New Sendai Power Plant, Tohoku Electric Power Company	123
6.4 Sendai Substation, Tohoku Electric Power Company	132
6.5 Haranomachi Plant of Sendai City Gas Bureau	137
6.6 Sendai Refinery, Tohoku Oil Co., Ltd.	137
6.7 Concrete Batch Plant, Sendai	154

	<u>Page</u>
7. Earthquake Performance of Transportation Lifelines	158
7.1 Introduction	158
7.2 Bridge Design Criteria	158
7.3 Bridge Damage	159
7.4 Highway Damage	186
7.5 Railroad Damage	186
7.6 Tunnel Performance	190
7.7 Conclusion	190
7.8 References	190
8. Liquefaction and Damage to Dikes	195
8.1 Introduction	195
8.2 Summary of Dike Damage	195
8.3 Geologic Setting	195
8.4 Field Observations of Dike Damage	198
8.5 Liquefaction in the Port of Ishinomaki	206
8.6 Conclusion	206
8.7 References	206
9. Seismic-Induced Landslides	209
9.1 Introduction	209
9.2 Rock falls and Rock slides in Natural Slopes	209
9.3 Rock falls and Rock slides in Cut Slopes	213
9.4 Landslides in Artificial Fill	219
9.5 Summary of Findings	223
9.6 References	223
10. General Conclusions	224

1. INTRODUCTION

1.1 GENERAL SITUATION

Sendai City, located in Miyagi Prefecture, Japan, is a modern industrial and commercial city located some 350 km northeast of Tokyo (Figure 1.1). Miyagi Prefecture has a population of about 1.9 million, of which approximately 600,000 reside in Sendai City. Another million are found in the suburbs of Sendai or in nearby cities and villages. This section of Japan is quite mountainous, and the population is restricted to coastal plains and mountain valleys. The population density is much more concentrated than in the United States. For instance, Sendai City occupies an area that is probably about one-third the size of Seattle, Washington, which has a similar population. There are about 6,500 business/manufacturing firms in Miyagi Prefecture and about 452,000 households (homes and apartments). Critical facilities within the area of damage include police, fire, power plants (nuclear and fossil fuel), oil and gas processing and storage, dams, hospitals, schools, and prefectural and municipal buildings.

On Monday, June 12, 1978, at 1714 hours local time, a destructive earthquake with Richter magnitude of 7.4 occurred off the east coast of Miyagi Prefecture. The earthquake hypocenter was located at 38° 9'N latitude, 142° 13'E longitude, at a depth of 30 km. This places the epicenter at a point approximately 120 km ESE from Sendai City and 95 km SE of the fishing town of Ishinomaki. The distance to the nearest instrumented recordings is about 70 km. Historically, this is a seismically active area; in fact, an earthquake of Richter magnitude 6.7 occurred as recently as February 20, 1978. Although the effects were felt as far away as Tokyo, where a window fell from a new high-rise building, major damage was confined primarily to Miyagi Prefecture. The intensity of ground shaking was reported to be V on the Japan Meteorological Agency (JMA) scale in an area approximately 180 km by 60 km along the coast which includes the cities of Ofunato, Ishinomaki, Shiogama, Sendai, and Fukushima. JMA intensity V is approximately equivalent to a Modified Mercalli intensity in the range VII-VIII. It is partially described as "Very strong - cracks in walls, overturning of tombstones and stone lanterns; damage to masonry chimneys and mud-plastered warehouses." The main earthquake was preceded by a smaller shock at 1703 hours; several aftershocks were felt during the following 4 days.

As of July 1, 1978, 27 deaths had been attributed to the earthquake in Miyagi Prefecture, of which 17 were caused by collapsing walls; nearly 1,600 people were injured. Electrical power was lost in Sendai for approximately 6 hours, and was not completely restored for several days. Damage to the natural gas distribution system upon which much of the city relies was a significant problem, and some areas of Sendai were still without gas 2 weeks following the earthquake. Other critical services were disrupted, but not to the extent that disaster recovery operations could not begin immediately following the earthquake. Preliminary estimates by the National Land Agency indicate that the earthquake caused an equivalent of about \$800 million in total damage.

There exists, between the Governments of the United States and Japan, a cooperative agreement termed the U.S.-Japan Program in Natural Resources (UJNR). The principals for the UJNR Panel on Wind and Seismic Effects are the U.S. National Bureau of Standards (NBS) and the Public Works Research Institute (PWRI) of the Japanese Ministry of Construction. Other Government agencies are also involved in the program, including the U.S. Geological Survey and Federal Highway Administration on the U.S. panel and the Building Research Institute and the National Research Center for Disaster Prevention on the Japanese panel. Following the earthquake, it was arranged through UJNR that teams of U.S. structural engineers and geologists should visit Miyagi Prefecture and inspect the damage. Concurrently, the Federal Disaster Assistance Administration arranged for the visit of their representative through the American Embassy in Tokyo.

Team members traveled as individuals or as groups as their interests and circumstances dictated. Mr. Brady arrived June 19th and spent 2 days in the Sendai area viewing general damage. Messrs. Cooper, Ellingwood, and Yaney arrived on June 22nd and spent 5 days in Miyagi Prefecture inspecting damage to buildings, industrial facilities, and transportation structures. Messrs. Harp, Keefer, and Wentworth arrived on June 23rd; their primary interests were in geology, seismicity, liquefaction and dike damage, and landslides and rock falls. Mr. Fowler arrived on June 24th to investigate the social effects of the earthquake and how the Japanese authorities responded to the disaster.

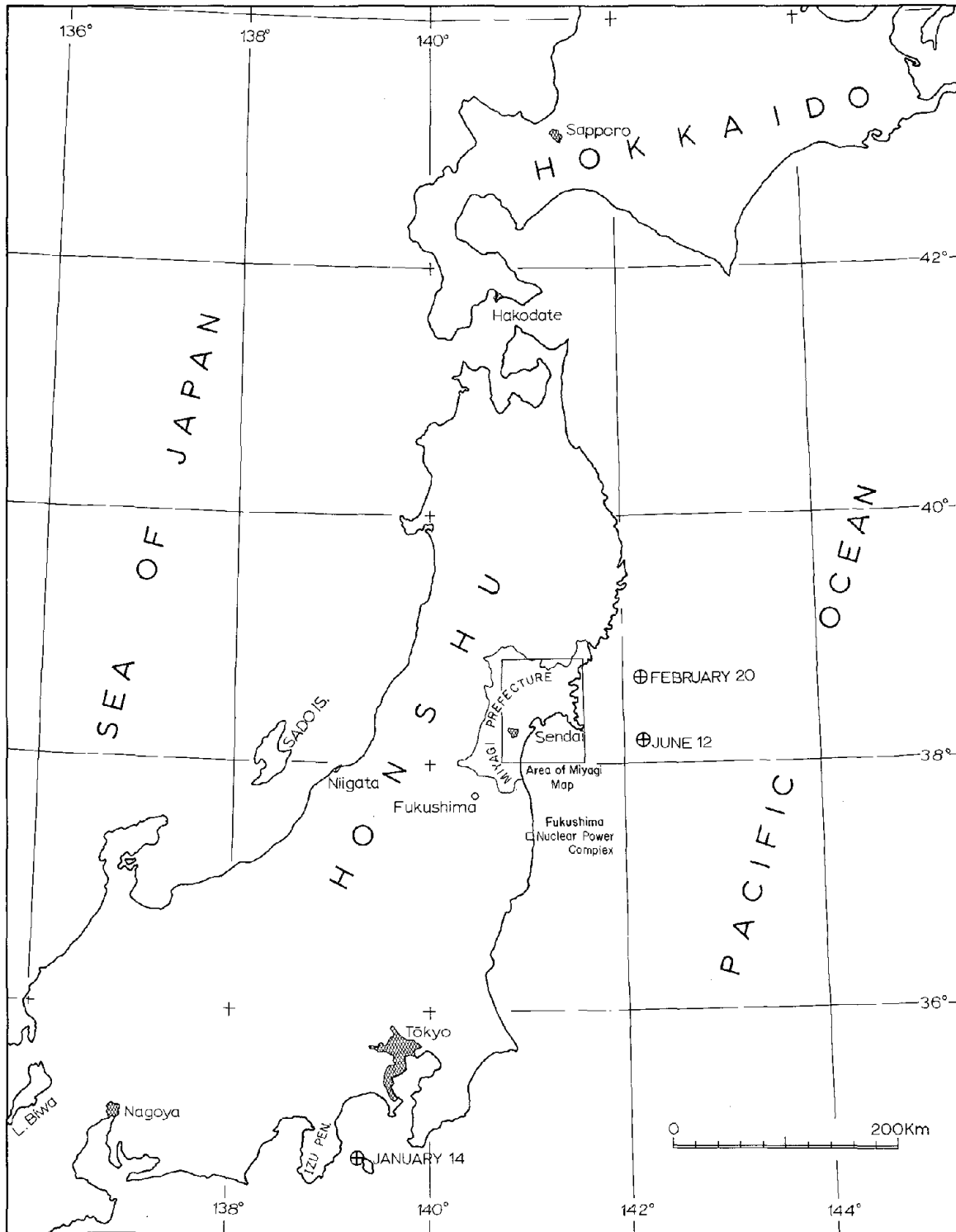

Figure 1.1 Map of Japan showing locations of Miyagi Prefecture, Sendai City and epicenters of 1978 earthquakes.

The purpose of this report is to assemble the information and collective experiences of the team members so as to describe the earthquake and document its effects. The field investigations conducted by geologists and structural engineers are described in detail, and some of the implications for the seismic resistant design and construction of structures in the United States are discussed.

1.2 Acknowledgments

The investigation of the Off-Miyagi earthquake would not have been possible without the assistance of numerous Japanese engineers, geologists, and Government officials who handled logistics and provided U.S. team members with unpublished data. Thanks first of all are due to Mr. Kazuto Nakazawa, former Director-General of the Public Works Research (PWRI) and former Chairman of the Japan panel of UJNR, for enabling us to work with his staff at a very busy and inopportune time for them. In particular, Dr. Tadayoshi Okubo, former Director of the Planning and Research Administration Division within PWRI and now Assistant Director-General, who also served as secretary for the Japan Panel of UJNR, arranged itineraries, made travel arrangements within Japan, arranged meetings with Japanese engineers and geologists, and facilitated entrance to sites of damage that otherwise would have been inaccessible. Mr. Toshio Iwasaki, Head of the Ground Vibration Division in PWRI, accompanied Messrs. Cooper, Ellingwood and Yanev on their field investigation trip to Fukushima, Sendai and Ishinomaki, while Dr. Masamitsu Ohashi, former Director of the Earthquake Disaster Prevention Department of PWRI, accompanied Mr. Brady for 2 days. Mr. Toyokazu Shimizu of the Tohoku Regional Construction Bureau spent 2 days escorting team members to sites of damaged buildings in Sendai City while Mr. Kunimatsu Hoshihata of the same Bureau hosted the visit to Ishinomaki. Representatives from the U.S. Geological Survey were hosted by Mr. Tadayuki Tazaki and were accompanied to Miyagi Prefecture by Mr. Eiichi Kuribayashi, both of the Earthquake Engineering Division, PWRI.

Dr. Hiroshi Tanaka of Tokyo Electric Power Company conducted the tour of the Fukushima power plant and later was available for discussions in Tokyo. Dr. Shinsuke Nakata of the Structural Engineering Division, Building Research Institute, was available for discussion on damage to building structures following our return to Tokyo. Mr. Hajime Tsuchida of the Port and Harbour Research Institute made some of the strong motion records available to the team and provided information on damage in the port of Ishinomaki.

In addition to those already mentioned, acknowledgments are due Mr. Keiichi Ohtani of the National Research Center for Disaster Prevention, Science, and Technology Agency; Messrs. Haruo Yoshikoshi and Yasou Watanabe of the Sendai Construction Office, Ministry of Construction; Mr. Shigeyoshi Shima, Tohoku Regional Construction Bureau, Ministry of Construction, Messrs. Kunimatsu Hoshihata, Chutarō Chiba and Tsuyoshi Soto of the Kitakami-Karyu Construction Office, Ministry of Construction; Mr. Kazuhiko Kawashima of PWRI; Messrs. Nagahisa Ikuta, Masaki Takahashi and Osamu Yotsuyanagi of the National Land Agency; Messrs. Hidenao Miyamoto and Toshio Shono of Tohoku Petroleum Co., Ltd., Mr. Chunchiro Kiowa of the City of Sendai; Messrs. Masashige Sasaki, Tokashi Shibuya, Yokio Matsuzaki and Akira Tokano of Miyagi Prefecture; and Professors Akio Takagi, Ishii, Hisao Nakagawa, Akenori Shibata and Toshio Shiga of Tohoku University; Messrs. Takashi Hirai, Yoichi Fujii, and Noboru Inouchi of the Geographical Survey Institute in Tokyo.

On the U.S. side, Drs. Edward O. Pfrang and H. S. Lew of NBS, chairman and secretary, respectively, of the U.S. Panel of UJNR, made the initial arrangements which were necessary to facilitate the visit of the U.S. structural engineers to Miyagi Prefecture. Mr. Yanev's visit was supported, in part, by the Earthquake Engineering Research Institute. Mr. Louis Cattaneo of the National Bureau of Standards assisted in assembling the material for this report. Mr. Justin L. Bloom, Counselor for Scientific and Technological Affairs of the U.S. Embassy and his assistant, Mr. Bruce Carter assisted Mr. Fowler in his visit.

2. SOCIAL EFFECTS AND GOVERNMENT RESPONSE*

2.1 DAMAGE

There are about 6,500 business and manufacturing firms and about 452,000 households (homes and apartments) in Miyagi Prefecture. In Miyagi Prefecture, 803 dwellings were destroyed (309 in Sendai). Major causes of the destruction were landslides, inadequate foundations, and inadequate lateral bracing. A number of 2- to 4-story apartment buildings were rendered uninhabitable when their first-floors, housing shops or parking space, collapsed.

According to data compiled by the National Land Agency, the earthquake caused damage amounting to 166 billion yen (\$830 million). A detailed outline of the various types of damage and the economic loss that resulted is presented at the end of this chapter. In some cases the amounts listed represent the cost of replacing a building or facility with a modern structure even though the damage caused by the earthquake could be repaired at a lower cost. Almost half of the total damage estimate represents the cost of repairing or replacing factories, stores, and other business establishments as shown in Table 2.1.

Most buildings in Japan have tile roofs. Literally thousands were damaged; this was the most apparent type of damage in the area. (Tile falling from roofs caused a number of injuries.) Item 9 of the damage indicates that 20,634 structures were flooded. Sendai City and Miyagi Prefecture officials reported that four homes were flooded as a direct result of the earthquake. Because of the extensive roof damage, and because the area received heavy rains after June 12, it may be that secondary water damage is reflected in the table.

In considering the damage, one must understand the topography and construction siting areas in and near Sendai. Sendai has three distinct areas: the old (original) city, which is centrally situated on solid level ground; a new section on the eastern side, toward the coast, much of which is constructed on soft, flat ground (some of which includes fill areas); and an area of hills to the north and west, where people have constructed homes and buildings on terraces. Damage and losses were much greater in the soft and hill areas than in the old section.

In the hill areas, unstable fill surfaces in combination with saturated soil caused many landslides. Cracks, mostly associated with the landslides, formed in the terraced ground where houses and apartment buildings were built. According to officials, a total of 337 landslides occurred throughout the prefecture.

Liquefaction in conjunction with inadequate foundations contributed to heavy damage in the flat (soft) area. Reports of dike and levee subsidence were verified in many areas along streams. At Nokahura, which is near Sendai, a dike that was originally 7 to 8 m high settled 1.5 m because of liquefaction.

Reinforced concrete buildings, bridge piers, and bridge abutments settled and sustained damage in many areas due to liquefaction and inadequate footings. Soft soil layers under reinforced concrete structures contributed to much of the damage. It is interesting to note that damage to buildings from north-south shaking motion was often noticeably more severe and extensive than damage from east-west movement. Steel-frame buildings by and large survived the earthquake better than reinforced concrete structures. Some lost facades and windows, and only one collapsed. Older buildings constructed of wood frames were damaged because of inadequate lateral bracing.

A major oil refinery in the port area of Sendai, containing 98 storage tanks of varying sizes, suffered damage when three large tanks containing fuel oil sprang leaks. Several million gallons of oil flooded the refinery area, and some reached the waterway serving the port.

The major cause of deaths and injuries from the earthquake was collapsing or falling walls made of stone or cinderblock. These structures serve as fences, privacy walls, and noise barriers. There is a National Code that requires that walls of this kind that are over

* Prepared by Hugh H. Fowler, Emergency Management Agency, Bothell, Washington.

Table 2.1 Outline of Preliminary Damage from June 12, 1978, Miyagi-ken-oki Earthquake

	<u>Quantity</u>	<u>Value (million \$)</u>
1. Dead	27	--
2. Missing	0	--
3. Injured	1,052	--
4. Households suffering damage	3,477	--
5. Individuals suffering damage	13,768	--
6. Buildings wholly destroyed or burned or washed away	803	--
7. Partially destroyed buildings	5,227	108.7
8. Partially damaged buildings	58,927	--
9. Flooded building	20,634	31.0
Subtotal		139.0
10. Hospitals	119	1.7
11. Clinics	194	0.2
12. Medical equipment	735	1.0
13. Water Works	--	4.8
14. Sanitation facilities	29	5.3
15. Other sanitation facilities	33	7.4
Subtotal		20.4
16. Factories and stores	55,078	455.0
17. Other business establishments		
Subtotal		455.0
18. Paddy fields (ha)	5.5	0.3
19. Fields or farms (ha)	--	--
20. Agricultural facilities	535	24.1
Subtotal		24.5
21. Farm produce (ha)	541.1	1.1
22. Joint-use facilities	424	5.8
Subtotal		6.9
23. Livestock	2,100	--
24. Livestock facilities	35	0.6
25. Livestock products	3	--
Subtotal		0.6
26. Sericultural (silkworm) facilities	12	--
27. Fishing boats	17	--
28. Fishing port facilities	109	13.5
29. Fishery and aquaculture facilities	341	5.0
30. Fishery products	--	0.2
31. Fishing equipment	64	--
Subtotal		18.9
32. Forest land, roads	56	1.6
33. Forestry facilities	38	0.9
34. Forestry products	6	0.1
Subtotal		2.6
35. Primary schools	367	7.0
36. Middle schools	170	2.1
37. High schools	102	7.0
38. Other schools	323	14.7
39. Cultural assets	22	1.2
Subtotal		33.2
40. Roads (sites of damage)	720	16.8
41. Bridges	65	32.1
42. Rivers (sites of damage)	115	6.6
43. Shores	5	1.1
44. Erosion control facilities	12	1.7
45. Ports and harbors	85	7.6
Subtotal		66.0
46. Railways	--	34.8
47. Electrical facilities	--	13.7
48. Communications facilities (sites of damage)	2,660	2.3

	<u>Quantity</u>	<u>Value</u> (million \$)
49. Social welfare facilities	166	3.0
50. Urban facilities	76	4.1
51. Gas facilities	53	2.0
52. Other facilities	231	3.1
Subtotal		62.8
Total loss		830.0
Number of people evacuated by order or recommendation	26,017	
Number of communities where headquarters for disaster countermeasures were set up	56	

1-1/2 m high must be reinforced in both directions with steel bars. (The bars must be at least 9 mm in diameter and must consist of an 80 cm grid across and down the wall.) Some of the walls that fell contained inadequate reinforcing and were more of a danger than those with none: those with no reinforcement tended to crumble, while those with inadequate reinforcing toppled on people who were nearby or who held onto them for stability as the earthquake occurred.

2.1.1 Public Facilities, Services, and Lifelines

Effects of the earthquake on so-called critical facilities, on public services, and on other vital activities were varied. In some cases, functioning was interrupted only temporarily, in other cases, the impact on segments of the population lasted for several weeks.

2.1.2 Law Enforcement and Emergency Services

Only slight damage was sustained by police facilities. The police communication system played a vital role in maintaining order and dispersing factual information immediately after the earthquake. Fire service facilities, also, received little damage, and units had no difficulty coping with the few (10) fires that started.

Of the 41 hospitals in the Prefecture (27 in Sendai), several sustained varying amounts of damage. The natural gas and electricity outage interfered with medical services. However, there were no reported problems with overloading because of the influx of injured to the city for treatment.

2.1.3 Transportation

The National Railway stopped all train service in the area immediately after the earthquake to insure against accidents and to assess damage to the system. Service was restored quite soon after repairs were made, and the safety of the line and its control systems was ascertained. Public bus service in Sendai was hampered in the hours immediately following the earthquake because of traffic light failure. Air service between Sendai and other points was quickly restored after airport officials assessed damage and found that safe service could commence.

2.1.4 Utilities

Damage to the natural gas distribution system in Miyagi Prefecture was a major recovery problem. Gas distribution systems in six cities were severely affected. About 60% of the 200,000 households in Sendai are dependent on gas for heating and cooking. As of June 28, 1978, 22,000 of those households as well as 10,419 households in other cities of the prefecture were still without gas.

Electrical service to 419,100 homes in the prefecture was interrupted. For the most part, service was restored within a day or two. Few distribution line poles were toppled. Two electrical generating plants serving Sendai were out of operation. One of those plants, located near the oil refinery at the port, depended upon fuel from the one refinery that was rendered inoperative. The other, located in north Sendai, was rendered inoperative when the city's storage plant for low-pressure gas caught fire and service had to be terminated. Electrical power from other areas and facilities was diverted and at the time of the reconnaissance was meeting the needs of Sendai, although several factories in the prefecture were still without power.

Within the prefecture, there are about 50 separate water and sewage conveyance systems, most of which are publicly owned. Prefecture officials estimated the damage to these systems, all of which had been restored by June 25, 1978, at about \$30,000,000. Several lift station pumps had to be replaced. Damage to sewer lines in Sendai was minimal, however, until electricity had been restored, the system was partially inoperative. Several nuclear electrical generating plants are located near Miyagi Prefecture. It is interesting to note that none experienced any significant earthquake-related problems or damage.

2.1.5 Communications

All telephone service in Sendai and in the surrounding areas was interrupted from 5:14 p.m. until 8:00 p.m. on June 12, 1978. By 8:00 p.m., 50% of the service in the Sendai area and 75% of the service in areas north of Tokyo had been restored. The disruption extended as far south as Tokyo.

With the loss of electricity, all television and radio stations were unable to broadcast. Several came back on the air soon afterwards by using emergency generators and performed an important service by broadcasting factual information provided by the police and local government officials. However, because most of the population was without electrical service, only those people with battery-operated transistor radios could receive emergency information. (No formal emergency broadcast system exists in Japan.)

2.2 RESPONSE

Immediately after the earthquake, government officials in Tokyo (national), in Sendai (prefecture and city), and in other communities met to take emergency-response action and to plan recovery measures. Sendai established a Disaster Countermeasures Headquarters headed by the mayor. Included in this group were representatives of the National Railway; water, gas, and electric utilities; the police and fire departments; the Red Cross; and others. This headquarters remained operational for 24 hours a day immediately after the earthquake. It was still in operation of June 27, 1978. Actual response activities are the City of Sendai's responsibility. If an emergency is beyond the means of their resources, City officials may request additional services or financial help from the prefecture or national government.

With regard to food and supplies and distribution of emergency rations, the Governor of the Prefecture activated a Headquarters for Self-Sufficiency for the purpose of monitoring food supplies and prices as well as to insure the availability of other items necessary for the populace to survive and recover. Among the tasks the Headquarters performed were:

- Checking on regional and central wholesale markets
- Checking on bread and dairy products
- Checking department and food stores
- Arranging for additional propane bottles and burners
- Monitoring the supply of electric cells (batteries) for flashlights
- Requesting cooperation from the sales industry to maintain stable prices (prices of some critical items actually were lowered during the emergency period)
- Receiving and considering consumer complaints
- Providing propane burners and fuel to handicapped centers
- Providing coordination with producers and suppliers of lumber, glass, concrete, and other building supplies to insure that adequate stocks were available where needed
- Coordinating with National Government officials in Tokyo when necessary.

The headquarters used the media to the fullest extent possible to broadcast factual information concerning supplies and prices. Close daily contact was maintained with 30 designated stores in the area to monitor events.

The police force played a key role in maintaining order and providing information to the populace. Because the lack of electric power limited the effectiveness of the mass media, police used loudspeakers on vehicles. By 8:30 p.m. on June 12, more than 7,000 people had gathered at the Sendai train station (all trains had stopped after the earthquake). The police moved in portable generators, set up lights, and used loudspeakers to provide infor-

mation. By keeping them informed about the likelihood of tsunami or another earthquake and about the damage situation, authorities were able to calm the public and avert panic. By 9:30 p.m., all but 600 of the crowd had dispersed.

A traffic control center was set up immediately after the earthquake to handle the severe traffic problem. Crowds of people and vehicles had gathered at crossings. To deal with this the following measures were taken:

- ° All available police were ordered to duty
- ° The traffic control center monitored critical areas and dispatched police to handle problems
- ° Loudspeakers were used effectively to inform the public.

The damage caused by the earthquake had been judged not great enough for the Prime Minister to issue a National State of Emergency declaration for the Miyagi Prefecture. Article 105 of the Disaster Countermeasures Basic Law provides the basis for issuance of such a declaration. Officials of the Ministry of Construction have visited Miyagi Prefecture to assess the damage caused by the earthquake. On the basis of their assessment, the National Government will determine the amount of national funds to be provided (usually two-thirds of the cost, with the remaining third to be borne by the prefecture).

Japan has a Disaster Relief Act, which is administered by the Ministry of Health and Welfare. Under this authority, which does not require a declaration by the Prime Minister of a National State of Emergency in order to act, relief was approved for two cities and four towns. Each municipality (or prefecture) submits a request, accompanied by data, photographs, and loss statistics to the National Government. Included as benefits under the Act are low interest loans (5.05%) to replace buildings of wood construction. The period of repayment can be extended to 25 years. Homeowners with existing loans on their property are not eligible for much assistance under the Disaster Relief Act other than a low-interest loan. This means that they would need to carry two loan payments, City of Sendai and Miyagi Prefecture officials are trying to get National funding to cover the initial load balance.

The prefecture disaster plan provides that local government heads can request military support and assistance (from the Self-Defense Force). Between June 12 and June 19, such help was requested by the provided to six cities and seven towns. A total of 2,117 military personnel were involved in supplying water to people in areas where normal systems were not operative. They were also instrumental in saving three lives.

Two factors influenced the need for evacuation: the danger of a Tsunami and the unsafe conditions caused by the earthquake damage.

A Tsunami warning was issued at 5:21 p.m. on June 12. The actual order to evacuate must be given by a Mayor or head of government. The Sendai Mayor did not order an evacuation but did issue a warning. Local officials in other coastal communities did issue evacuation orders, and more than 20,000 people moved inland. The "all clear" was received at 8:15 p.m., and those who had left their homes were permitted to return.

Evacuation was necessary to protect people whose homes had been destroyed or judged unsafe for habitation. Approximately 70 families were ordered from their homes in the hill areas of Sendai because of continuing danger of landslides.

Most displaced, evacuated individuals and families stayed with relatives and friends. However, the city and prefecture response plans provide for the use of schools, hospitals, and other public buildings as shelters. Under extreme conditions, the National Defense Force can provide tents or other types of shelter for transient population.

Little search-and-rescue activity was associated with the earthquake. Life-saving measures were performed as necessary by fire and police forces working in the Fire Defense Headquarters, established in affected municipalities immediately after the quake. Two apartment buildings were involved when their first floors collapsed, and evacuation of the occupants of other floors required the assistance of fire departments. The National Self-Defense

Force assisted in locating the body of a missing person. Two other bodies were recovered by neighborhood groups.

The City of Sendai has five rescue teams on alert at all times. When the earthquake occurred and electrical power was lost, the traffic signal system (there are more than 400 signals in the city) became inoperative. Major traffic congestion developed at most intersections, and ambulances were able to respond to only 24 of the more than 200 calls for aid. A central emergency facility, where people could obtain medical treatment, was quickly established in Sendai. Hospitals activated an emergency medical information center, which consisted of computerized data on doctors, hospital bed space, ambulances, etc.

On June 25, only 705 people (in three cities and nine towns) remained in shelters. Sites used for shelters included school gymnasiums, citizens halls, and other public facilities. Emergency rations were distributed by volunteer agencies. The Japanese Red Cross was not asked to participate in the emergency-response or recovery phases of this disaster.

Because both gas and electricity were lacking in many homes, people bought food that did not require cooking. Stores received additional quantities of precooked foods from areas not affected by the earthquake. Fortunately, most grocery stores and markets in the area remained intact, and there was ready access for shopping. Food prices remained stable despite the heavy demand for particular types of food. Because most homes depend upon gas for cooking and heating, the Sendai Gas Company (public) distributed portable gas heaters for purchase at less than cost.

More than 300 homes in Sendai were destroyed. Under certain conditions, the local and prefectural governments may construct prefabricated dwellings for those who lose their homes.

Approximately 70 such dwellings were under construction in Sendai to provide shelter to those who did not have other means.

Neither the City of Sendai nor Miyagi Prefecture attempted to establish or maintain a locator service for missing persons. As soon as the radio and television stations resumed service, selected stations set aside an hour each day to broadcast names and messages. The telephone company also liberalized its use of phones to assist victims.

2.3 RECONSTRUCTION

New construction in Japan must conform with the Architectural Law, which contains special requirements to mitigate earthquake damage and is administered by the Ministry of Construction. Builders must submit plans to prefectural or larger municipal governments for review and approval before starting construction. With very few exceptions, buildings destroyed or seriously damaged had been constructed before the law was in effect.

The Sendai City and Miyagi Prefecture government formed a Reconstruction Planning Committee to ensure that building replacement and repair will contribute toward safety. The committee includes representatives of higher education institutions, commercial and business concerns, industry, and the architectural profession. The Sendai Construction Bureau will insure that new construction in the city meets the requirements of the National Building Code.

2.4 INSURANCE

2.4.1 Unemployment Insurance

Although manufacturing firms and business were hard hit by the earthquake, a large majority of those whose jobs were affected were back at work soon after the earthquake. Some manufacturers who were operating on a marginal basis had not reopened at the time of the reconnaissance; the workers affected were drawing unemployment insurance.

2.4.2 Earthquake Insurance

There are at least two types of earthquake insurance available in Japan. Both are expensive.

One type of protection, available to a farmers association, covers 100% of the damage up to a maximum of 25,000,000 yen. Lesser amounts of coverage can be obtained.

The other (major) type of earthquake insurance, is a plan that is endorsed and guaranteed by the government. This program was initiated five years ago but has not met with general acceptance. What appear to be major limitations are its high cost and the limitations on coverage. The maximum coverage for goods is 1.5 million yen (\$7,500); the maximum coverage for homes is 2.4 million yen (\$12,000). (The average home in Japan cost 15 to 20 million yen.) Both city and prefecture officials in Sendai stated they felt that there is a need to equalize the program. It was their consensus that the insurance program will become popular if coverage can be increased and rates adjusted. This type of insurance is required of those who request and receive low-interest disaster-relief loans.

2.5 CONCLUSIONS

The 1977 Disaster Countermeasures Act of Japan, administered by the National Land Agency, requires that each level of government have a plan and a competent organization for dealing with disasters. The rapid and effective response by all levels of government (national, prefectural, and municipal) towards alleviating the affects of the earthquake was the result of a unified, integrated program of disaster preparedness and response.

The amount of recovery work accomplished or under way within two weeks after the earthquake occurred was impressive. The speed and efficiency with which a vast amount of work had been performed was most admirable. Officials responsible for directing operations and others working to accomplish the monumental task of recovery exhibited unusual industry and knowledge about the problems they faced and how to solve them. All, without exception, devoted their efforts exclusively to serving the needs of the people and communities that were adversely affected.

3. TECTONIC AND GEOLOGIC SETTING*

3.1 INTRODUCTION

The Miyagi-ken-oki earthquake of June 12, 1978 occurred in the outer zone of seismicity in Japan, along the subduction zone that bounds the east side of northeast Honshu. This was only one of the many damaging earthquakes that Japan experiences because of its active tectonic setting, and the third in 1978. Most of the larger earthquakes are directly associated with the subduction zone along which the margin of the westward drifting lithosphere under the Pacific Ocean is plunging beneath Japan at a long-term rate of about 10 cm per year. The area where damage occurred in the June 12 earthquake lies on the east coast of northeast Honshu about 300 km north of Tokyo, in a region of low, flat alluvial plains, local alluvial terraces, and steep bedrock terrain of largely moderate relief.

This chapter describes the Miyagi-ken-oki earthquake and its setting as background for the more detailed reports on the effects of the earthquake. The tectonic setting of the earthquake is described, together with the reason that a larger earthquake following the June 12 event was (and still is) a serious, although uncertain, possibility. The June earthquake and its pattern of aftershocks are described, and this pattern is used to illustrate the important distinction between epicentral and fault distance in attenuation studies. Finally, the geology of the affected region is summarized, because of its influence on the distribution, character, and severity of earthquake damage.

This chapter is based on the literature (in English) available in Menlo Park, and on information gained from discussions with, and documents and maps provided by, Japanese officials and scientists during the author's visit to Japan as a U.S. Geological Survey representative on the U.S. team in June 1978. The information is necessarily incomplete because only two weeks had been available for study of the earthquake by the Japanese at the time of the visit to Japan by the U.S. team, and time for discussion and observation during the visit was brief. More thorough accounts will undoubtedly result from the Japanese studies.

3.2 TECTONIC SETTING

Japan is located along the leading overthrust margin of Asia against subducting sea floor of the Pacific plate (inset, Figure 3.1). That plate is drifting northwestward toward the nearly stationary Asian continent, as recorded over the past 40 million years by the Hawaiian chain of volcanoes strung out northwest of the eruptive source now beneath Hawaii. The subduction zone beneath northeast Honshu is marked at the surface by the Japan deep-sea trench and associated island arc, one of several extending around the perimeter of the northwest Pacific (Aleutian, Kurile, Northeast Honshu, Izu-Bonin, and Mariana arcs).

The northeast Honshu arc system consists of a concentric sequence of tectonic elements (Figures 3.1 and 3.2): from east to west, (a) the subducting oceanic plate and deep-sea trench, (b) a submerged forearc terrane consisting largely of the inner-trench slope and a broad deep-sea terrace underlain by more than 2 km of Tertiary sediments, (c) the emergent frontal arc, (d) a volcanic chain atop the front of (e) a deformed backarc geosyncline, and (f) a backarc basin. Most of the arc system is underlain by ancient continental basement, which is bounded on the east and west by thinner oceanic crust, on the east by the Pacific plate, and on the west by the crust of the backarc basin, formed during the early Tertiary opening of the sea of Japan.

This pattern of tectonic features concentric with the Japan trench was established about 25 million years ago, when the Mizuho orogeny began in northeast Honshu with block faulting, subsidence, and extensive volcanism west of the Morioka-Shirakawa tectonic line (Figure 3.1). The Miocene faults broke obliquely across the older north-northwesterly trending structure, such as the Tanakura tectonic line (Figure 3.2). The present tectonic regime is a later phase of that orogeny, in which Quaternary compressional deformation marked by northeast-trending reverse faults and overturned folds has supplanted the earlier extensional regime.

* Prepared by Carl Wentworth, U.S. Geological Survey, Menlo Park, California

Explanation of Symbols for Figure 3.1

- Qs Quaternary sediments, consisting of alluvium, terrace deposits and lake beds
- N Neogene sediments and Cenozoic volcanics, including the extensive Early Miocene green tuff, folded younger sediments, and Quaternary volcanics
- pN Pre-Neogene rocks, including Paleogene and Mesozoic rocks, metamorphic rocks, and Cretaceous or older plutonic rocks; exposed rocks as old as Silurian are recognized. Abukuma block largely plutonic rocks; Kitakami block largely late Paleozoic and early Mesozoic metasediments and scattered plutonic masses
- △ Active volcano
- Morioka-Shirakawa tectonic line (MSTL, approximate location) and the boundary in early Miocene rocks between thick, mainly marine, altered tuff (the green tuff) on the west and thin, mainly terrestrial volcanic rocks on the east
- Contact, dashed offshore where location very approximate, dotted along limits of information offshore
- Major fault, including the Itoigawa-Shizuoka tectonic line (ISTL) along the west margin of the Fossa Magna zone of deformation and low topography, the Median tectonic line (MTL) of Southwest Japan, and the Tanakura tectonic line (TTL). Dashed where approximately located; dotted where concealed
- ==== Quaternary fault, longer than 10 km, which offsets or deforms late Pliocene or Quaternary deposits
- ▲▲▲ Arc (inset): A - Aleutian; K Kurile; H - Northeast Honshu; I-B - Izu-Bonin; M - Mariana. Teeth on upper plate

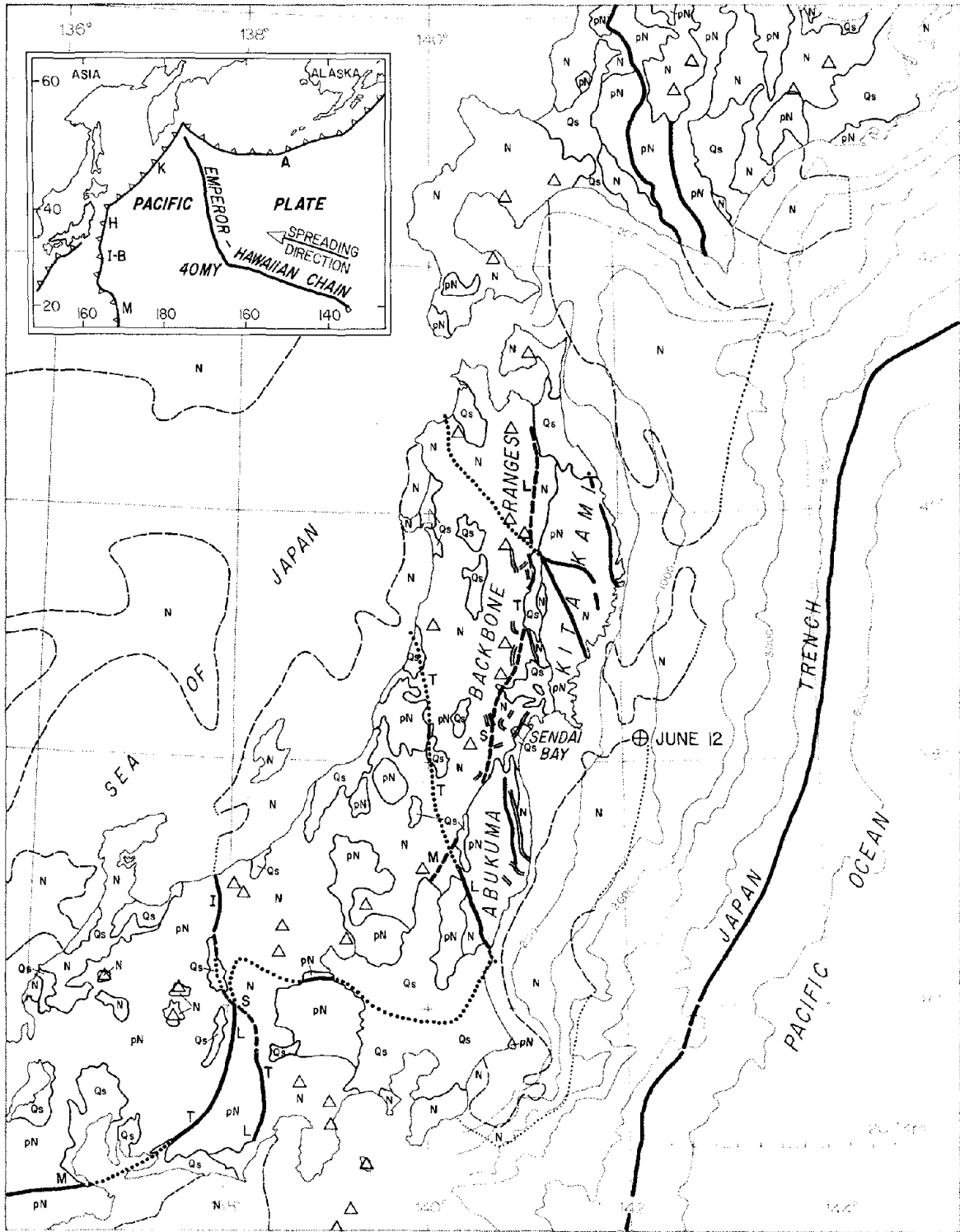

Figure 3.1 Geologic map of northeast Honshu region and plate tectonic setting, compiled from Dickinson (1979), Geological Survey of Japan (1964), Ishiwada and Ogawa (1976), Isomi (1968), Research Group for Quaternary Tectonic Map of Japan (1969), and Yoshida (1975).

Explanation of Symbols for Figure 3.2

Qu	Quaternary volcanic rocks
Qs	Quaternary sediments
N	Neogene sediments and volcanic rocks
Pe	Paleogene sediments
Mz	Mesozoic rocks
Pz	Paleozoic rocks
b	Basement rocks (pre-Silurian)
a	Accretionary wedge - deformed sediment presumably scraped from oceanic plate during subduction
-----	Envelope of seismicity along and above top of subducting slab, from Figure 3.4
∅	Location of hypocenter and apparent dip of focal mechanism for June 12, 1978 earthquake
—————	Approximate extent of June 12 fault rupture in section
6.1	Seismic velocity in km/s

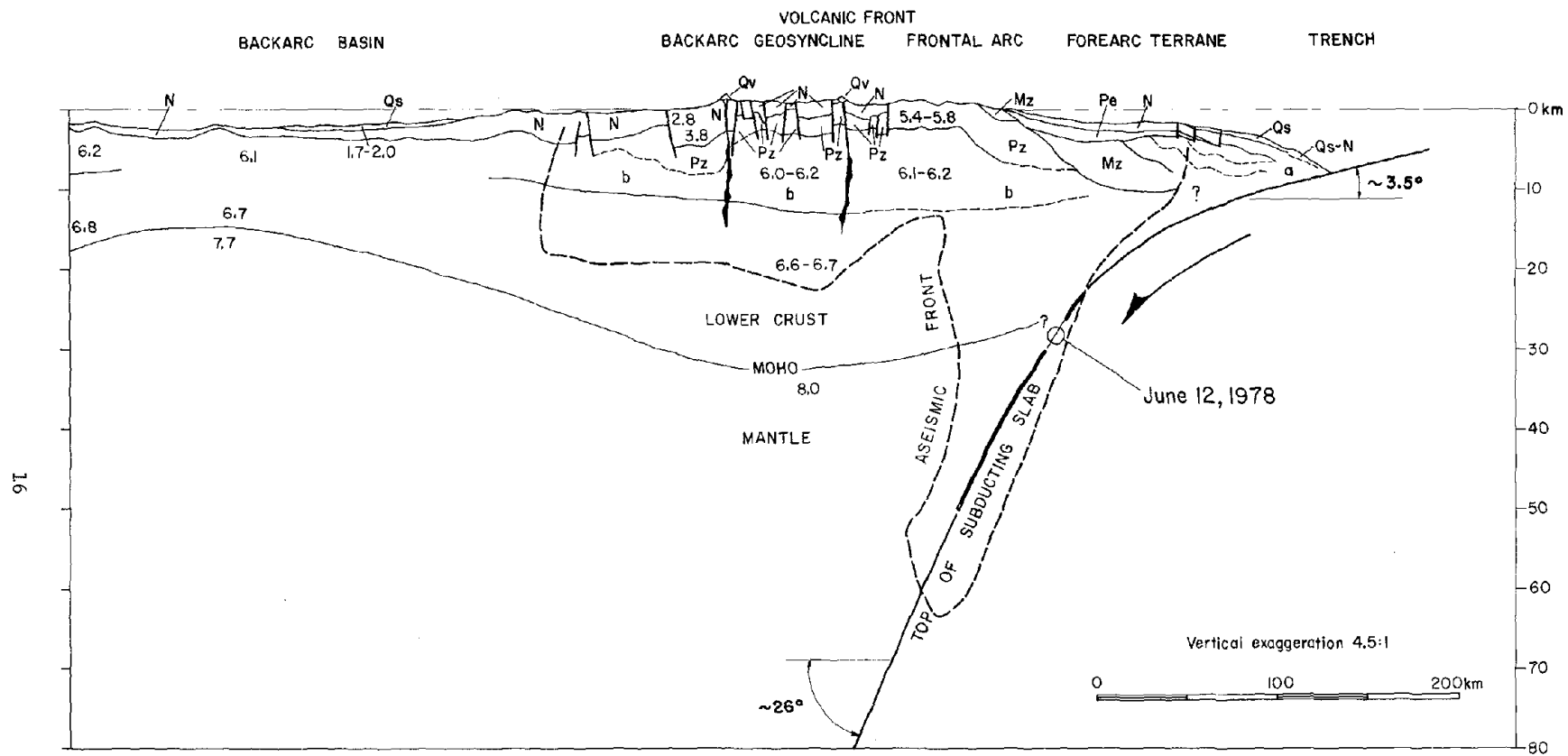

Figure 3.2 Schematic cross sections of Northeast Honshu arc. Drawn along an east-west profile through the Kitakami block, with information spliced from figure 18 of Kitamura and Onuki (1973), figure 1 of Von Huene, Nasu, and others (1978), and figure 6 of Takagi and other (1977). Locations of trench, eastern shoreline, and volcanic front used to register source sections.

The known reverse faults in northeast Honshu are short, scattered, and few relative to the numerous Quaternary faults of varied style in central Honshu and the 800-km-long strike-slip fault along the Median tectonic line in southeast Honshu (Matsuda, 1977). Most of the faults occur along and west of the Morioka-Shirakawa tectonic line and in the Sendai region between the Abukuma and Kitakami structural blocks. Some of these faults have undergone quite recent movement, but apparently none were involved in the June 12 event.

Most of the present relief in northeastern Honshu has formed during this Quaternary compressional phase of the Mizuho orogeny. Beginning 1 to 3 million years ago, the average rate of the vertical movements that accomplished these changes increased tenfold to the order of 1 to 10 mm/yr (Matsuda, 1976). Concurrently, renewed volcanism built the modern volcanoes aligned just west of the frontal arc.

This third and current phase of the Mizuho orogeny, following the initial volcanism and development of the backarc geosyncline and its subsequent breakup and gradual uplift, suggests some change in the subduction regime that drives the system. One possibility is a change in subduction rate. Based on study of the ages and positions of volcanoes in the Emperor-Hawaiian chain, Shaw, Jackson, and Bargar (1979) suggest that a threefold increase in the rate of west-northwestward drift of the Pacific plate relative to the magma source occurred about 1.3 million years ago.

Modern seismicity indicates that subductive underthrusting continues along the northwest Pacific island arcs. The regularity of great thrust earthquakes in space and time that characterizes the Aleutian and Kurile arcs decreases along the northeast Honshu arc, however, and such earthquakes appear to be lacking along the Izu-Bonin and Mariana arcs to the south. The degree to which the convergence rate of the plates is expressed in major thrust earthquakes also seems to decrease southwestward: in the Aleutian arc, probably all the plate convergence is accounted for by faulting associated with major earthquakes, whereas only about one fourth is accounted for at the southwestern end of the Kurile arc and almost none at the southern end of the northeast Honshu arc (Kanamori, 1976, 1978).

Decoupling between the converging plates seems required to permit subduction along the Northwest Honshu arc without the crustal strain that produces major earthquakes. This decoupling may be associated with the anomalously small accretionary wedge found at the trench off northeast Honshu by Von Huene, Nasu, and others (1978). They indicated that the volume of sediment brought to the trench atop subducting oceanic lithosphere in the late Cenozoic has far exceeded that now caught in the accretionary wedge. Most of it must have been subducted, therefore, either to cause, or more likely, to result from, decoupling between the plates. This lack of close coupling is attributed by Kanamori (1976) to active sinking of the subducting slab away from the Asian continent. By this argument, the subducting plate is not only plunging westward beneath Honshu and the Sea of Japan but is bodily sinking, so that the downward bend beneath the forearc terrane is migrating eastward.

The Miyagi-ken-oki earthquake occurred beneath the forearc terrane midway between the ends of the Northeast Honshu arc. Its setting is thus largely independent of the structural nodes at the junctions with adjoining arcs in the Tokyo-Fossa Magna region and south of Hokkaido. As shown in the schematic cross section representing structure across the center of the arc system (Figure 3.2), the subduction zone extends westward beneath the forearc terrane at an initial shallow angle of about $3\text{-}1/2^\circ$. Beneath the forearc basin, where the top of the subducting plate abuts the lower crust of northeast Honshu, the subduction zone gradually steepens until, free of the continental crust at about 30 km, it extends into the mantle at a dip of about 25° .

The full extent of the subduction zone is best shown by the three-dimensional pattern of earthquakes in the region (Figure 3.3). The earthquakes occur at greater and greater depth to the west, defining a Benioff zone that extends westward for more than 1,000 km beneath northeast Honshu and the Sea of Japan at an angle of about 25° , reaching depths greater than 500 km near the coast of Korea.

In greater detail (Figures 3.4 and envelope of seismicity in Figure 3.2), microearthquakes more precisely define the upper part of the subducting plate. The upper boundary of the subducting slab is clearly defined as dipping westward at about 25° beneath northeast Honshu, with a second westward-dipping zone of earthquakes within the slab about 40 km

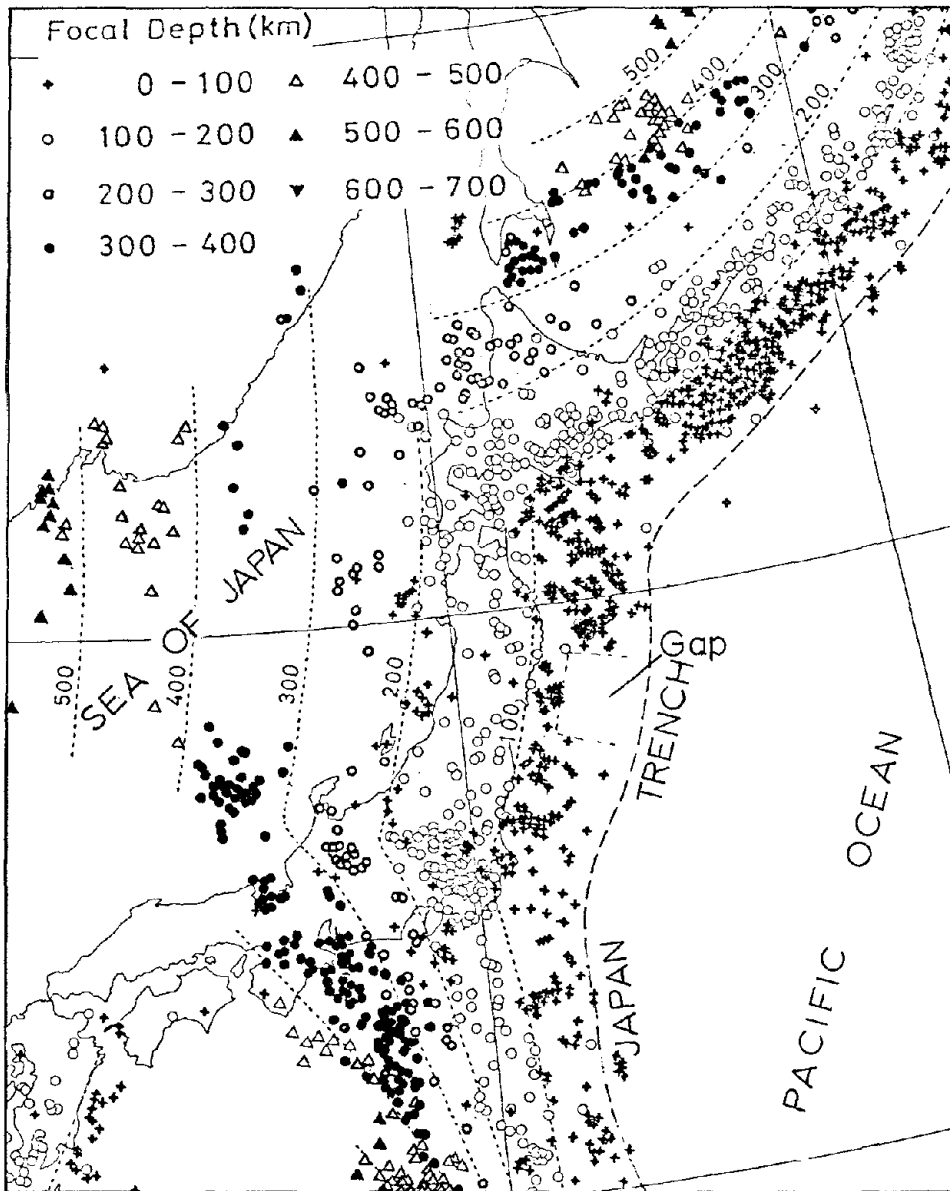

Figure 3.3 Earthquake hypocenters beneath Japan for the period 1964-1974. Epicenter symbols show depth of hypocenter, depth contours in kilometers. From Coordinating Committee on Earthquake Prediction (1978).

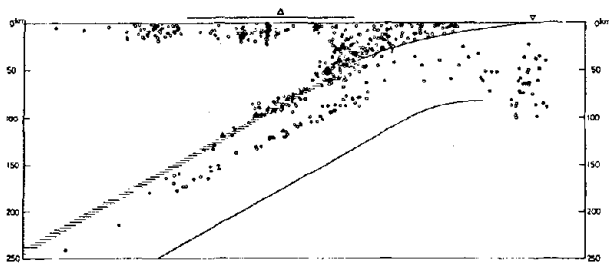

Figure 3.4 Distribution of micro-earthquakes (dots) beneath northeast Honshu in vertical, east-west section in the vicinity of 39-40 degrees north latitude, and subducting oceanic lithosphere. Horizontal line above section represents land, the upright triangle the volcanic front, and the overturned triangle the Japan Trench. From figure 6 of Takagi and others (1977).

beneath the first (Hasegawa and others, 1978; Takagi and others 1977). A zone of high activity is also shown above the subduction zone beneath the forearc terrane. The frontal arc is nearly aseismic, and a shallow zone of earthquakes extends westward from the edge of the frontal arc beneath the backarc geosyncline.

Analysis of the sense of first motions of microearthquakes recorded by the northeast Honshu seismographic network has been made by Hasegawa and others (1978) to determine the style of faulting associated with the earthquakes. These composite focal-mechanism solutions, although varied in detail, indicate that thrust faulting with compression nearly perpendicular to the trench is underway at and above the upper boundary of the subducting slab, as would be expected from the plate motions. In contrast, the band of seismicity within the slab involves extension along its dip direction.

Historic damaging earthquakes along the northeast Honshu arc form three groups evident in a compilation of damaging earthquakes that have occurred in and near Japan over the past one and a third millenia (Japan Meteorological Agency, no date; and Figure 3.5). A modest number of great earthquakes have occurred with epicenters near the trench, largely involving faulting along the gently dipping part of the subduction zone. Closer to shore, more numerous intermediate-size damaging earthquakes have occurred with epicenters in a band along the forearc basin trend. These earthquakes appear to involve faulting along the top of the steeper part of the subduction zone. A scattering of generally smaller damaging earthquakes has occurred with epicenters onshore, along and west of the Morioka-Shirakawa tectonic line. The frontal arc appears to be nearly free of damaging earthquakes, except in the gap between the Abukuma and Kitakami highlands near Sendai.

3.3 SEISMIC GAP AND PRECURSORS

The Miyagi-ken-oki earthquake of June 12 occurred adjacent to an area for which there was some evidence to suggest a forthcoming major earthquake. Gaps of uncertain significance existed in the pattern of both major and smaller earthquakes. The following summary is based on discussions held during the team visit in Japan and on Abe (1977), Coordinating Committee on Earthquake Prediction (1978), Mogi (1968), Kanamori (1976; 1978), and Shimazaki (1978).

The regularity with which great thrust earthquakes have occurred along subduction zones has led to the use of gaps in the pattern of fault rupture areas as a basis for identifying expectable earthquakes. The focal areas of the earthquakes tend to fill the length of the subduction zone with little or no overlap between adjacent events, and gaps in the pattern of the most recent earthquakes tend to be filled in. This regular pattern of repeated earthquakes extends around the northwest Pacific as far as the junction between the Kurile and Northeast Honshu arcs (Figure 3.6). At that junction, interpretation of tsunami data suggests that major thrust faulting and associated earthquakes occurred in 1677, 1763, 1856, and 1968, or about every hundred years.

The latest earthquake in that sequence, the Tokachi-oki earthquake of 1968 (Figures 3.5 and 3.6), is also the southwesternmost in the latest round of great earthquakes along the Kurile arc. East of the Kitakami block (or Sanriku region), the repeat history of major earthquakes seems less regular. And farther south, between latitude 36° and 38° N east of the Abukuma block, the 1938 Shioya-oki series of five large earthquakes (three thrust, two normal) seems to have been the only major earthquake event in at least the past 800 years. The transition along the Northeast Honshu arc from regular behavior of great thrust earthquakes at the north to almost no major earthquakes at the south complicates the application of seismic gap theory to the region east of Sendai. It is not clear whether or when the on-going subduction involves sufficient straining of the lithosphere to produce major earthquakes.

The last major subduction-zone faulting east of the Kitakami block between latitude 38° and 40°N occurred in 1896-1897, when the focal areas of the 1896 Sanriku and associated large earthquakes extended from within the focal area of the 1968 Tokachi-oki earthquake southward to about 38°. Only three earlier major earthquakes are known from the area--in 869, 1611, and 1677--although the historic record is incomplete. Thus the regular, hundred-year repetition of major earthquakes that characterizes the southwest Kurile arc does not persist south of about 40°. If strain has been accumulating since the Sanriku earthquakes of the

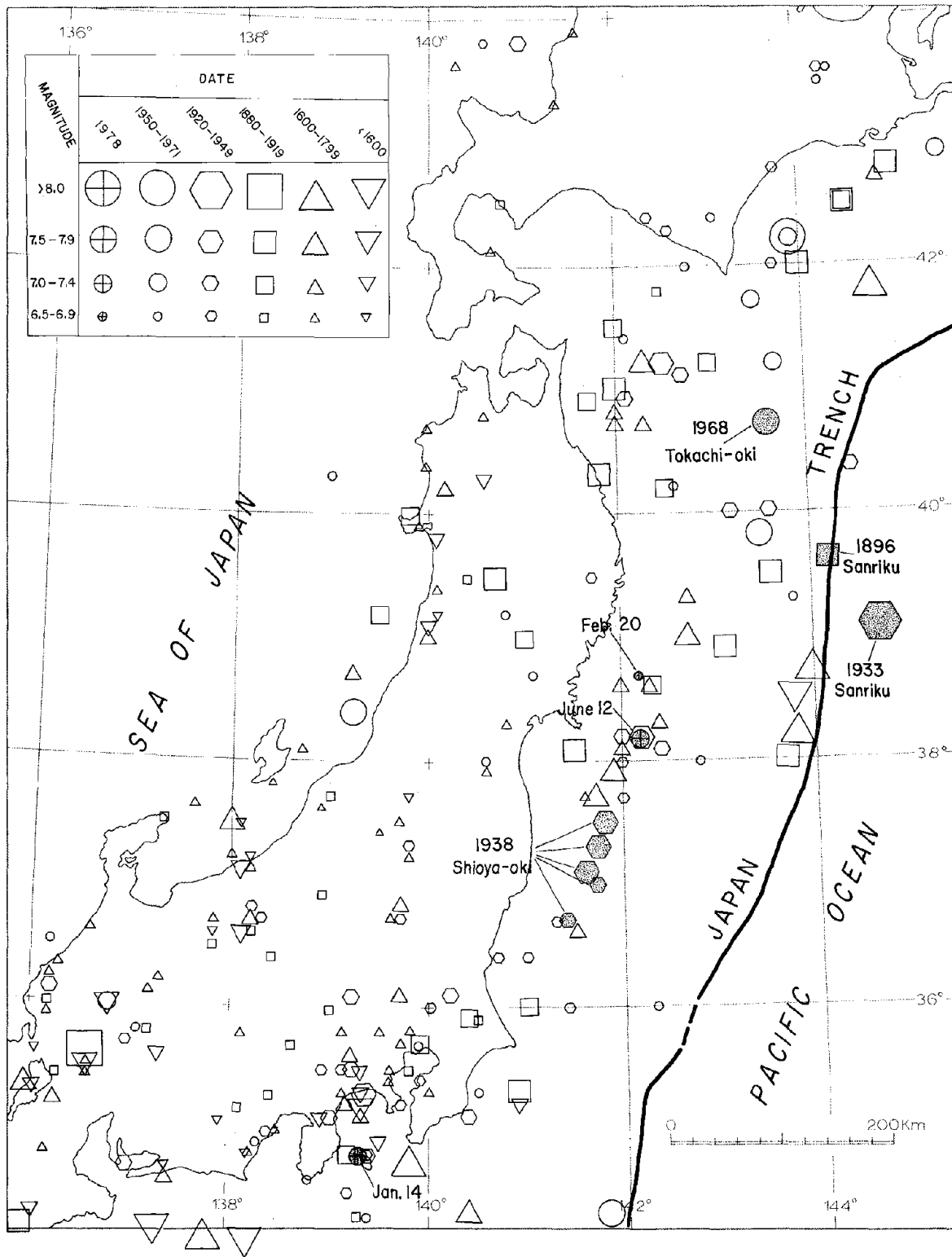

Figure 3.5 Historic damaging earthquakes in the northeast Honshu region. Compiled from 1:2,000,000 map. Disastrous Earthquakes in and near Japan, covering the period 599 to 1975. Older historic data are incomplete. Age classes are based on null points in temporal frequency of earthquakes throughout map area.

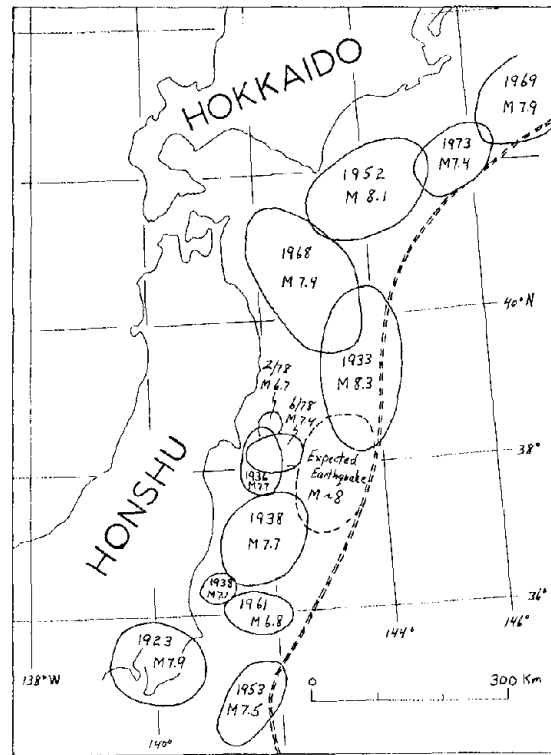

Figure 3.6 Source areas of recent major earthquakes along the subduction zone off Japan, with date and magnitude, and potential great earthquake at latitude 38. From Coordinating Committee on Earthquake Prediction (1978).

late 1890's, it has yet to be relieved by major thrust earthquakes. The role of the 1933 Sanriku earthquake is not clear. Apparently it was not a subduction-zone thrust event, but rather the product of normal faulting within the oceanic plate along a steeply west-dipping plane that extended through the oceanic crust.

Many large earthquakes seem to be preceded, for a period of years, by a lack of smaller earthquakes in the epicentral region. The absence of small earthquakes in the forearc terrane between about 37° and 39° (Figure 3.3) for a period of at least ten years amounts to such a gap in seismicity. This reinforces the uncertain suggestion from the pattern of major earthquakes that the region east of Miyagi may be about due for another major earthquake (Figure 3.6). Because the Miyagi-ken-oki earthquake of June 12 occurred adjacent to, but not within, this gap, a major earthquake may yet occur in the gap.

Particularly because of the seismic gap, other indications of the imminence of a large earthquake have been of interest. Spirit leveling had demonstrated an eastward tilt of the land opposite the gap, but no short-term precursors were recognized prior to the June 12 earthquake. Abundant data from the seismic network of Tohoku University showed no clear change in seismic velocities. Similarly, no indications of imminent earthquakes were evident from the extensometers and tiltmeters that are part of each station in that network.

Comparisons of measurements along two east-west level lines run by the Geographical Survey Institute that end at Sendai and Kamaisi show relative downward tilt to the east of 2 to 5 cm between the center of the island and the east coast in a 7-to-8-year period beginning in 1966. The tilt is greater at Sendai than farther north; an additional 3 cm of decline at Sendai may be related to withdrawal of ground water. Detailed tidal records in the area showed no evident changes with a resolution of a few centimeters within hours after the main shock of June 12, so that little or no coastal uplift accompanied that earthquake.

3.4 MIYAGI-KEN-OKI EARTHQUAKE OF JUNE 12

The magnitude 7.4 Miyagi-ken-oki earthquake occurred on June 12, 1978 at 5:14 PM local time, with its hypocenter at a depth of 30 km at latitude 38.2°N longitude 142.2°E (National Research Center for Disaster Prevention, 1978b). It followed by about 4 months a magnitude 6.7 earthquake that occurred 65 km to the north (latitude 38.7°N, longitude 142.2°E) at a depth of 60 km (National Research Center for Disaster Prevention, 1978a). The February 20 earthquake had a pattern of aftershocks distinct from that of the June 12 earthquake (Figure 3.7) and therefore was not simply a foreshock of the larger earthquake. The main June 12 shock was preceded by one foreshock a few minutes earlier, and was followed by many aftershocks, which were recorded by the seismographic network of Tohoku University (Figure 3.8). Figure 3.9 shows the hypocenter of the main shock and aftershocks through the first 7 hours (A) and aftershocks for the first 10 days following the main shock (B).

A focal-mechanism solution for the main shock, using worldwide data, indicates thrust movement along a preferred plane dipping to the west-northwest at 20° (Figure 3.10, Otsuka and others, 1978). Figure 3.2 shows this solution at the appropriate depth and position relative to the trench and volcanic front. Within the crude accuracy limits of the schematic cross section, the focal plane lies at the top of the subducting oceanic slab.

The aftershock pattern supports and extends this association. The two aftershock patterns of Figure 3.9 are nearly identical, indicating relative stability through time, and suggest mainshock rupture on a west-dipping plane that extends to a depth of about 50 km. The aftershock pattern of Figure 3.9B lies entirely within the equivalent pattern of Figure 3.4, at and above the top of the subducting slab.

The extent of the fault rupture zone can be estimated from the early aftershock pattern (Figure 3.9A). In the dip direction, it extends from at or somewhat above the mainshock hypocenter to a depth of about 50 km (Figure 3.2). This represents a fault width (or down-dip dimension of the focal area) of about 70 km, down which the rupture propagated from the up-dip hypocenter location. The lower end of the fault rupture is here estimated from the depth of the aftershocks, whereas the upper end is estimated from the relative positions of the mainshock epicenter and the eastern end of the aftershock pattern. The strike length of the aftershock pattern, although less well constrained than the east-west direction because of its position offshore of the seismic network, suggests a rupture-zone length of

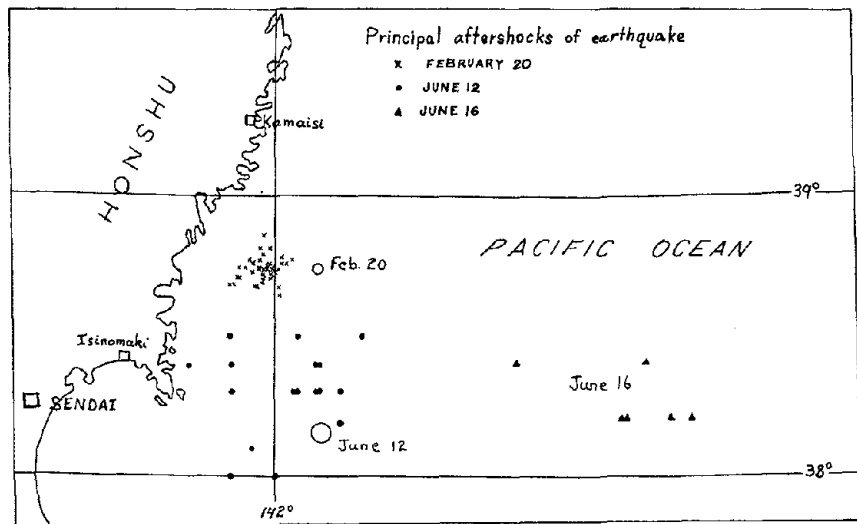
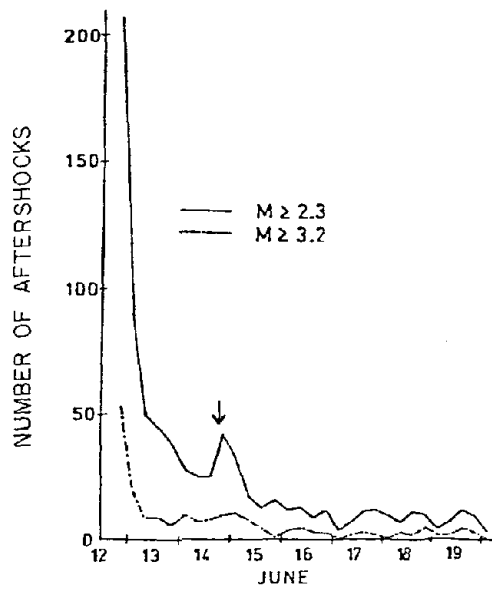

Figure 3.7 Epicenters of the earthquakes of February 20 and June 12, 1978 and principal aftershocks. From Coordinating Committee on Earthquake Prediction (1978).

Figure 3.8 Numbers of aftershocks of the June 12 earthquake through time. Arrow shows time of largest aftershock. From Coordinating Committee on Earthquake Prediction (1978).



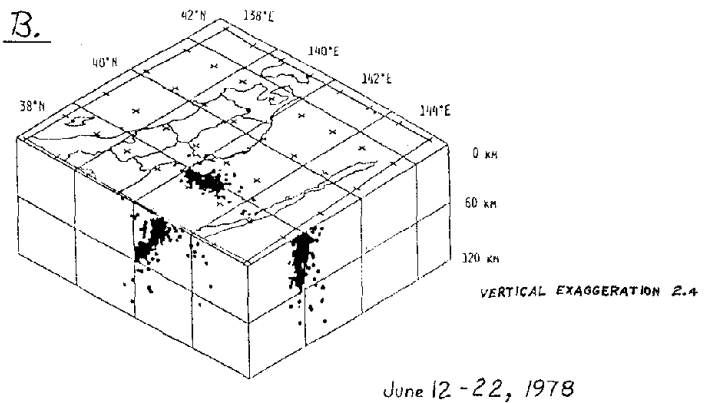
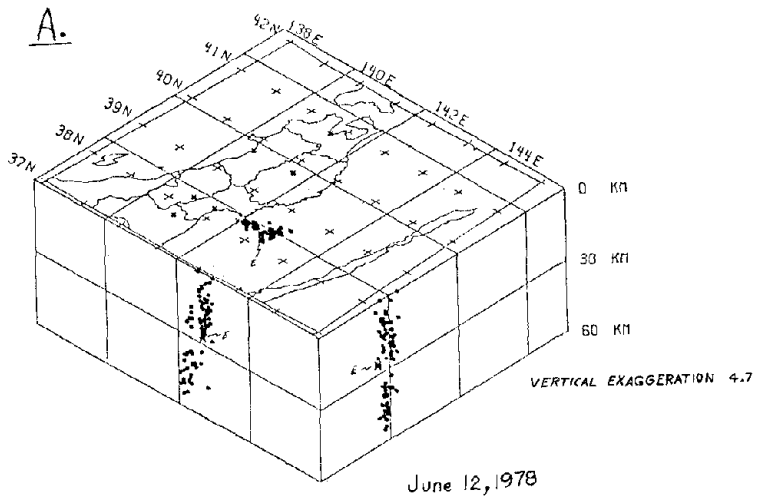

Figure 3.9 Hypocenters of June 12 mainshock and aftershocks through June 22. Block diagram shows projections of hypocenters in map view (epicenters), east-west vertical section, and north-south vertical section. A shows main shock at X (labelled E) and aftershocks through midnight of June 12 to 60 km depth. (From Coordinating Committee on Earthquake Prediction, 1978). E shows aftershocks through June 22 to 120 km depth (from figure provided by Observation Center for Earthquake Prediction, Tohoku University, June, 1978).

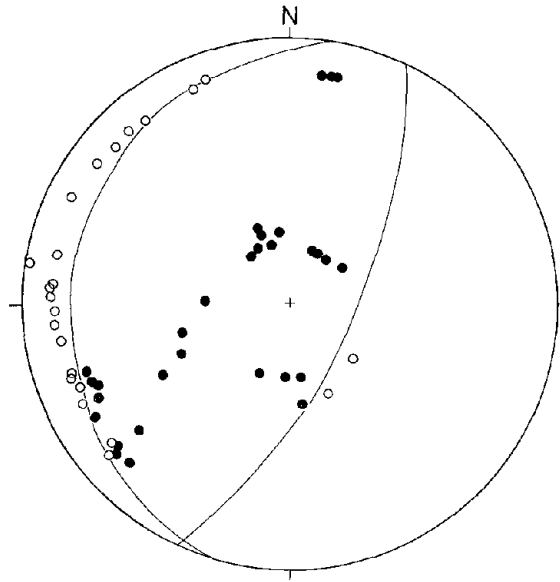

Figure 3.10 Focal mechanism

Figure 3.10 - Focal mechanism diagram for the June 12 main shock, using worldwide data. Filled circles represent compressions. From Otsuka and others (1978).

about 50 km. These dimensions are similar to the focal dimensions reported by Kobayashi and others (1978), a fault width of 80 km and a length of 30 km.

The June 12 earthquake thus occurred along the subduction boundary where it steepens before extending to depth in the mantle. Inasmuch as the focal area of the earthquake lies west of the seismic gap (Figure 3.6), the faulting did not encroach upon the area of unrelieved strain suggested by the gap. The locations of the June 12 earthquake and the earlier earthquake in February raised the possibility that they were precursors of a larger earthquake that would fill the gap. On June 16 several earthquakes as large as magnitude 5.9 did occur in the gap area (Figure 3.7). The aftershock train of the June 12 earthquake decayed rapidly, however, perturbed only by one aftershock somewhat larger than magnitude 6 and an associated increase in activity on June 14 (Figure 3.8).

3.5 LOCATION OF ENERGY SOURCE

The location of the source of seismic energy is an important parameter in studies of the attenuation of seismic shaking. The earthquake epicenter is commonly used as an approximation of this location, largely because epicentral locations are available for most modern earthquakes. Despite the convenience, however, measurement of attenuation distances from the epicenter of an earthquake can be highly misleading, as implied by Page and others (1972) in their discussion of peak acceleration and described by Youd and Perkins (1978) in their discussion of liquefaction.

Strike-slip rupture, for example, can pass close to a site of interest, even where the epicenter of the associated earthquake is far distant. This difference can be accommodated by using the shortest distance to the rupture trace rather than the longer epicentral distance. In the reverse faulting at San Fernando, California in 1971, the epicenter lay far north of the damage area in the San Fernando Valley. The inclined rupture surface extended to the ground surface within the damage area, however, so that distances to the nearby fault could be readily measured.

The fault rupture surface in the Miyagi-ken-oki earthquake of June 12 is less obvious, because the epicenter is offshore and the damage area on land lies in the down-dip direction of the inclined rupture surface. The epicenter of this earthquake is about 115 km east of the city of Sendai. The down-dip extent of the early aftershock pattern, however, lies 60 km west of the mainshock epicenter at a depth of about 50 km beneath the Osika Peninsula (Figure 3.9A). If these early aftershocks delineate the mainshock rupture surface, as is probable, then the faulting reached within about 75 km of Sendai in three dimensions and within 55 km in plan view.

3.6 GEOLOGY OF THE DAMAGE REGION

Most of the damage resulting from the June 12 earthquake occurred within the Miyagi region (shown in Figure 3.11), which consists of a broad central lowland bounded east and west by low mountains. To a considerable extent, the distribution and character of the damage were related to the geology of the region (see, for example, chapters 5 through 9 of this volume). The following discussion is compiled largely from the sources of Figures 3.11, 3.12, and 3.13 and Table 3.1, and discussions during the team visit in Japan, including information provided by H. Nakagawa (written communication, 1978).

The broad central lowland, in which much of the damage occurred, consists of low bedrock hills and extensive alluvial plains. It is bounded east and west by north-trending mountain ranges and on the southeast by Sendai Bay. Bedrock in the region consists of granitic and low-grade metamorphic basement, exposed almost exclusively in the southern Kitakami block and the northern tip of the Abukuma block, and a complex sequence of Miocene and Pliocene volcanic rocks and nonmarine to marine clastic rocks that overlie basement in the gap between the two highlands in the Sendai-Ishinomaki area. West of the Morioka-Shirakawa tectonic line, similar rocks are capped by Quaternary volcanoes. Uplift of the region during Quaternary time placed the Pliocene rocks well above sea level and raised the Abukuma and Kitakami blocks even further. Concurrent oscillation of sea level, as the world's glaciers waxed and waned, produced a sequence of coastal and river terraces that is well represented in the vicinity of Sendai. The alluvial plains of the central lowland represent the youngest deposits in the region, formed during recovery of sea level from the last glacial maximum 18,000 years ago.

Explanation for Figure 3.11

Qa	Quaternary alluvium
Qt	Quaternary terrace deposits
Qv	Quaternary volcanic rocks
Tp	Pliocene sedimentary and volcanic rocks
Tm	Miocene sedimentary and volcanic rocks
pN	pre-Neogene basement rocks: slate, sandstone, and schist
-----	Rifu-Nagamachi tectonic line; dotted where concealed
- -40 - -	Contour on late Pleistocene erosion surface beneath alluvium; contour interval 20 m, sea-level datum
---s---	Limit of bedrock information

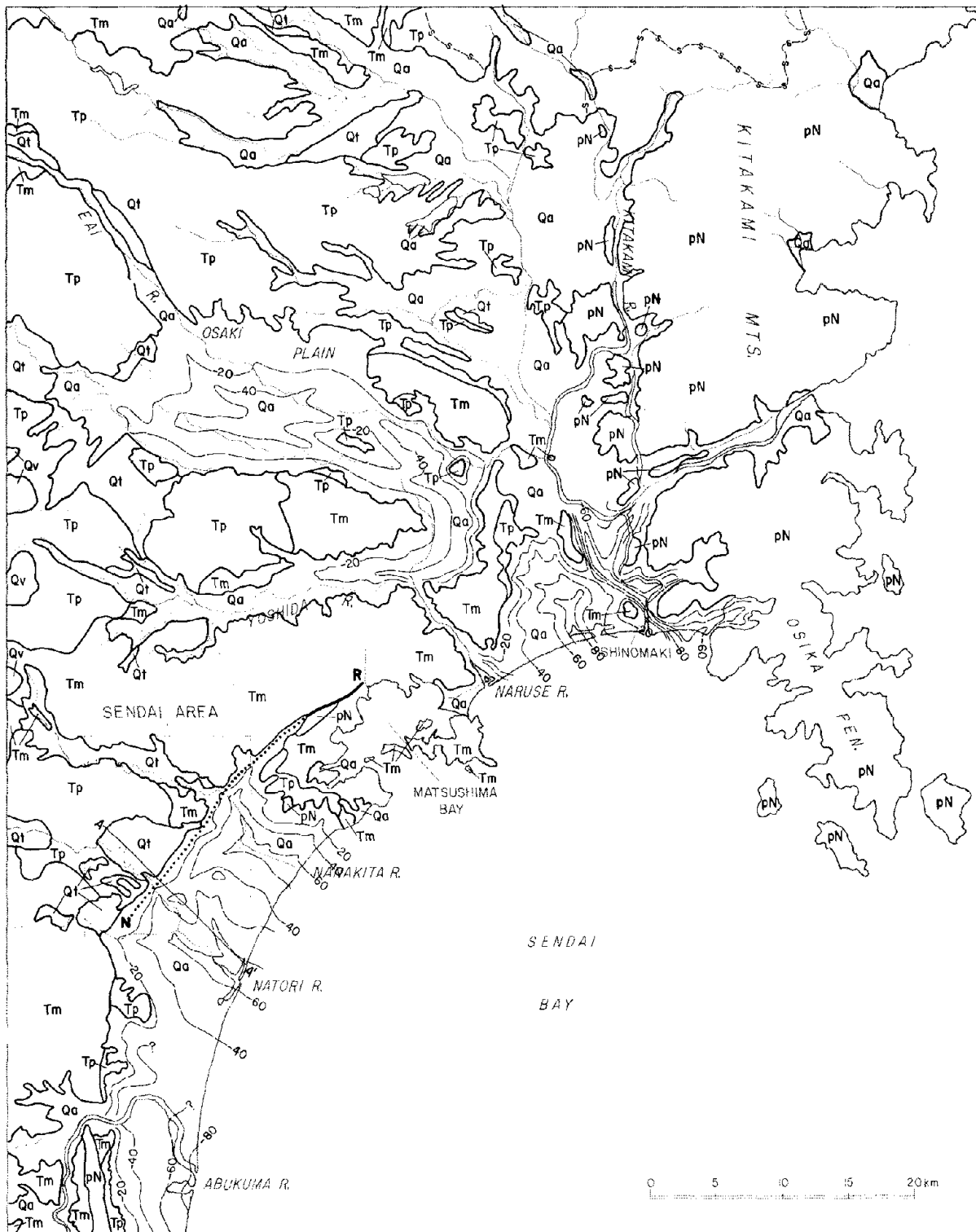

Figure 3.11 Geology of the Miyagi region. See Figure 1.1 for location. Compiled from 1:200,000-scale topographic maps published by the Geological Survey Institute of Japan, Geologic Map of Miyagi Prefecture at 1:200,000, Geological Survey of Japan (1968) and Hase (1967).

Explanation for Figure 3.12

Qp	Quaternary peat; in part overlaps alluvial fan deposits
Qa	Quaternary alluvium; much silt and clay, coarser along rivers
Qaf	Quaternary alluvial fan deposits; sand and gravel
Qt	Quaternary terrace deposits; sand and gravel; numbered 1 to 4 with increasing age
Tp	Pliocene sedimentary and volcanic rocks
Tm	Miocene sedimentary and volcanic rocks
---20---	Contour on late Pleistocene surface buried by Quaternary alluvium; contour interval 10 m, sea-level datum
·10—	Selected topographic contours, in meters
-----	Boundary of area of artificial cut and fill, superimposed on geology; hachures on inside

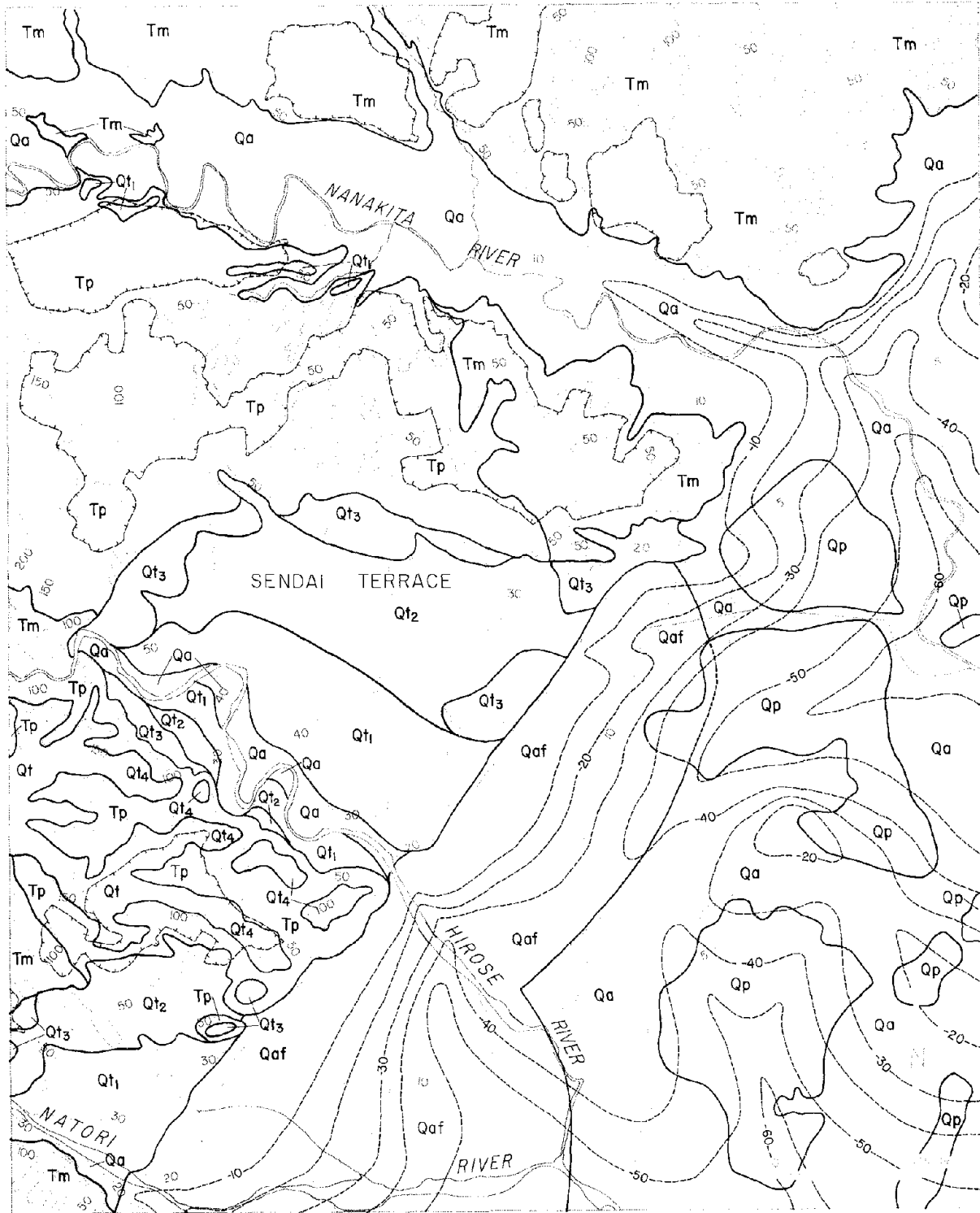

Figure 3.12 Geologic map of the Sendai area, Geology enlarged and generalized from discordant sources: Geologic Map of Miyagi Prefecture at 1:200,000, Geological Survey of Japan (1968), Hase (1967), and Shibata (1962). Base from 1:25,000-scale topographic map. See Figure 3.11 for location.

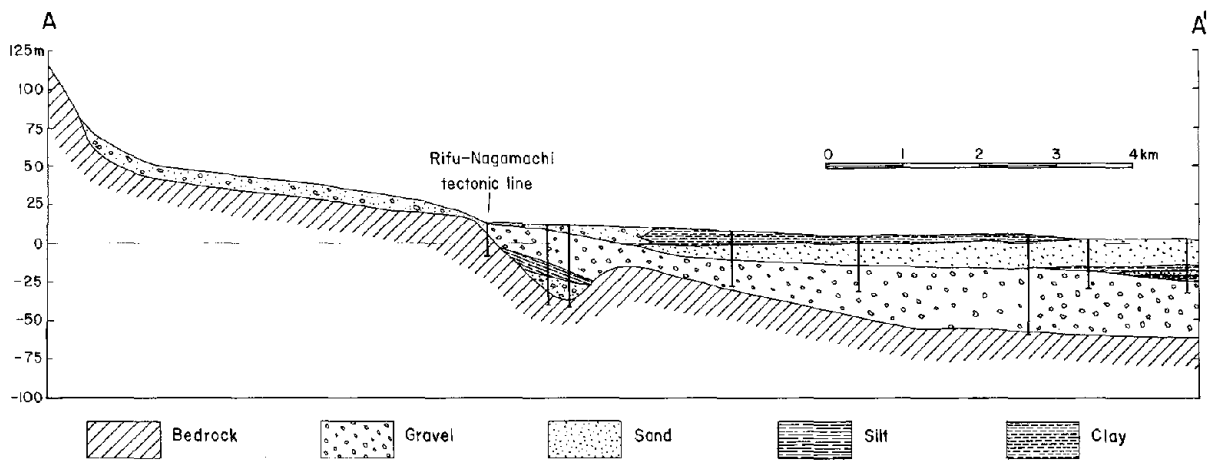

Figure 3.13 Cross section of surficial geology across Sendai terrace and coastal plain. Compiled from Hase (1967), Geological Survey of Japan (1968), and 1:50,000-scale topographic map. See Figure 3.11 for location.

Table 3.1

Stratigraphic Section in the Sendai Region
 An approximate, composite section compiled from H. Nakagawa
 (written communication, 1978) and Shibata (1962)

Quaternary alluvium: sand, gravel, and clay

--UNCONFORMITY--

Alluvial terrace deposits: sand and gravel

--UNCONFORMITY--

Pliocene Sendai Group

Dainenji Formation - 280 m, shallow marine: sandstone, with siltstone, tuff, and lignite

Mukaiyama Formation - 180 m, nonmarine sandstone, tuff and conglomerate with a 4- to 15-m tuff (Hirosegawa) near the base

--UNCONFORMITY--

Tatsunokuchi Formation - 300 m, marine: sandstone and conglomerate, siltstone, and tuff

Kameoka Formation - 100 m, nonmarine to brackish: sandstone and siltstone, conglomerate, tuff, and lignite

Mitaka Andesite - 200 m: lava and some agglomerate

--UNCONFORMITY--

Miocene Shirasawa Formation - 200 m, lacustrine: tuff, sandstone, siltstone, and conglomerate, with a 120-m tuff near the middle

--UNCONFORMITY--

Natori Group

Yumoto Tuff - 100 m: dacite tuff, pumice boulders

Hayama Tuff - 50 m: rhyolitic tuff

Tsunaki Formation - 475 m, marine: sandstone, tuff breccia, and siltstone and tuff

Hatate Formation - 200 m, marine: sandstone, siltstone, and tuff

Moniwa Formation - 75 m, marine: sandstone and conglomerate, calcareous

Takadate Formation (or Andesite) - 125 m: andesite, agglomerate, some rhyolite

Tsukinoki Formation - 15 m, nonmarine

--UNCONFORMITY--

Cretaceous and older Basement rocks of the Paleozoic Wariyami Formation (slate and schist), the Triassic Rifu Formation (slate and sandstone), and Cretaceous granitic rocks.

Uplands throughout the region are eroded into intricate, steep-sided ridges, but differences in altitude and relief and in the extent of alluviated lowland distinguish three north-trending topographic belts. (1) On the east, facing the sea, the southern end of the Kitakami block stands 200 to 500 m above sea level, with most slopes inclined between 30 and 50 percent. (2) West of this bulwark, across the south-flowing Kitakami River that marks its western edge, extend the alluvial plains and intervening areas of low, steep-sided hills that form the Kitakami lowland. The heads of the east-trending flood plains on the north-west and the inland edge of the coastal plain facing Sendai Bay on the southwest mark the western limit of this central belt. (3) The lowland is bounded on the west by hills that are nearly everywhere higher than 200 m. Southwest of Sendai, however, a wedge of lower, steep-sided hills extends northward off the end of the Abukuma block. At the northern end of this wedge, the hills bordering the Sendai terrace have valley walls commonly no steeper than 20 to 30 percent and a local relief generally less than 100 m.

The south end of the Kitakami block consists largely of hard, fractured slate and bedded sandstone of Triassic and Jurassic age that very locally contain Cretaceous granitic intrusions. Natural exposures seem nearly absent except along the coast, but the consistently steep slopes of this topographic belt bear only a very thin soil mantle over bedrock where observed in quarries and road cuts.

Most of the bedrock exposed in the region (Table 3.1) accumulated during Neogene time in a structural low in the Sendai region that crosses the frontal arc between the persistently emergent Abukuma and Kitakami blocks. The north-northwest trend of the boundaries of this gap suggests that it was controlled by pre-Mizuho basement structure. Andesitic to rhyolitic volcanism associated with the Mizuho orogeny extended through the Neogene, producing various flows, agglomerates, tuff breccias, and abundant tuffs. Superimposed on the sporadic eruption and erosion of these volcanic rocks was a sequence of three marine transgressions from the southeast and the accumulation of associated terrestrial to marine clastic sequences, separated by intervals of erosion. The limited areal distribution of individual volcanic units, erosion between times of accumulation, facies changes, and onlap relations of the transgressive sequences all combine to produce a complicated arrangement of geologic units.

The Quaternary deposits in the region, on which much of the earthquake damage occurred, consist of extensive young alluvial deposits in the lowlands and a sequence of late Pleistocene terrace deposits. The terrace deposits occur along the upper reaches of the east-flowing rivers near the margin of the western highland and in the Sendai area, where they underlie parts of the city.

The old part of Sendai City was built on the complex Sendai terrace, which consists largely of sand and gravel some 5 to 7 m thick overlying Neogene bedrock (Figure 3.12). These sediments are slightly consolidated, and yield N values of 20 to 60 (Kobayashi and others, 1978). Recent growth of the city led to expansion into the adjacent hills, where higher terrace deposits as well as Neogene bedrock were encountered, and eastward onto the Holocene coastal plain.

The alluvial sediments of the Sendai coastal plain and the other plains of the central lowland bury a late Pleistocene topography that consists of river valleys, flanking terraces, and divides (Figures 3.11 and 3.13). At the coastline, the bottoms of these valleys lie 60 to 90 m below sea level; they extend upstream approximately along the courses of the present surface drainage. From Ishinomaki, a deep, buried gorge extends northwestward for more than 10 km. North of Matsushima Bay, bedrock is 20 to 40 m deep along the Yoshida River for nearly 10 km above its junction with the Naruse River, and farther north, the paleo-Naruse valley beneath the center of the Osaki plain 30 km from the coast is still 40 m below sea level. In contrast, the valleys buried beneath the Sendai plain shallow rather abruptly from 50 to 60 m to less than 10 m below sea level within 6 to 8 km of the coast, near the Rifu-Nagamachi tectonic line.

The late Pleistocene topography was buried by alluvium in the past 18,000 years as the continental ice sheets of the last glaciation melted and sea level rose more than 100 m to its present position. The rise in sea level proceeded about an order of magnitude faster than the average rate of Quaternary uplift in the region, so that the rivers draining the uplands to the west and north found their progress gradually blocked by the rising sea. This caused

their sediment load to be deposited along their lower reaches, resulting in an effective drowning of the late Pleistocene topography that left upland islands and headlands flooded in a sea of alluvium. Along the outer side of the Kitakami block, the intricate drowned coastline misleadingly suggests major tectonic depression of the block.

As sea level rose, gravel and sand began to accumulate within the deep channels, and near the coast, ultimately filled them. Then, toward the middle of the Holocene, a central clay zone that ranges from 5 to 35 m thick was deposited across most of the alluvial terrane. Finally, a sand unit 10 to 20 m thick and an overlying sequence of clay and sand of similar thickness were deposited. This generalized alluvial section varies in detail from place to place in the central lowland. It closely represents the section beneath the Sendai plain, except that the central clay zone is limited to the shoreward part of the plain (Figure 3.13). The Osaki plain tends to lack the shallow sand unit, whereas in the Ishinomaki area the surface section is dominantly sand, giving way to thick clay sections in the eastern embayments.

The uppermost part of the alluvial section consists of an intricate assemblage of sediment types produced as the rivers migrated about on the aggrading plain. Under such circumstances, broad ribbons of channel sand and gravel are left as the rivers change their position from time to time, finer sand and silt are deposited in flanking natural levees in time of flood, and organic silt and clay accumulate in the intervening backmarsh areas. Low ridges of beach sand form along the shore. The sediment is soft and water-saturated, because it is young and the water table is very shallow.

The surface of the alluvial deposits is quite flat, and is still crossed by the several rivers responsible for depositing the sediment. Where not used for housing, much of the alluvial surface is covered with rice paddies. Surface geologic mapping distinguishes the four facies described: active and abandoned river channels, levees, intervening backmarsh peats and silts, and coastal beach sands (H. Nakagawa, oral communication, 1978). N values range from 1 to 10 in the Ishinomaki region, and to 20 on the Sendai plain. Frequent flooding of the rivers has led to the construction of many dikes, some of which were damaged in the June 12th earthquake.

3.7 REFERENCES

- 3.1 Abe, K., 1977, Tectonic implications of the large Shioya-oki earthquakes of 1938: *Tectonophysics*, v. 41, p. 269-289.
- 3.2 Coordinating Committee on Earthquake Prediction, 1978, Unpublished packet of information used by the Japan Coordinating Committee on Earthquake Prediction in its consideration on June 21, 1978 of the off-Miyagi earthquake of June 12, 1978, various pagings.
- 3.3 Dickinson, W. R., 1979, Plate tectonic evolution of north Pacific rim: *Journal of Physics of the Earth*, in press.
- 3.4 Geological Survey of Japan, 1964, Geological map of Japan: Geological Survey of Japan, scale 1:2,000,000.
- 3.5 Hase, K., 1957, Geology of the alluvial plains of Miyagi Prefecture: *Contributions from the Institute of Geology and Paleontology, Tohoku University*, no. 64, p. 1-45 (in Japanese, with abstract and figure captions in English).
- 3.6 Hasegawa, A., Umino, N., and Takagi, A., 1978, Double-planed structure of the deep seismic zone in the northeastern Japan arc: *Tectonophysics*, v. 47, p. 43-58.
- 3.7 Ishiwada, Y., and Ogawa, K., 1976, Petroleum geology of offshore areas around the Japanese islands: United Nations Economic and Social Commission for Asia and Pacific, Committee for Co-ordination of Joint Prospecting for Mineral Resources in Asian Off-shore Areas, Technical Bulletin v. 10, p. 23-34.
- 3.8 Isomi, H., 1968, Tectonic map of Japan, II, Geologic provinces: Geological Survey of Japan, 1:1,000,000 Map Series No. 12, sheet 2 of 2.

- 3.9. Japan Meteorological Agency, no date, Disastrous earthquakes in and near Japan: Japan Meteorological Agency scale 1:2,000,000 (publication recent but no date given).
- 3.10. Kanamori, H., 1976, Seismic and aseismic slip along subduction zones and their tectonic implications in Talwani, Manik, and Pitman, W. C. III (eds) Island arcs, deep sea trenches and back-arc basins: American Geophysical Union, Maurice Ewing Series 1, p. 168-174.
- 3.11. _____, 1978, Nature of seismic gaps and foreshocks, in Evernden, J. F., Isacks, B. L., and Plafker, George (convenor and coorganizers) Methodology for identifying seismic gaps and soon-to-break gaps: U.S. Geological Survey Open File Report 78-943, p. 319-334 and 904-906.
- 3.12. Kitamura, N., and Onuki, Y., 1973, Geological and crustal sections of the A-zone, northeast Japan in Japanese National Committee for Upper Mantle Project 1973, The crust and upper mantle of the Japanese area, part II, geology and geochemistry, Geological Survey of Japan, p. 38-60.
- 3.13. Kitamura, Shin, no date, Geologic map of Miyagi Prefecture: Tohoku University, scale 1:200,000. Publication recent but no date given.
- 3.14. Kobayashi, H., and others, 1978, A report on the Miyagi-ken-oki, Japan earthquake of June 12, 1978: National Science Foundation and others, Proceedings of the Second International Conference on Microzonation, v. 1, p. 587-614.
- 3.15. Matsuda, T., 1976, Empirical rules on sense and rate of recent crustal movements: Journal of the Geodetic Society of Japan, v. 22, no. 4., p. 252-263.
- 3.16. _____, 1977, Estimation of future destructive earthquakes from active faults on land in Japan: Journal of Physics of the Earth, v. 25, suppl. p. s251-s260.
- 3.17. Mogi, K., 1968, Some features of recent seismic activity in and near Japan (1): Earthquake Research Institute Bulletin, v. 46, p. 1225-1236.
- 3.18. National Research Center for Disaster Prevention, 1978a, February 20, 1978 Miyagi-ken-oki earthquake: National Research Center for Disaster Prevention, Science and Technology Agency Japan, Prompt Report on Strong-Motion Accelerograms No. 14.
- 3.19. National Research Center for Disaster Prevention, 1978b, June 12, 1978 Miyagi-ken-oki earthquake: National Research Center for Disaster Prevention, Science and Technology Agency [Japan], Prompt Report on Strong-Motion Accelerograms No. 15.
- 3.20. Okutsu, Haruo, 1968, Hydrogeological map of the coastal region of Bay of Sendai: Geological Survey of Japan, map scale 1:100,000.
- 3.21. Otsuka, Michio, Sudo, Ken, Seno, Tetsuo, and Eguchi, Takao, 1978, Study of focal mechanism of the earthquake on the east coast of Miyagi Prefecture, Japan: International Institute of Seismology and Earthquake Engineering, Building Research Institute, and Faculty of Science, Tokyo University, unpublished report, 3 pages, 5 figures.
- 3.22. Page, R. A., Boore, D. M., Joyner, W. B., and Coulter, H. W., 1972, Ground motion values for use in the seismic design of the Trans-Alaska pipeline system: U.S. Geological Survey Circular 672, 23 p.
- 3.23. Research Group for Quaternary Tectonic Map, 1969, Quaternary tectonic map of Japan: Japanese National Research Center for Disaster Prevention, Science and Technology Agency, scale 1:2,000,000, 6 sheets (1 - Vertical displacements estimated with geomorphological method, 2 - Vertical displacements estimated with geological method, 3 - Vertical displacements compiled from the maps Nos. 1 and 2, 4 - Distribution of faults, 5 - Distribution of folds, 6 - Gipfel-flur).

- 3.24. _____, 1973, Explanatory text of the Quaternary tectonics map of Japan: Japanese National Research Center for Disaster Prevention, Science and Technology Agency, 167 p.
- 3.25. Shaw, H. R., Jackson, E. D., and Bargar, 1979, Volcanic periodicity along the Hawaiian-Emperor Chain: American Journal of Science, Jackson volume, in press.
- 3.26. Shibata, 1962, Geology of the Sendai and Nanakita-Sambongi areas Miyagi Prefecture, Science Rep. Tohoku University, 2nd Series, v. 34, p. 239-301.
- 3.27. Shimazaki, K., 1978, Correlation between intraplate seismicity and interplate earthquakes in Tohoku, northeast Japan: Seismological Society of America, v. 68, no. 1, p. 181-192.
- 3.28. Takagi, Hasegawa, Akira, and Umino, Norihito, 1977, Seismic activity in the northeast Japan arc: Journal of the Physics of the Earth, v. 25, Supplement p. S95-S104.
- 3.29. Von Huene, R., Nasu, N., and others, 1978, Japan trench transected: Geotimes, April 1978, p. 16-21.
- 3.30. Yoshida, T. (ed.), 1975, An outline of the geology of Japan: Geological Survey of Japan, 61 p.
- 3.31. Youd, T. L., and Perkins, D. M., 1978, Mapping liquefaction-induced ground failure potential: Proceedings of the American Society of Civil Engineers, Journal of the Geotechnical Engineering Division, v. 104, no. GT4, p. 433-446.

4. STRONGMOTION RECORDS AND DATA*

4.1 INTRODUCTION

In Japan, several government agencies are responsible for independent networks of strong-motion instruments located throughout the country. Among the larger of these accelerograph networks are those operated by the following agencies:

Railway Technical Research Institute (RTRI), Japanese National Railways

Strong Earthquake Motion Observation Center, Earthquake Research Institute (ERI),
University of Tokyo

Port and Harbor Research Institute (PHRI), Ministry of Transport

International Institute of Seismology and Earthquake Engineering, Building Research
Institute (BRI), Ministry of Construction

Public Works Research Insititute (PWRI), Ministry of Construction

Other organizations with interest in strong-motion recording include:

National Research Institute of Agricultural Engineering, Ministry of Agriculture and
Forestry

Nippon Telegraph and Telephone Public Corporation

Japan Building Center Foundation (JBC)

The Strong-Motion Earthquake Observation Council was established in 1967 within the National Research Center for Disaster Prevention (NRCDP) of the Science and Technology Agency. Records recovered from particular earthquakes by the various government agencies are made available to the public in the council's "Prompt Report" publication, which describes the records, gives peak accelerations and epicentral distances, and contains copies of some of the more interesting records. These and other earthquake records are published in the council's annual report. The agencies responsible for the accelerograph networks also report on digitization and analysis of the records collected by them that they consider significant.

4.2 THE SMAC ACCELEROGRAPH

The SMAC strong-motion accelerograph in its various versions has been the main Japanese strong-motion recording instrument since its development between 1951 and 1953 by the Japanese Committee for the Standard Strong Motion Accelerograph. In its earliest form (the SMAC-A), it consisted of a set of three mechanical oscillators which, through a series of linkages, scribed analog traces on a waxed-paper record that was driven past the recording pens at 1cm/sec by a hand-wound spring motor. The natural period of the transducer was 0.1 sec (frequency, 10 cps), and critical damping was provided with an air piston mechanism. A sensitivity of 25 gal/mm (i.e., 25 cm/sec² per mm), corresponding to approximately 4cm/g, was arranged for in the mechanical linkage and allowed recording of accelerations of 1g amplitude without the pens moving off-scale. Some of the models developed after the SMAC-A are listed with their important characteristics in the following table.

* Prepared by A. Gerald Brady, U.S. Geological Survey, Menlo Park, California.

	Damping (fraction of critical)	Natural period (sec)	Sensitivity (cm/g)	Recording speed (cm/sec)	Approximate Number
SMAC-A	1.0	0.1	4.0	1.0	33
SMAC-B	1.0	0.1	4.0	1.0	90
SMAC-B2	1.0	0.14	8.0	1.0	240
SMAC-C	1.0	0.1	4.0	1.0	18
SMAC-D	1.0	0.05	1.0	0.5	21
SMAC-E2	0.60	0.05	1.0	0.25	45
SMAC-Q	0.60	0.05	0.5	0.5	11

The last column indicates the distribution of the various models in 1975 obtained from the response to a questionnaire from the author while at the International Seismological Centre in Edinburgh. An additional 400 strong motion instruments were not included in this response and the total in March of 1974 was actually about 850 (Kuribayashi and others, 1977). By March of 1978 the number of SMAC-type instruments installed throughout Japan in structures or at ground level had reached 1200 (Iwaskai and others, 1978). Additional instrumentation, for example electromagnetic recorders, and special downhole systems are not included.

It is important to note from this table that the majority of the instruments of the SMAC type that are operated in Japan at this time have frequency-response characteristics that are different from the most common modern United States instruments that record on 70-mm or 7-in. film. In particular, the SMAC response at frequencies higher than 7 cps (for the SMAC-B2) or 10 cps (for the SMAC-A, -B, and -C) has been designed to be much less than we are used to seeing with United States instruments such as the SMA-1 or RFT-250. A glance at recordings from these earlier SMAC instruments confirms this lack of high-frequency content.

Another feature of the records made by SMAC-type instruments is that the pens draw arc-shaped curves that have constant radius which are obvious in the higher-amplitude motions. Although peak accelerations can be scaled off without requiring significant correction, it is evident that after digitizing a record with high amplitudes correction procedures must be adopted to handle this instrumental behavior before arriving at true time histories.

Recent developments in Japanese instrumentation have included higher natural frequencies (in the SMAC-D, -E2, and -Q instruments), the use of moving-coil electromagnetic transducers (in the ERS accelerograph developed by the Earthquake Resistant Structures Laboratory, Port and Harbor Research Institute), and recording on analog magnetic tape (in the SMAC-M instrument). The two instruments in the Engineering Building at Tohoku University, which recorded 240 gal (240 cm/sec², or 0.24g) and 980 gal (1g) at ground level and at the 9th floor, respectively, are SMAC-M instruments operated by the Building Research Institute.

4.3 ACCELERATION RECORDS AT GROUND LEVEL

Figure 4.1 shows the northern part of Japan and the locations of the strong-motion accelerograph stations that provided ground level, basement, or free-field records of the June 12, 1978, earthquake. The codes for the stations are indicated (for example, THO20) and their pertinent characteristics have been obtained from National Research Center for Disaster Prevention (1976) and are reproduced in Table 4.1. In addition to the records shown on the map, there exist 61 additional records taken at basement, first-floor, or ground level, mostly in Tokyo or its vicinity. Of these 61 records, the highest peak acceleration is 0.045g at an epicentral distance of 305 km.

The epicenter was provided by the Japan Meteorological Agency (JMA) and published by the National Research Center for Disaster Prevention, (1978). We have chosen to use these epicenter coordinates, namely, 38°09'N, and 142°13'E, in the sections of this report that discuss the epicenter and epicentral distances.

Figure 4.1 also shows the peak accelerations recorded at ground level, or at the basement of first-floor level in structures. The cities of Sendai and Miyako each have more than one recording. Each set of the three numbers shown gives the peak acceleration recorded

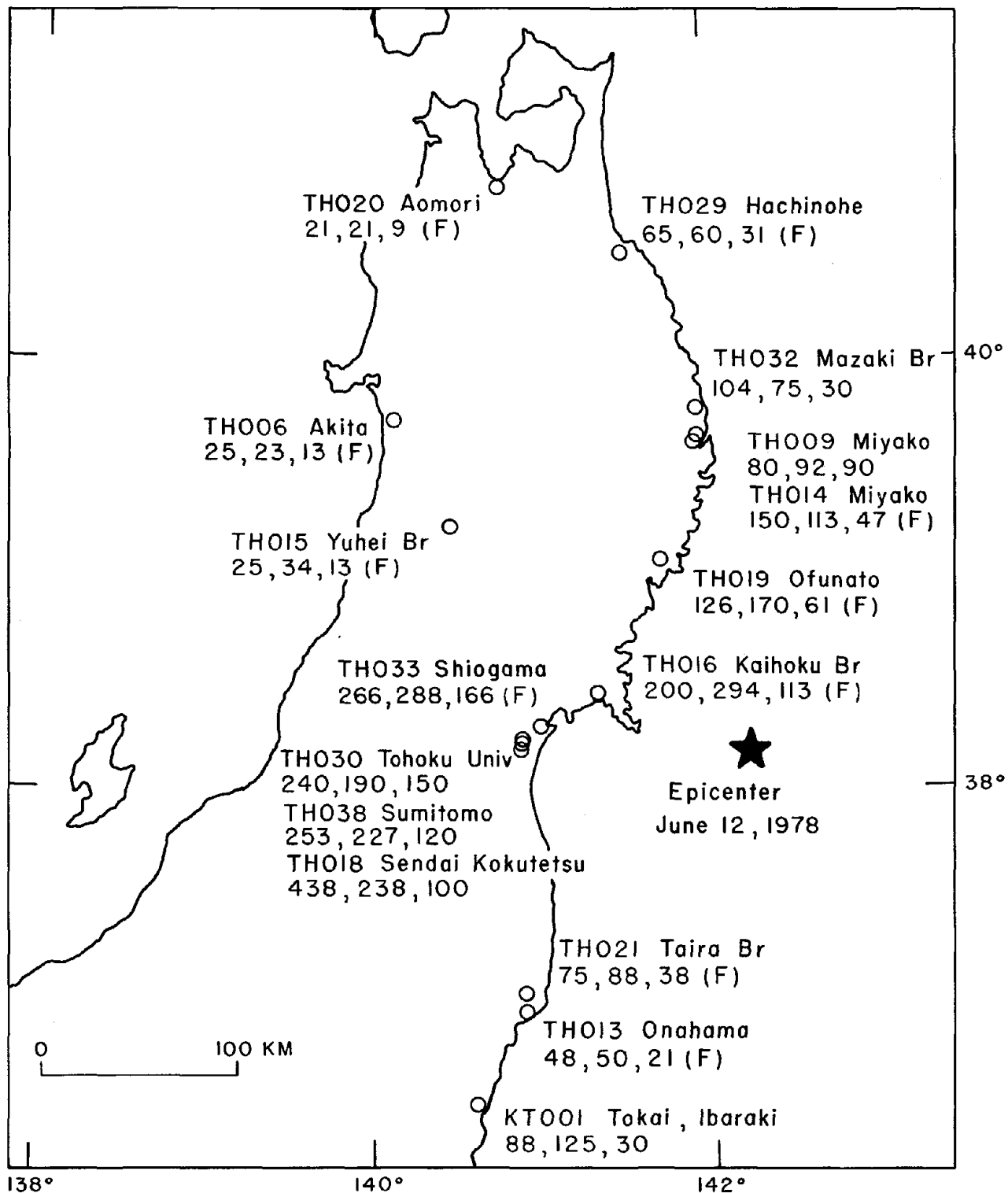

Figure 4.1 Locations of stations providing ground level, basement, or free-field records of the June 12, 1978 earthquake. Peak values in the two horizontal and the vertical directions are given in cm/sec/sec. An (F) following these values indicates an approximate free-field station.

Table 4.1 Ground Level Records

Site No.	Name	Address	Lat. & Long.	Location	Epicentral Distance (km)	Organization	Ground Level Peak Accns. Two horiz, one vert. (gals, cm/sec ²)
TH 006	On the Premises of Akita Harbour Works Office	Tsushizakiminato-Nishi 1-chome, Akita City	140°09'E 39°45'N	Ground	247	PHRI	25, 23, 13
TH 009	Schoolhouse of Atage Middle School, Miyako City	Nakasatodanchi, Miyako City	141°59' 39°38'	1F	150	BRI	80, 92, 90
TH 013	On the premises of 2nd Wharf, Omahama Harbour	Tatsumimachi, Iwaki City	140°54' 36°57'	Ground	190	PHRI	48, 50, 21
TH 014	On the Premises of Construction Section Miyako Harbour Works Office	Minatomachi, Miyako City	141°58' 39°38'	Ground	158	PHRI	105, 113, 47
TH 015	Yuhoi Bridge	Jumonji Town, Akita Prefecture	140°28' 39°12'	Crest of pier No. 8 ground	185	PHRI	25, 34, 13
TH 016	Kaiboku Bridge	Inai, Ishinomaki City	141°18' 38°26'	Crest of pier No. 2 ground	80	PHRI	200, 294, 113
TH 018	Sendai Kokuretsu Building	No. 28, Shimzukoji, Sendai City	140°55' 38°15'	B1F, 6F	110	RTRI	438, 238, 100
TH 019	Breakwater of Ofunato Harbour	Akasakicho, Ofunato City	141°44' 39°00'	On the Jetty, ground	100	PHRI	126, 170, 61
TH 020	On the premises of Aomori Harbour Works Office	Honcho 3-chome, Aomori City	140°49' 40°49'	Ground	305	PHRI	21, 21, 9
TH 021	Taira Bridge	Taira-Kamada, Iwaki City	140°54' 37°03'	Crest of Abut, ground	185	PHRI	75, 88, 38
TH 029	On the premises of Hachinohe Factory, Hachinohe Harbour Works Office	Kawaragi, Hachinohe City	413° 403°	Ground	268	PHRI	65, 60, 31
TH 030	Faculty of Engineering Tohoku University	Aramaki, Sendai City		1F	115	BRI	240, 190, 150
TH 032	Manaki Bridge	Taro Town, Iwato Prefecture	141°57'E 39°46'N	Crest of pier No. 1 ground	164	PHRI	104, 75, 30
TH 033	On the premises of Shioyama Harbour Office	Teizandori 1-chome, Shioyama City	141°03' 38°19'	Ground	160	PHRI	266, 288, 166
TH 038	Sumitomo Sendai Building	Chuodori, Sendai City		B2F, 9F, 18F	115	SUMITOMO	253, 227, 120
KT 001	Meteorological Laboratory, Japan Atomic Energy Research Institute	Tokai Village, Ibaraki Prefecture	140°37' 36°28'	1F	242		88, 125, 30

in two perpendicular horizontal directions and in the vertical direction. For most ground-level stations the two horizontal directions referred to are north-south and east-west, in that order, whereas the instruments at the lowest level of a structure are generally aligned in the longitudinal and transverse directions of the structure and acceleration values are reported in that order. The acceleration units used are cm/sec^2 , commonly called a gal. Conversion to g units is simply, if slightly inaccurately, accomplished by dividing by 1,000. An (F) following the acceleration levels indicates that the recording could be considered a free-field recording, although it must be realized that any instrumental housing disturbs the true free-field motion.

The section on seismicity indicates that, although the epicentral distance to Sendai is about 110 km to 115 km, it might be inferred from the aftershock pattern that the main shock rupture plane actually reached a point within about 75 km of Sendai, measured in three dimensions, or within a distance of 55 km, measured in plan. Such a conclusion would play a significant part in studies of the attenuation of peak accelerations for this earthquake, particularly for those stations within latitude 37.5° and 38.5° north that lie approximately due west of both the epicenter and the closest point on the rupture plane. Other stations on the east coast would not be affected because, for each of these, the epicentral distance is approximately equal to the distance to the closest point of the inferred rupture surface.

To illustrate this point in rather elementary fashion, Figure 4.2 shows the peak horizontal accelerations for three groups of ground-level records plotted against epicentral distance. A distinction is made between stations on the coast in a generally northern direction from the epicenter, those generally to the west, and those on the coast to the southwest. A curve labelled "Attenuation to the north" passes through the first group to the north and is a satisfactory approximation for the points of the third group, those to the southwest. Accelerations for the records lying to the west are higher than this curve would indicate, but on moving the points so that their plotted distance is the distance in plan, to the nearest point of the rupture, 60 km to the west of the indicated epicenter, a better fit is possible to an extrapolated attenuation curve. This curve only shows the trend of peak accelerations attenuating with distance - the scatter is evident and its explanation in individual cases will have to wait for detailed study.

4.4 INTENSITIES

Intensities for earthquakes in Japan are prepared by the JMA from information received at their headquarters from observational stations throughout the country. Like their Modified Mercalli equivalents used in the United States, JMA intensities are generally expressed in Roman numerals, but in the tables and figures of this report we have used Arabic numerals for clarity in their presentation.

A brief description of the JMA intensity levels is given in Table 4.2. A comparison of these descriptions with those of the Modified Mercalli Intensity Scale (Wood and Newman, 1931), the standard intensity scale in use in the United States, allows an approximate translation from JMA to MMI values. Considerable engineering judgment regarding the dynamic behavior of the various buildings and other structures in both cultures would be required for such a comparison to be accurate and useful. One possible comparison is shown in the following (Trifunac & Brady, 1975).

JMA	0	1	2	3	4	5	6	7				
MMI	1	2	3	4	5	6	7	8	9	10	11	12

Figure 4.3 is a highly idealized isoseismal map constructed from the plotted JMA intensities at specific locations. The indicated elongation of the isoseismals in the north-south direction is controlled by the locations of the lines as they pass over the land area, where observations are possible. Dashed lines across the Sea of Japan serve only to connect the two portions of the several isoseismals. No attempt is made to estimate the locations in the Pacific Ocean to the east.

The boundary between JMA 4 and 5 is reasonably well constrained to the north and west but less so to the south. The other isoseismals are more arbitrarily chosen. If a circular area were approximated to the JMA 5 region, its center would lie close, in plan, to the

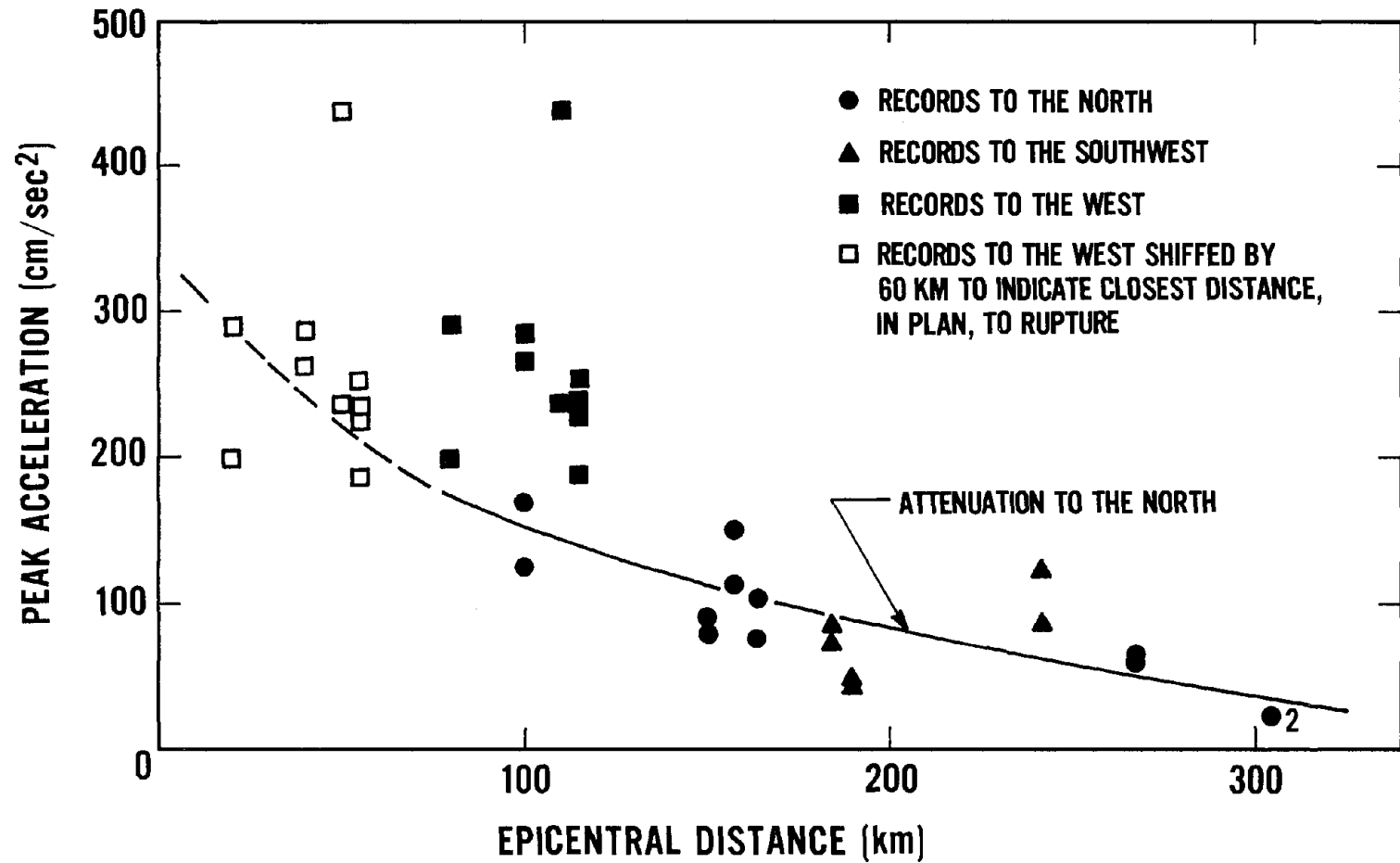

Figure 4.2 Attenuation of ground level peak accelerations with epicentral distance. The effect of shifting the points for records west of the epicenter to correspond to the distance to the closest rupture on the fault is shown.

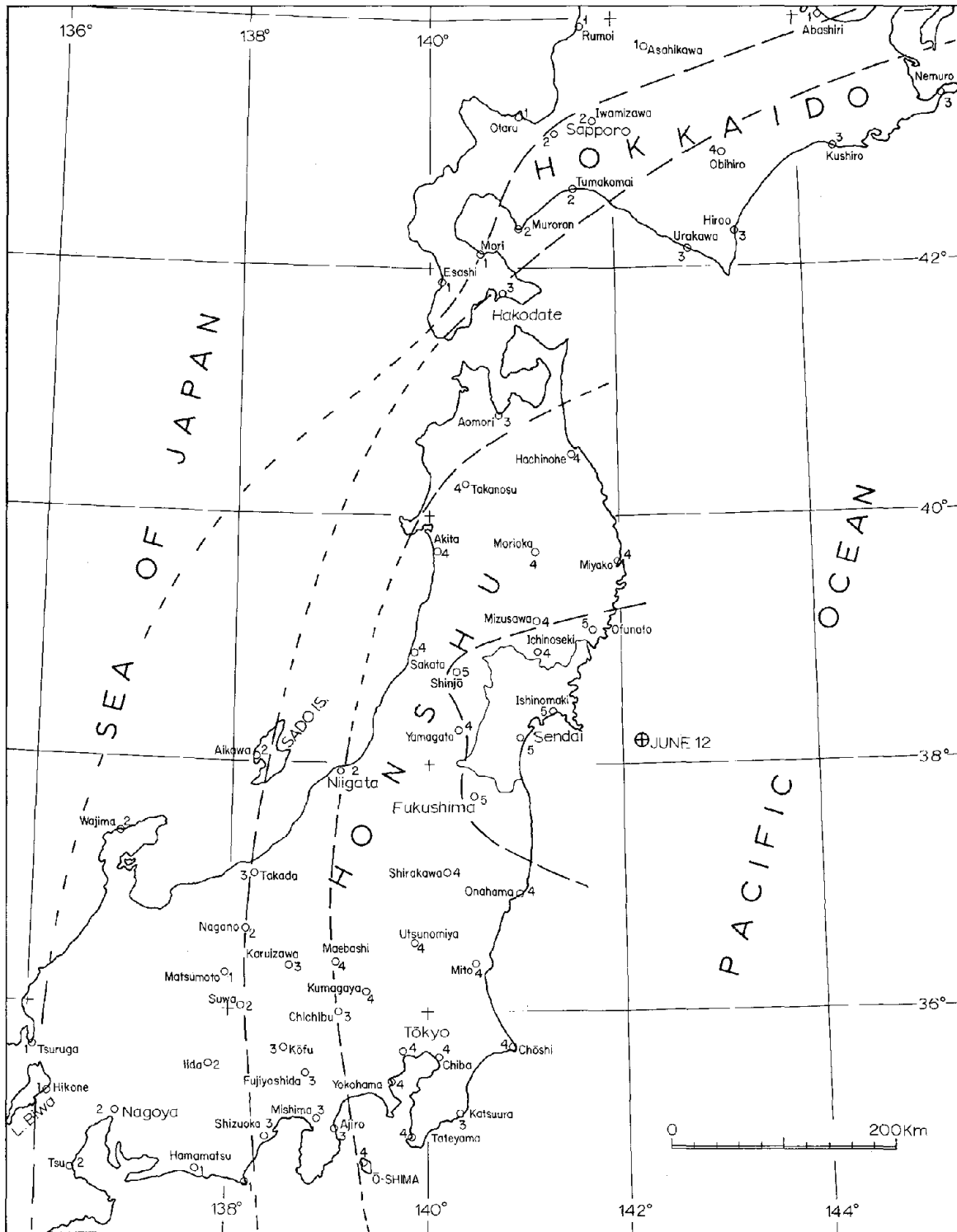

Figure 4.3 Isoseismal map for the June 12, 1978 earthquake.

Table 4.2 JMA Intensity Scale

- 0: Not felt. Shocks too weak to be felt by humans and registered only by seismographs.
- 1: Slight. Extremely feeble shocks felt only by persons at rest, or by those who are observant of earthquakes.
- 2: Weak. Shocks felt by most persons; slight shaking of doors and Japanese latticed sliding doors (shoji).
- 3: Rather strong. Slight shaking of houses and buildings, rattling of doors and shoji, swinging of hanging objects like electric lamps, and moving of liquids in vessels.
- 4: Strong. Strong shaking of houses and buildings, overturning of unstable objects, and spilling of liquids out of vessels.
- 5: Very strong. Cracks in sidewalks, overturning of gravestones and stone lanterns, etc.; damage to chimneys and mud and plaster warehouses.
- 6: Disastrous. Demolition of houses, but of less than 30% of the total, landslides, fissures in the ground.
- 7: Very disastrous. Demolition of more than 30% of the total number of houses, intense landslides, large fissures in the ground and faults.

westernmost down-dip end of the inferred rupture surface mentioned above. This lends credence to the conclusion that for this earthquake the distance from points on the ground surface to the nearest point of the rupture surface is the distance of importance in attenuation and related studies.

4.5 RECORDS FROM STRUCTURES

The Prompt Report (NRCDP, 1978) lists 191 strong motion records of the earthquake at epicentral distances ranging from 80 km (TH016 - Kaihoku Bridge) to almost 600 km, and includes records from 46 multi-instrumented structures such as buildings, bridges, and dams. About 100 of these records are from multi-instrumented buildings in the Tokyo area, at epicentral distances between 355 and 370 km. Although ground level accelerations here are low, some structural records have peaks of 10 percent g.

A selection of 22 instrumented structures are listed in Tables 4.3 to 4.6 with their instrument locations and peak accelerations at the various levels. Table 4.3 lists two low-rise buildings with less than six stories, Table 4.4 lists five medium height buildings between six and fifteen stories, Table 4.5 lists nine high-rise buildings with more than 15 stories, and Table 4.6 lists five bridges and a dam. All structures included in the tables have an associated ground level or basement record, and some of these have been included in Table 4.1 in the earlier section on ground level records.

The lists include the names, addresses and coordinates of the stations. Buildings are described by the number of stories above and below ground, while bridges, and the dam, have their length and width listed. The instrument locations in the buildings are indicated by story, including basement and penthouse or roof. For the bridges and dam the ground level recording station is usually off to one side of the structure on firm ground, while the structural recording station is usually on a pier cap, effectively at deck height. The peak accelerations at the listed instrument locations are given in cm/sec/sec (or gals) in groups of three - two horizontal and vertical component. Although the horizontal components are often listed as N-S and E-W in Japanese literature, these component names may actually be translated to mean the longitudinal and transverse axes of the recorder, and therefore also the longitudinal and transverse directions of the structure.

Table 4.3 Low-Rise Buildings (<6 Stories)

Site No.	Name	Address	Lat. & Long.	Number of Stories (above/below the G. L.)	Epicentral Distance (km)	Instrument Locations	Peak accelerations (cm/sec ²) 2 horiz. + 1 vert. at each level
KT 905	Bldg. E., Coll. of Ind. Tech., Nihon Univ., Tsudanuma	Izumicho, Marashino City	140°03' 35°42'	4/1	339	B1, 1, 4, RE.	21, 18, 9/15, 19, 10/56, 76, 14/64, 79, 14
TY 043	Takenaka Technical Institute	Minamisuna 2-chome, Koto Ward, Tokyo	139°49' 35°40'	4/0	363	1F, P1F(SF)	34, 26, 8/40, 53, 9

44

Table 4.4 Medium Buildings (6-15 Stories)

TH 030 TH 903	Faculty of Engineering Tohoku University	Aranaki, Sendai City		9/0	115*	1F, 9F(9F)	240, 190, 150/980, 480, 300
TK 013	Bokuto Hospital	Kotobashi, Sumida Ward, Tokyo	139°49' 35°42'	7/1	355	1F, P1F(8F)	28, 23, 5/40, 38, 10
TK 024	Earthquake Research Institute, University of Tokyo	Yayoi, Bunkyo Ward, Tokyo	139°45' 35°42'	6/1	355	B2F, 0L, 2F, P1F(7F)	18, 16, 8/24, 25, 10/38, 43, 13/75, 65, 10
TK 063	Mitsui Memorial Hospital	Kanda-Izumicho, Chiyoda Ward, Tokyo		14/1	360	B1F, 7F, P1F(14F)	7, 10, 4/16, 25, 4/47, 54, 7
TK 055	Fuji Television, Head Office	Ichigaya-Kawadacho, Shinjuku Ward, Tokyo		14/2	370	B2F, 14F	18, 13, 3/75, -, 5

*Reduce by 60 km for plan distance to nearest rupture.

Table 4.5 High-Rise Buildings (<15 Stories)

Site No.	Name	Address	Number of Stories		Epicentral Distance (km)	Instrument Locations	Peak accelerations
			Lat. & Long. (above/below the G. L.)				2 horiz. + 1 vert. at each level P
TH 038	Sumitoma Sendai Building	Chudori, Sendai City		18/2	115	B2F, 9, 18	253, 227, 120/393, 520, 207/487, 553, 227
TK 039	Head Office, Fuji Bank, Ltd.	Ohtemachi, Chiyoda Ward, Tokyo	139°46'E 35°41'N	16/4	360	B4F, 8, 16	15, 13, 8/63, 43, 13/108, 85, 11
TH 050	Kasumigaseki Building	Kasumigaseki 3-chome, Chiyoda Ward, Tokyo	139°45'	36/4	360	B3F, 3, 13, 23, RF	11, 11, 11/15, 15, 7/25, 23, 11/24, 21, 18/25, 24, 34
TK 074	Hotel Grand Palace	Iidabashi 1-chome, Chiyoda Ward, Tokyo	139°45' 35°41'	24/4	360	1F, P1F(25F)	19, 19, 13/44, 58, 20
TK 058	Fuji Photo Film Co.	Nishi-Azabu 2 chome, Minato Ward, Tokyo		18/3	370	B3F, 7, 18	6, 11, 3/25, 23, 6/39, 40, 5
TK 070	Hotel Pacific Tokyo	Takanawa 3-chome, Minato Ward, Tokyo	139°44' 35°37'	29/3	370	B3F, 5, 20, 30	19, 13, 13/44, 19, 6/---/94, 38, 38
TK 104	International Communication Center	Nishi-Shinjuku 2-chome, Shinjuku Ward, Tokyo	139°41' 35°41'	36/3	370	B3F, 7, 15, 24, 33	13, 12, 9/28, 25, 9/25, 32, 10/23, 16, 15/35, 42, 19
TK 105	Shinjuku Mitsui Building	Nishi-Shinjuku 2-chome, Shinjuku Ward, Tokyo	139°41' 35°41'	55/3	370	B3F, 13, 28, 42, P1F(RF)	11, 9, 7/30, 19, 12/32, 16, 20/20, 15, 26/36, 23, 28
KT 008	Hotel Empire	Matanocho, Totsuku Ward, Yokohama City	139°30' 35°23'	22/2	390	B2F, 9, 22	15, 14, 6/60, 33, 13/158, 128, 18

*Reduce by 60 km for plan distance to nearest rupture.

Table 4.6 Bridges and Dams

Site No.	Name	Address	Lat. & Long.	Length & Width	Epicentral Distance (km)	Instrument Locations	Peak accelerations 2 horiz. + 1 vert. at each level
TH 016	Kaihoku Bridge	Iuiai, Ishinomaki City	141°18' 38°26'	l=285m w=6m	8km*	GL, pier cap 2	200,294,113/>500,338,188
TH 032	Mazaki Bridge	Taro Town, Iwate Prefecture	141°57'E 39°46'N	l=150m w=8m	164	GL, pier cap 1	104,75,30/119,299,45
TH 015	Yuhei Bridge	Jumonji Town, Akita Prefecture	140°28' 39°12'	l=456m w=6m	185	GL, pier cap 8	25,34,13/35,50,16
TK 021	Taira Bridge	Taira-Kamada, Iwaki City	140°54' 37°03'	l=141.6m w=14m	185	GL, abutment crest	75,88,38/56,38,25
KT 021	Shin-Tonegawa Bridge	Kurihashi Town, Saitama Prefecture	139°42' 36°08'	l=654m w=7.25m	285	GL, pier cap 7	23,40,10/35,31,10
KT 030	Tonegawa Estuary Dam	Omigawa Town, Chiba Prefecture	140°40'E 35°50'N	l=834m w=16.5m	305	GL, gate 4	45,37,15/82,89,10

*Reduce by 60 km for plan distance to nearest rupture.

The investigating team inspected three of the structures on these lists: the Faculty of Engineering Building at Tohoku University, Aramaki, Sendai, described in a later section of this chapter; the Sumitomo Sendai Building, Chuodori, Sendai, described in the chapter on earthquake performance of buildings; and the Kaihoku Bridge, Inai, Ishinomaki, described in damage to transportation structures.

4.6 A Comparison with the Recorded Results of the San Fernando Earthquake, 1971.

An overall comparison, from an engineering viewpoint, of the recorded strong-motion data from the San Fernando, 1971, and Miyagi-ken-oki, 1978, earthquakes can be based on the following information.

1. The San Fernando magnitude was 6.4 with a focus at a depth of 13 km, the rupture propagating to the surface at the northern edge of the large metropolitan area of the city of Los Angeles and its surrounding cities and communities. The tall buildings of the city lie between 21 and 50 km from the epicenter.

The Miyagi-ken-oki magnitude was 7.4 with a focus at a depth of 30 km, the rupture probably travelling deeper but at a shallow angle towards the metropolitan area of Sendai. The aftershock pattern indicates that the rupture on the fault possibly approached as close as 75 km to Sendai. The high rise buildings of Tokyo are 350 km and more from the epicenter and from the nearest part of the fault rupture.

2. The closest recording to the San Fernando epicenter was at Pacoima Dam, at 8 km, or 4 km from the surface faulting, where the topography is extremely complicated.

The closest recording to the Miyagi-ken-oki epicenter was the ground level instrument at Kaihoku Bridge at 80 km. The closest distance to the rupture, at depth, however, is closer to 60 km and this distance in plan is 20 km. The peak acceleration recorded here was 0.29g.

3. At San Fernando, the next closest record was a 7-story building, the Holiday Inn at 8244 Orion, Los Angeles, with ground level accelerations of 0.27g.

At Miyagi-ken-oki the two buildings with complete instrumentation, that is at least two recorders including the lowest level of the structure, are at epicentral distances of 115 km, which reduce to 75 km to the nearest fault rupture, or 55 km in plan. Peak accelerations at ground level range up to 0.25g. None of these buildings, in either earthquake, suffered any severe structural damage; minor cracks in columns was the extent of the observed damage to structural members.

4. A total of 35 buildings higher than six stories produced complete sets of records from the San Fernando event at epicentral distances from 24 to 50 km, and ground accelerations ranging from 0.26g down to 0.04g. Minor cracking of structural members and extensive damage to nonstructural components were common.

The Miyagi-ken-oki event produced no further sets of records from tall buildings until the Tokyo area was reached, at epicentral distances of 340 to 370 km where acceleration amplitudes were .03g and less.

5. Recordings sufficient to give a useful engineering indication of ground accelerations and associated structural performance exist for San Fernando at epicentral distances from 20 km out to 75 km.

The same type of information for Miyagi-ken-oki ranges in distance from 80 km (reduced to 60 km, see above) out to about 200 km. Structures involved here are bridges, with ground level and pier cap accelerations, and various harbor installations.

6. The San Fernando records have been the basis for a large number of engineering and seismological studies, particularly, of course, the digitized versions of the records. Even now, there are still complete sets of building records that could be analyzed to study particular building behavior.

4.7 Tohoku University, Engineering Building

Tohoku University is situated in the northwest part of Sendai, in the district of Aramaki, an area of hills and steep terrain. The Engineering Building is a reinforced concrete framed structure and is built on a reasonably flat area, but a steep cliff falls off close to the rear of the building. Figure 4.4 is a photograph of the central 9-story tower and also shows the two lower levels which cover a larger plan area. A floor plan and two elevations are shown in Figure 4.5. Two SMAC-M instruments are installed in the building, at ground level (there is no basement), and at the 9th floor level. They are on the same vertical line, against an exterior wall of the central tower, as shown in Figure 4.5. These instruments record on FM analog tape, and functioned correctly during the earthquake.

The analog tape recordings were recovered and analyzed by the Building Research Institute, which was responsible for the instruments. After analog-to-digital conversion, a computer analysis was possible, and was completed within seven days (Watabe, 1978). The following figures are reproduced from the preliminary work.

Figure 4.6 shows a 25-sec portion of the record from the ground level instrument, after A/D conversion. The peak horizontal accelerations are 240 and 190 cm/sec/sec, and the peak vertical acceleration is 150 cm/sec/sec, as indicated in Table 4.1. Figure 4.7 shows a similar plot of the 9th floor record peak values of 980, 480, and 300 cm/sec/sec (Table 4.4). A preliminary analysis of the high-amplitude oscillations in the horizontal directions at this level indicate that the corresponding displacements are approximately 10 in (25.4 cm). This is consistent with the damage in the interior of the building, (discussed in Chapter 5), and indicates the building was approaching the structural damage state.

Figures 4.8, 4.9 and 4.10 show the correction procedures applied to the three ground level components. Acceleration velocity and displacement are plotted. Figures 4.11, 4.12, and 4.13 show spectral analyses performed on these records. The analyses include absolute acceleration response, relative velocity response, relative displacement response, and pseudo velocity response, the last being plotted in the tripartite 3-way response spectrum style.

4.8 Tracings of Records

Tracings of sections of the records from some of the closer stations are included. Figure 4.14 is the ground level record on the premises of Shiogama Harbor Office, site No. TH033, with peak values scaling off at 266, 288 and 166 cm/sec/sec. The arc-shaped curves drawn by the hinged arms are clearly evident on the high-amplitude excursions. Figure 4.15 shows the ground level record for site No. TH019, the breakwater of Ofunato Harbor, with peak values of 126, 170 and 61 cm/sec/sec. The amplitudes here are sufficiently high in a few instances to show their arc-shaped character. Figure 4.16 shows the first basement record at the JNR building at Sendai. The peak NS reading of 438 cm/sec/sec is the highest ground level amplitude in the city. The building has six stories, but no record was recovered from the station at the sixth floor. Consequently it is difficult to analyze this basement record and to ascertain the extent of the interaction between building and ground.

4.9 References

- 4.1. National Research Center for Disaster Prevention; Science and Technology Agency (Japan), March 1976, Strong-motion earthquake records in Japan, 1974, vol. 19.
- 4.2. National Research Center for Disaster Prevention, July 1978, June 12, 1978, Miyagi-ken-oki Earthquake: National Research Center for Disaster Prevention; Science and Technology Agency (Japan), Prompt Report on Strong-Motion Accelerograms No. 15.
- 4.3. Wood, H. O., and Newman, F. (1931). Modified Mercalli Intensity Scale of 1931, Bull. Seism. Soc. Am., 21, 277-283.
- 4.4. Trifunac, M. D., and Brady, A.C. (1975). On the correlation of seismic intensity scales with the peaks of recorded strong ground motion, Bull. Seism. Soc. Am., 65, 1, 139-162.



Figure 4.4

Engineering Building,
Tohoku University,
Aramaki, Sendai.

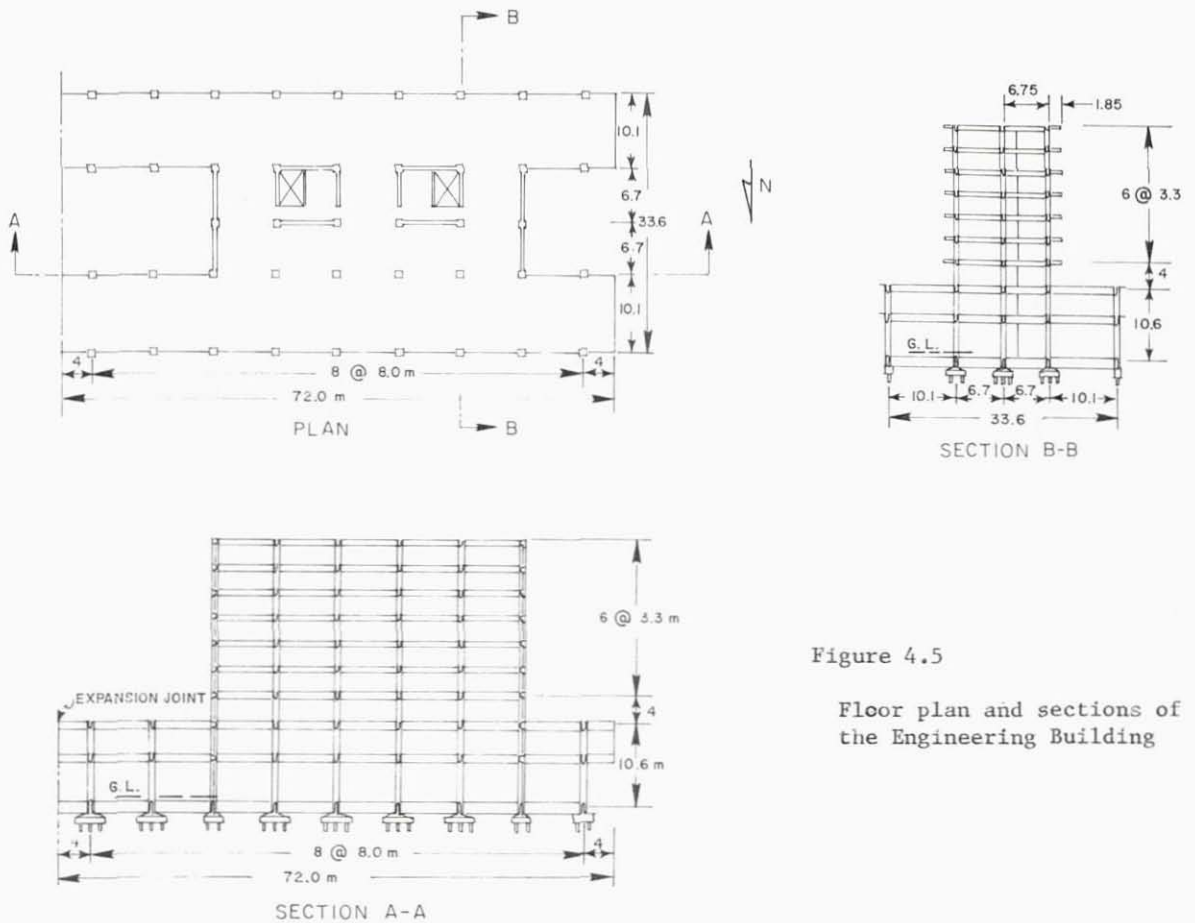

Figure 4.5

Floor plan and sections of
the Engineering Building

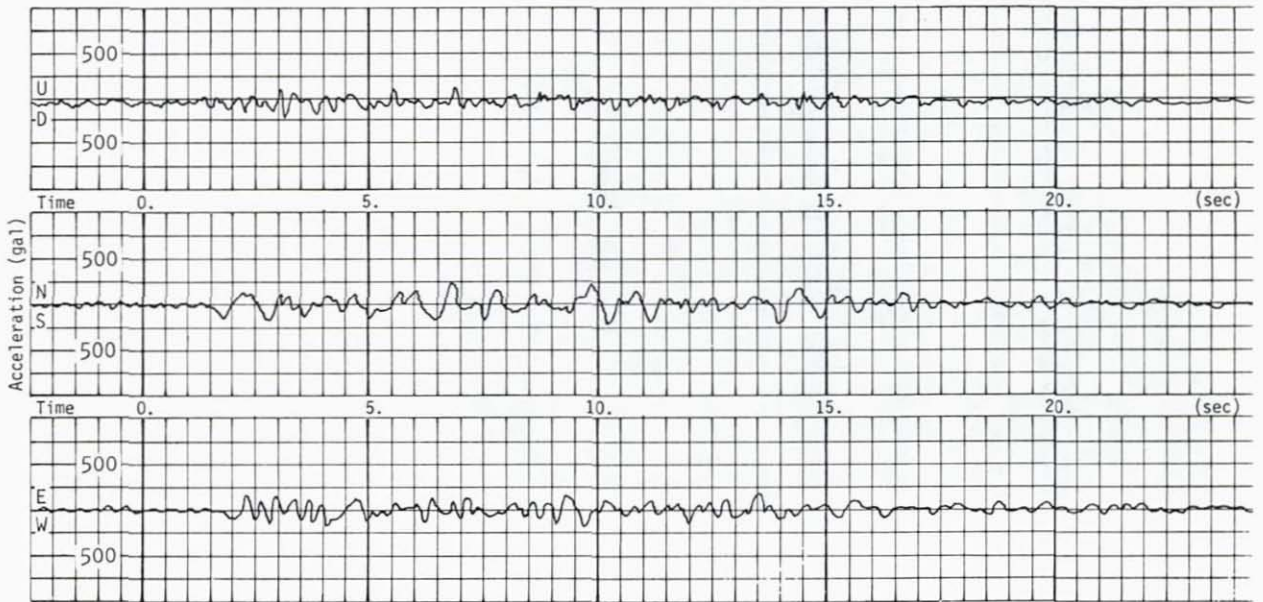

Figure 4.6 Three components, after analog-to-digital conversion, at 1st floor level, Engineering Building.

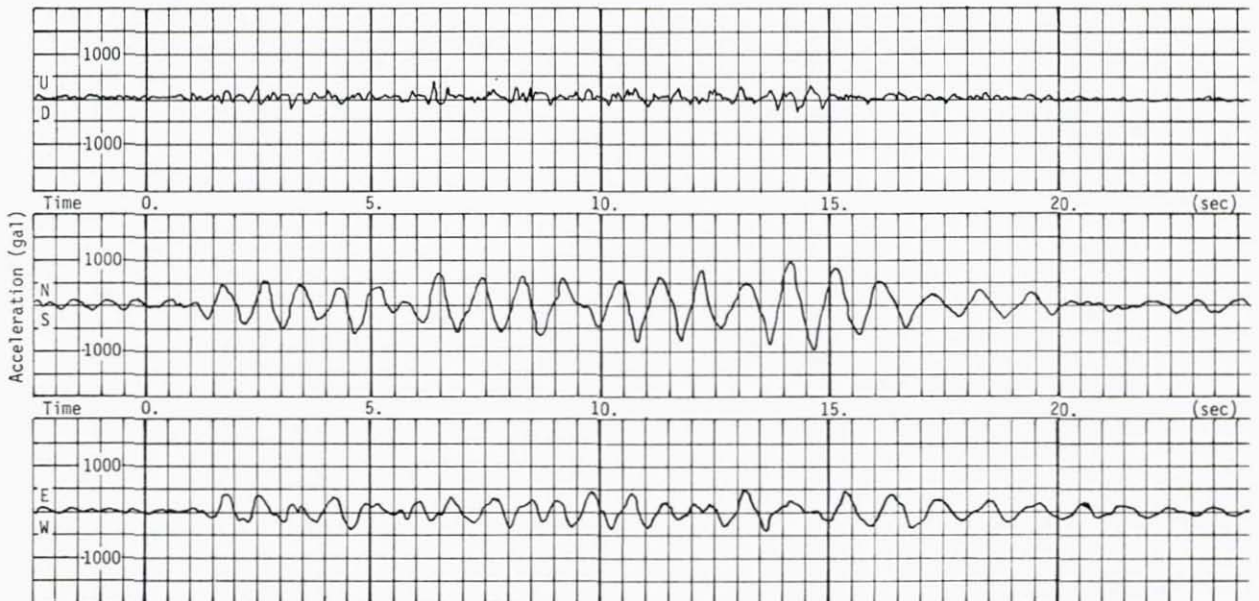
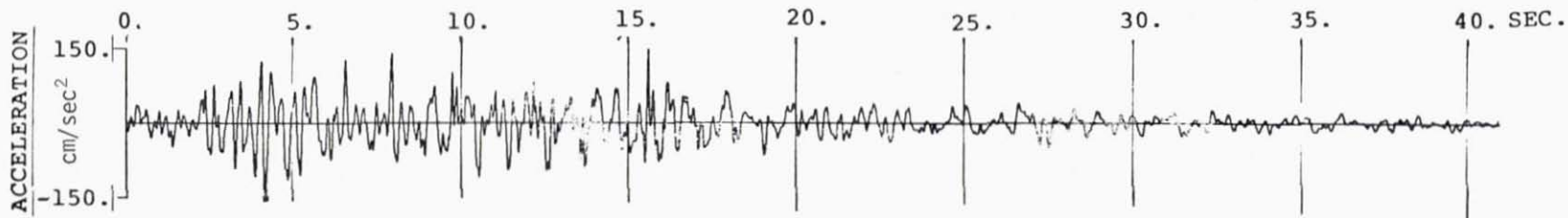

Figure 4.7 Three components at 9th floor level, Engineering Building.



MAX. VALUE= 152.9888 AT 4.1800 SEC.



MAX. VALUE= 12.2492 AT 9.7000 SEC.



MAX. VALUE= 6.1533 AT 3.8800 SEC.

Figure 4.8 Corrected acceleration, velocity, displacement for 1st floor, up-down component, Engineering Building.

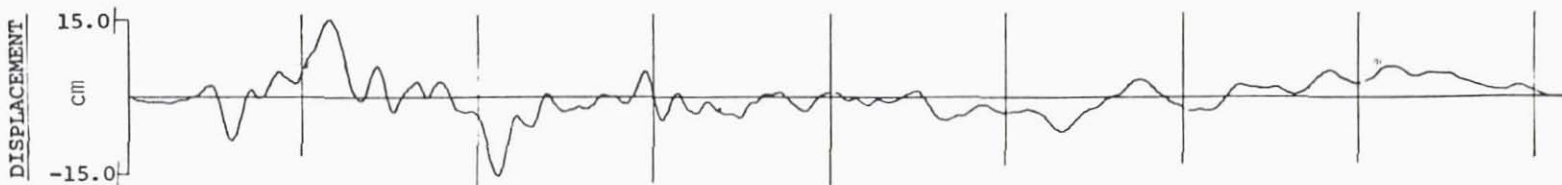
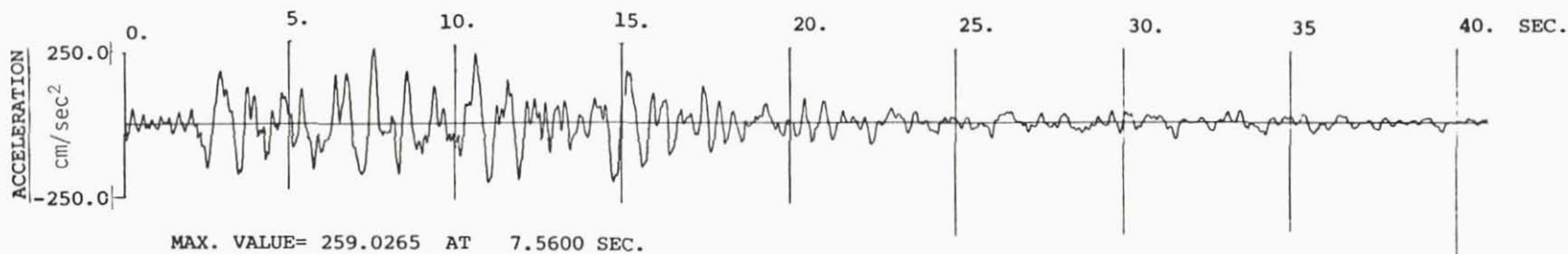
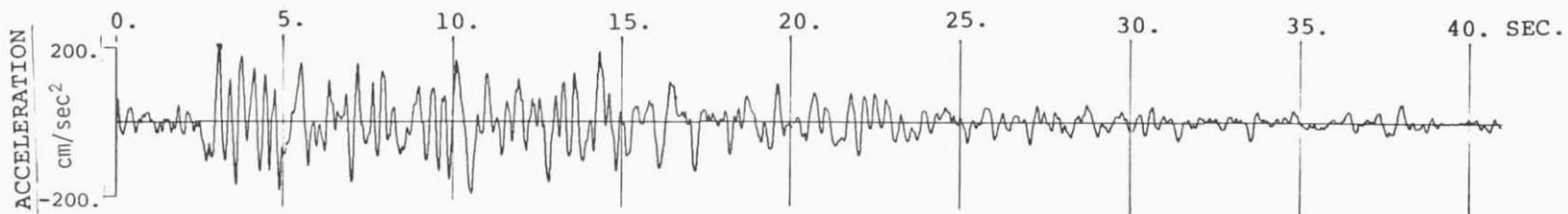

Figure 4.9 Corrected acceleration, velocity, displacement for 1st floor, north-south component, Engineering Building.



MAX. VALUE= 202.6549 AT 3.1000 SEC.



MAX. VALUE= 26.5594 AT 2.9600 SEC.

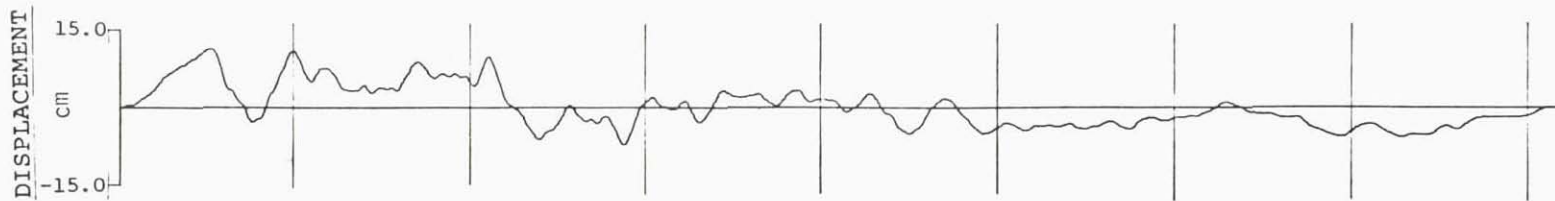

MAX. VALUE= 11.4080 AT 2.6200 SEC.

Figure 4.10 Corrected acceleration, velocity, displacement for 1st floor, east-west component, Engineering Building.

DAMPING : 0, 2, 5, 10, 20% CRITICAL

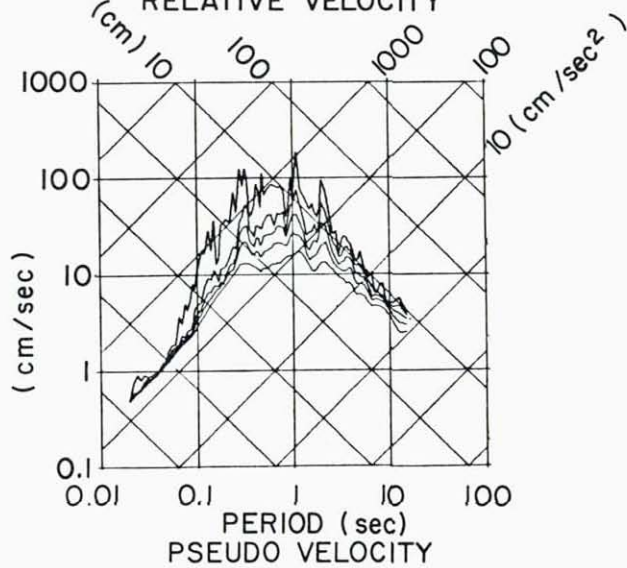
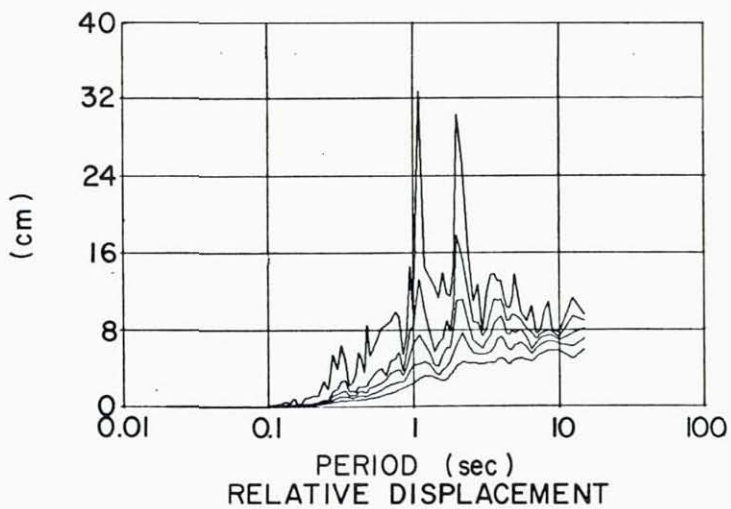
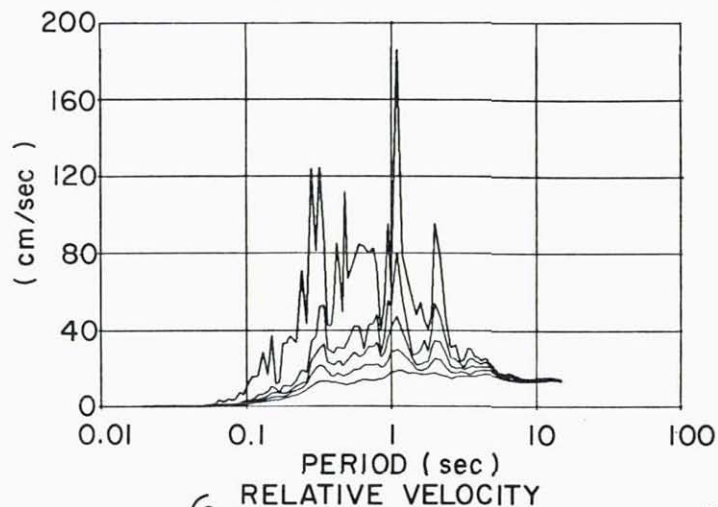
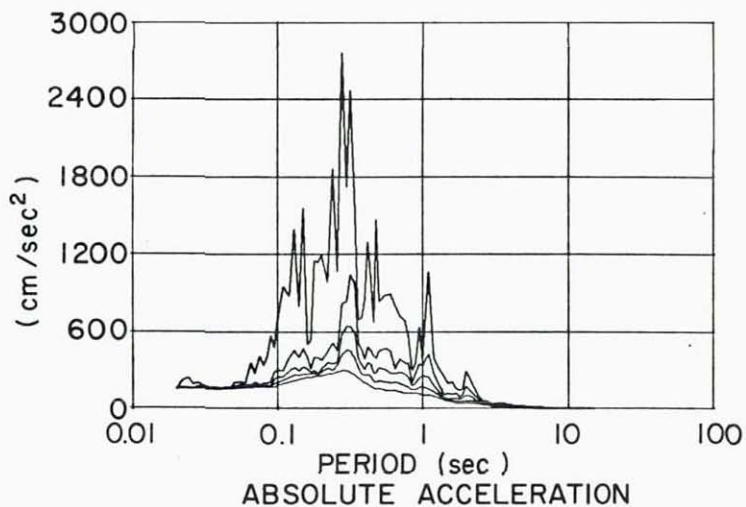

Figure 4.11 Spectra, 1st floor up-down component

DAMPING : 0, 2, 5, 10, 20 % CRITICAL

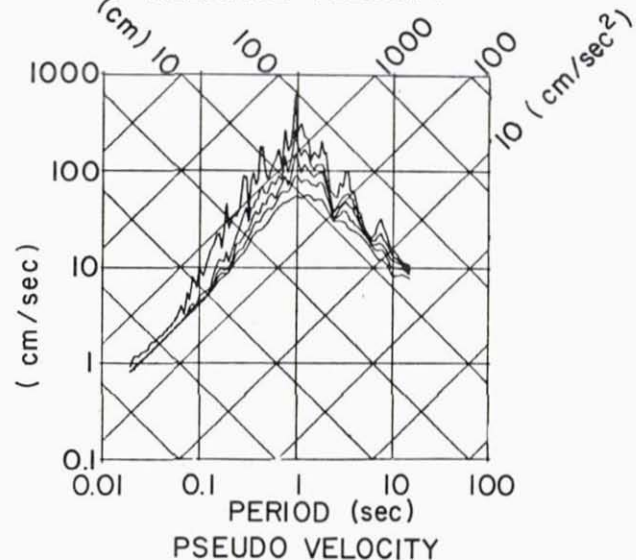
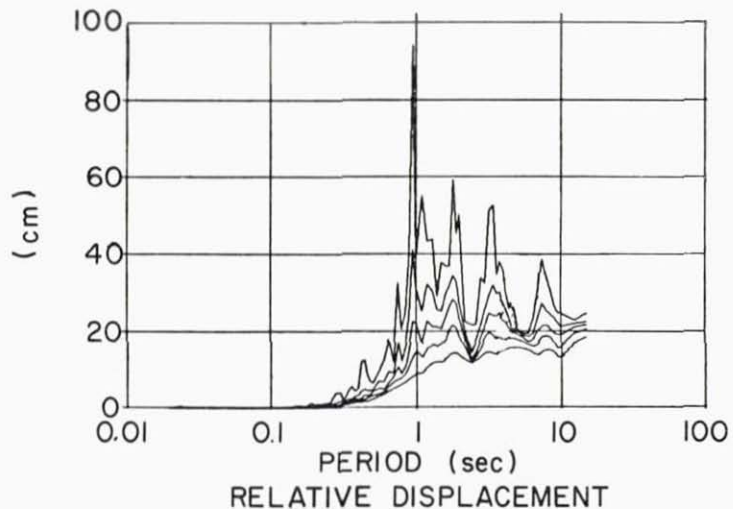
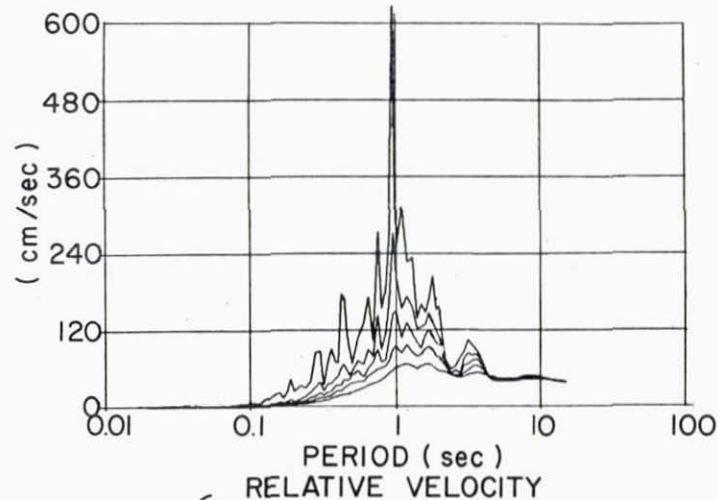
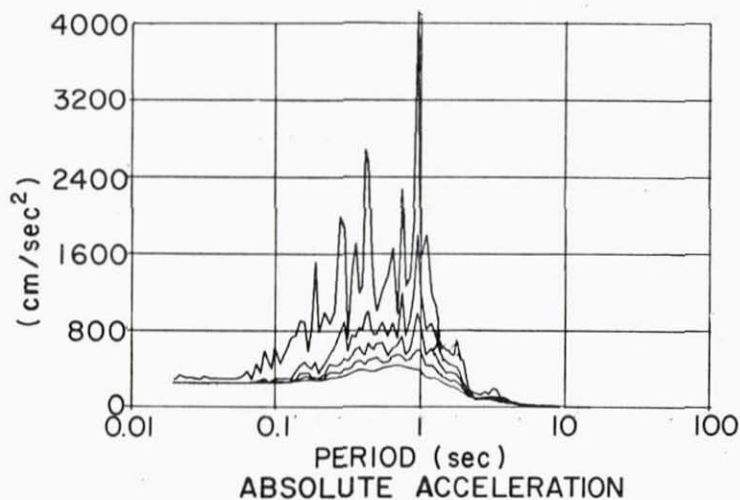

Figure 4.12 Spectra, 1st floor north-south component

TOHOKU UNIVERSITY ENGINEERING BUILDING , JUNE 12, 1978 , 1st FLOOR, EAST - WEST

DAMPING : 0, 2, 5, 10, 20 % CRITICAL

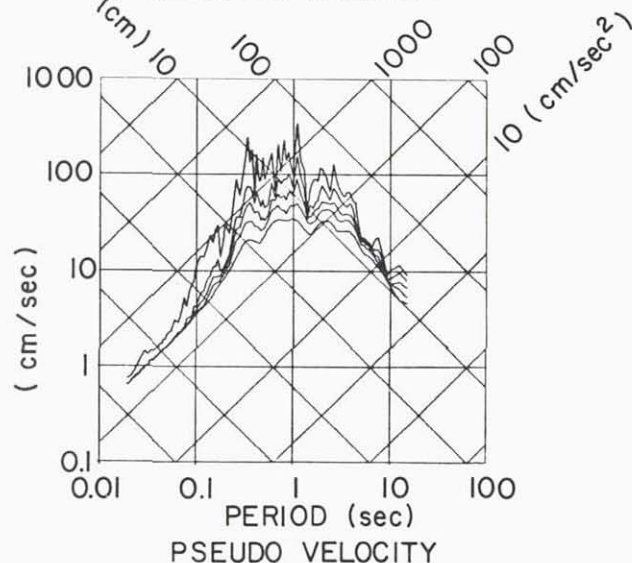
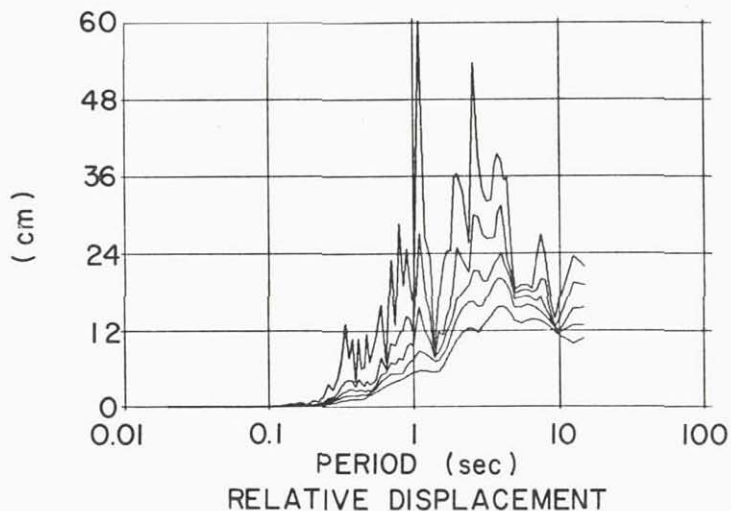
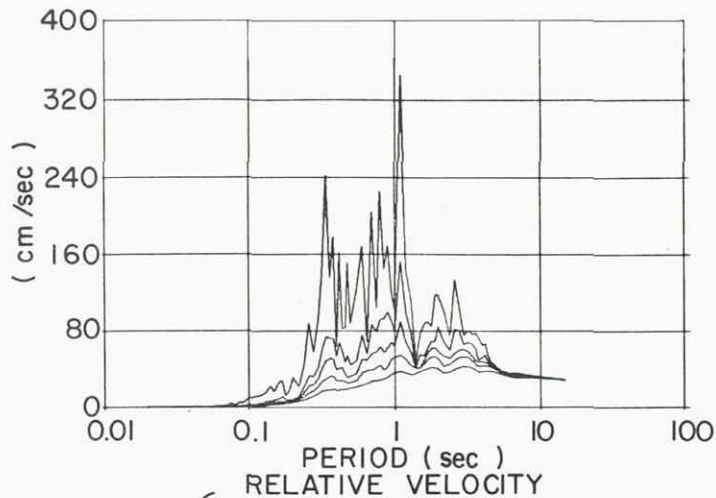
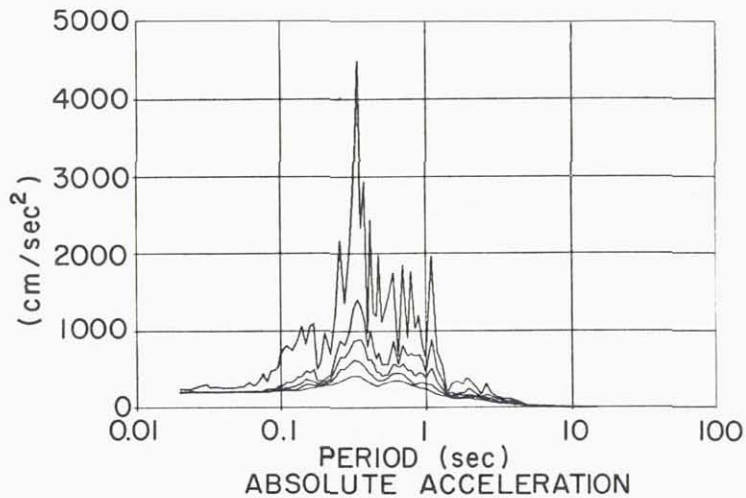

Figure 4.13 Spectra, 1st floor east-west component.

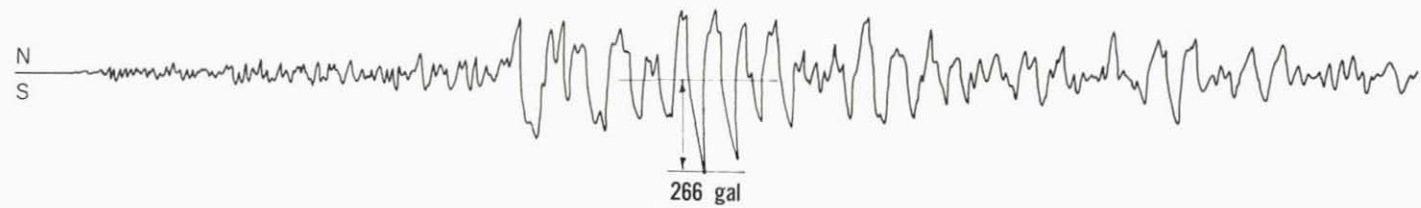
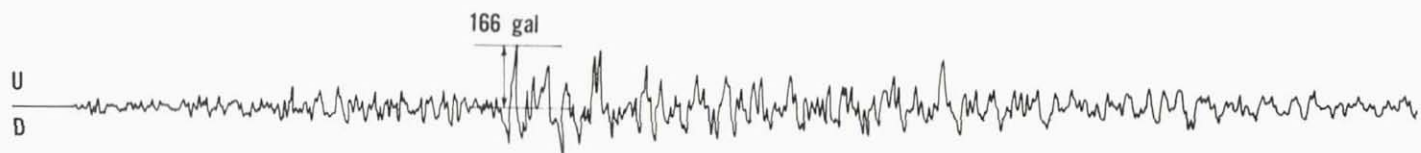
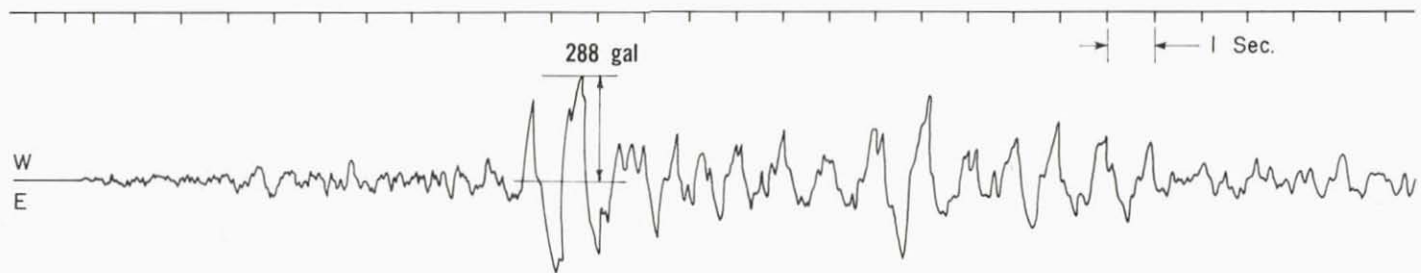

Figure 4.14 Tracing of portion of record from TH033 Shiogama.

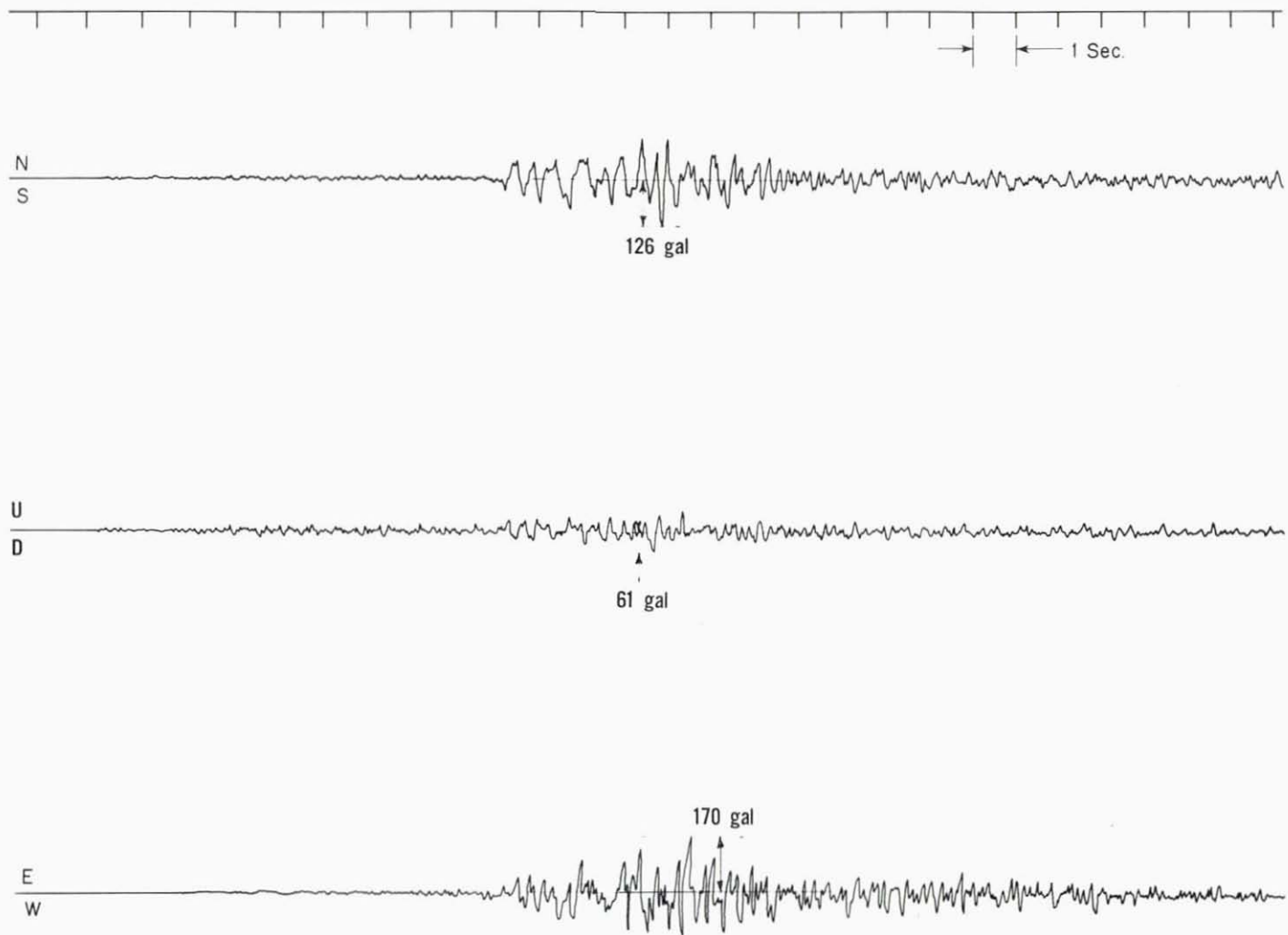

Figure 4.15 Tracing of portion of record from TH019 Ofunato.

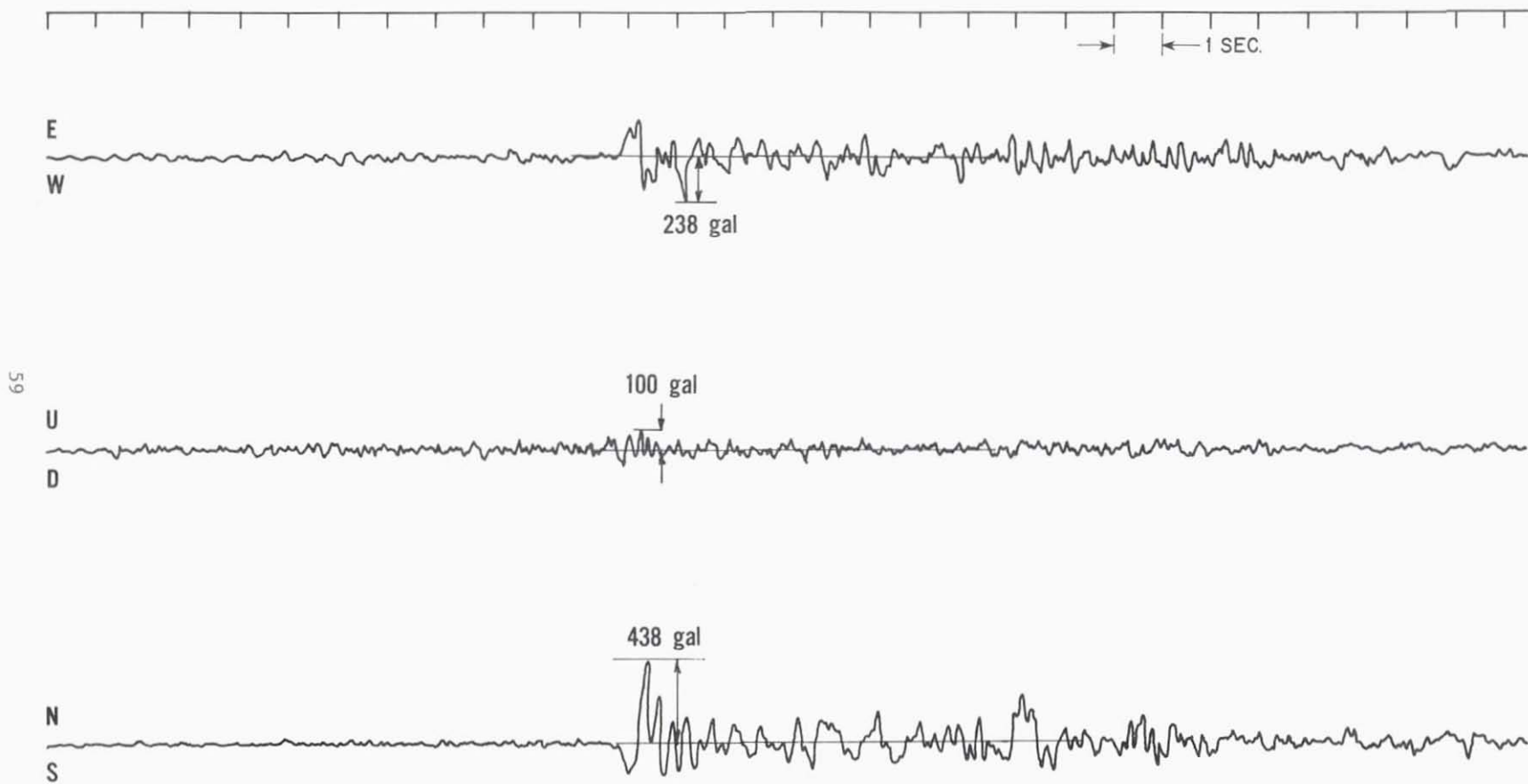

Figure 4.16 Tracing of portion of record from TH018
JNR Building, Sendai, 1st basement.

- 4.5. Kuribayashi, E., Tsuchida, H., and Watabe, M. (1975). Maintenance of the Strong Motion Accelerograph and Data Processing of Records Obtained, Proc. 7th Conference UJNR Wind and Seismic Effects, May 1975, Tokyo, Japan.
- 4.6. Iwasaki, T., Katayama, T., Kawashima, K., and Saeki, (1978), Statistical Analysis of Strong Motion Acceleration Records Obtained in Japan. Proc. 2nd Int. Conf. on Microzonation, November 1978, San Francisco, Calif., USA.
- 4.7. Watabe, M., 1978. Personal communication, and tentative report by Building Research Institute.

5. EARTHQUAKE PERFORMANCE OF BUILDINGS*

5.1 Introduction

As shown in the aerial photograph in Figure 5.1 and in Figure 5.2, Sendai is a large modern city. It is the center for commerce and industry for Miyagi Prefecture. Many buildings in the city can be considered to be modern highrises, in excess of five to six stories. In particular, the downtown center of the city has a multitude of modern buildings in the 10- to 20-story range. The map in Figure 5.3 shows the metropolitan Sendai area; Table 5.1 identifies the points of interests on the map.

The U.S. team arrived in Sendai June 23rd, 11 days after the earthquake. The first impression upon entering the city was that a significant earthquake had not even occurred. This was due in part to the speed with which the Japanese authorities had responded to the disaster. Evidences of damage that would have otherwise impeded the normal operations of the city had already been cleared away. Upon closer inspection, minor facade damage became obvious (Figures 5.4, 5.5, 5.6, and 5.7. This sort of damage was not widespread by any means and numerous modern buildings did not show any damage to their architectural veneers or glazing. It was reported that many chimneys and stacks had collapsed or were severely damaged (e.g., Figures 5.8 through 5.10).

As the investigation proceeded, it became obvious that numerous pockets of damage existed throughout the city. These apparently are correlated to the local geological and soil conditions, discussed in Chapter 3. Soil conditions in the downtown Sendai area (Figure 5.3, within 2 km N and W of the railway station) generally are quite good. Many highrises in this area have raft foundations and are situated on a gravel-type soil. The area to the west and south of the Hirose river are stable terrace deposits. However, the area to the east of the railroad and to the south of Japan National Highway 45 is a former agricultural area. The underlying soil is a young alluvial deposit, and from an engineering point of view, the soil conditions are quite poor.

This chapter begins with an overview of seismic engineering and construction practices in Japan. This will be followed by a discussion of investigations of commercial and retail establishments, schools, apartment buildings, and single family residences. Industrial facilities are covered in Chapter 6.

5.2 Seismic Engineering and Construction Practice

The general seismic design philosophy in Japan is that it is not economically feasible to provide complete protection against all earthquakes. Prevention of loss of life is the overriding concern. Thus, the design criteria are aimed at preventing structural damage and minimizing damage due to moderate earthquakes, and avoiding collapse or serious structural damage due to severe, infrequent earthquakes.

The Japan Building Code governs the design of buildings and related structures such as chimneys and elevated water towers. The method of seismic coefficients is similar in concept to the U.S. equivalent lateral force method recommended by the Uniform Building Code (1976) and other standards. It is still commonly used in Japan, particularly for buildings five stories and less in height, but it is recognized as being unsuitable for many flexible structures. Dynamic analyses are required for buildings over five stories in height.

There are a number of general guidelines and requirements, which are discussed in further detail in Refs. 5.1 - 5.4. For example seismic calculations are required in buildings of more than 100 m² floor area used for schools, hospitals, and places of public assembly, and in structures having more than two stories or 200 m² floor area. No buildings with total floor areas exceeding 3000 m² can be wood, nor can buildings in excess of 13 m in height be wood or unreinforced stone, brick or concrete block masonry, or concrete. There are additional detailing requirements that depend on the construction material.

* Prepared by Bruce Ellingwood, Center for Building Technology, National Bureau of Standards, Washington, D.C.



Figure 5.1 View of the downtown area of Sendai (Tohoku Electric Power Company photograph).



Figure 5.2 Typical buildings of the downtown Sendai area.

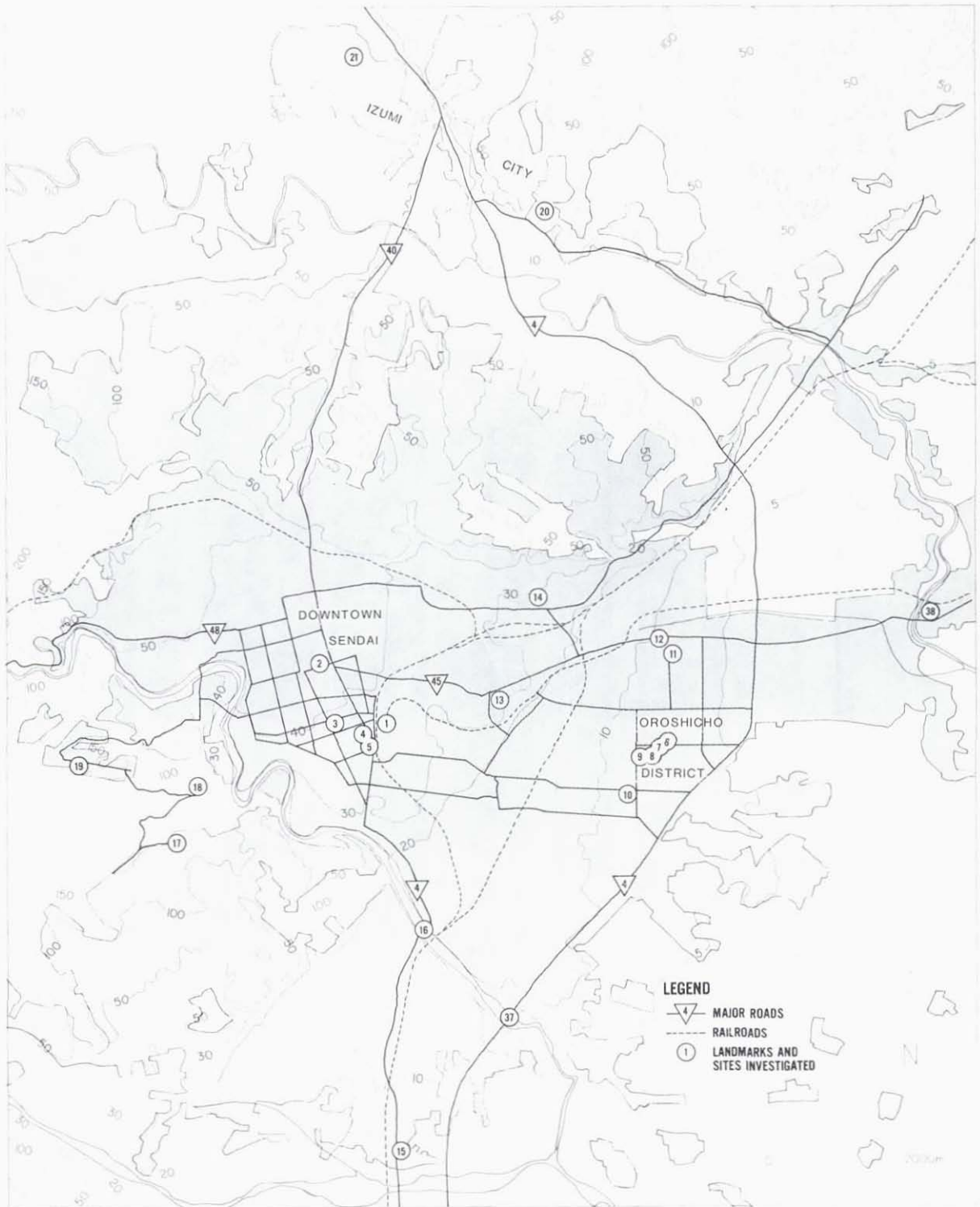

Figure 5.3 Map of Sendai City, showing major landmarks and sites of damaged structures. See Table 5.1 for identification

Table 5.1 - Numbered sites in Figures 5.3 and 6.1

1. Sendai railway station
2. Second government building
3. 77 Bank building
4. Sumitomo Insurance Building
5. Japan National Railway building
6. Maruyoshi building
7. Obisan building
8. Kinoshita building
9. Maruhon building
10. Yazaki Industries
11. Taiyo Fisheries Plant
12. Paloma Sendai building
13. Tonan High School
14. Haronamachi Gas Plant
15. Cement plant
16. Hirose Bashi Bridge
17. Tohoku Institute of Technology
18. Aoba Castle
19. Tohoku University
20. Sendai Substation, Tohoku Electric Power Company
21. Izumi City High School
22. Yuriage Bridge
23. Abukuma Bridge
24. New Sendai Power Plant, Tohoku Electric Power Company
25. Tohoku Oil Company, Ltd. refinery
26. Ono Bridge
27. Kimazuka Bridge
28. Eaigawa Railway bridge
29. Kaihoku Bridge
30. Tenno Bridge
31. Inogawa Bridge
32. Yanaizu Bridge
33. Toyoma Ohashi Bridge
34. Maiya Ohashi Bridge
35. Kin-no Bridge
36. Kitakami Ohashi Bridge
37. Sendai Ohashi Bridge
38. Sunny Heights Apartment building



Figure 5.4 Minami Machidori Building, Sendai. The cracking to the brick veneer is typical for many similar buildings in the city.

Figure 5.5 Minami Machidori Building. Closeup of the lower floors of the building.

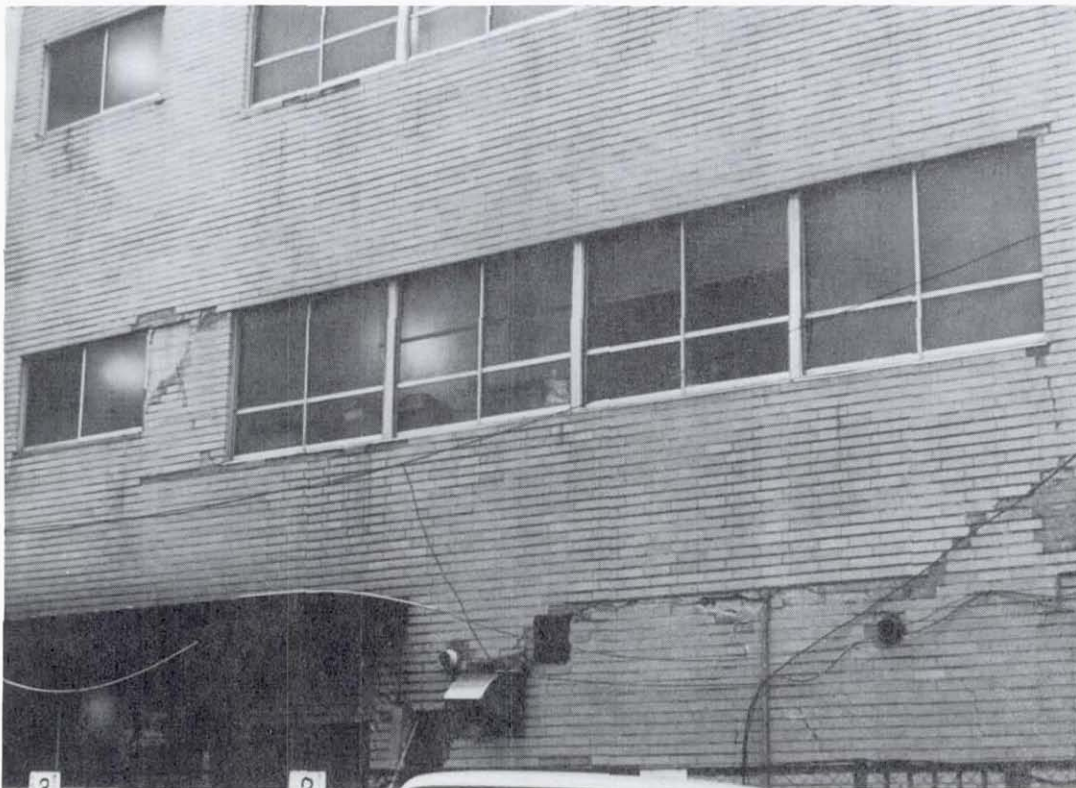



Figure 5.6 Second Eastern Building Company Building, Sendai. A typical modern building in Sendai; the only apparant damage to the glazed tile veneer on the exterior was cracking on spandrels and shear walls.

Figure 5.7 Second Eastern Building Company Building. Closeup of exterior wall.

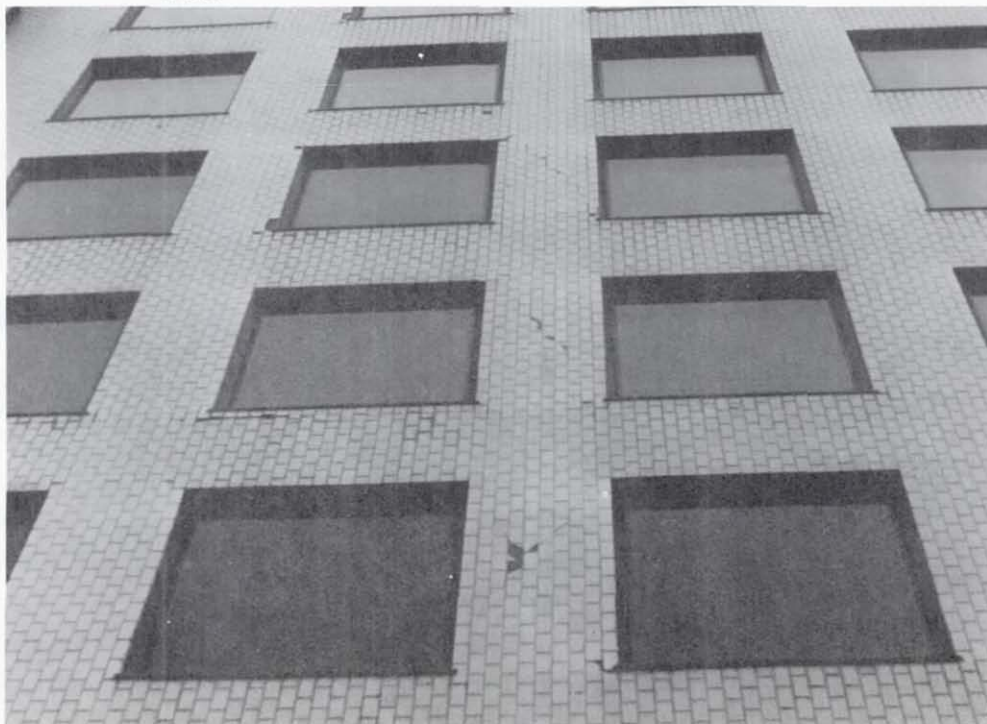



Figure 5.8 Chimney damage to the Mitsukoshi Department store. Numerous such chimneys suffered such damage.



Figure 5.9 Downtown Sendai. Reinforced concrete chimney failure.

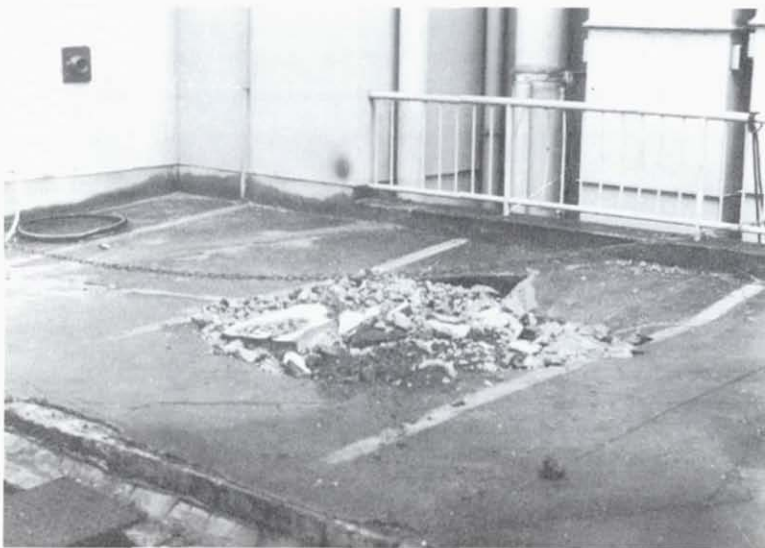

Figure 5.10 Impact area of chimney failure (see Figure 5.9)

The seismic base shear V is calculated by multiplying the sum of dead and a portion of the live load by a seismic coefficient k that is calculated as the product of a standard seismic coefficient k_0 , a site seismicity coefficient k_1 and a soil and building type coefficient, k_2 . Coefficient k_1 is determined from a map, and takes into account the intensity and frequency of earthquakes anticipated for the location. For Sendai and environs, $k_1 = 0.9$. Coefficient k_2 accounts for the characteristics of the ground at the site and the probable mode of behavior of the building. The product of $k_1 k_2$ is in no case taken as less than 0.5.

This procedure is summarized as follows:

$$V = kW$$

W = Dead plus a portion of live load

$$k = k_0 k_1 k_2$$

k_0 = standard seismic coefficient

= 0.2 for heights less than 16m

= $0.2 + \frac{0.01}{4} (h-16)$ for heights greater than 16m

= 0.3 for wood structures on soft ground (alluvium greater than 30m thick, reclaimed marshes, etc.)

k_1 = Site seismicity coefficient (map provided)

k_2 = Soil and building coefficient

Values of k_2

Rock	Wood	Steel	R/C	Masonry
Sand-Gravel	0.6	0.6	0.8	1.0
Sandy Clay	0.8	0.8	0.9	1.0

Note that k_0 varies with the height of the building; however, building period does not enter the seismic force equation explicitly.

The Japan Building Code permits the allowable stresses to be increased by a factor of 100 percent for earthquake, while most standards in the U.S. permit only 33 percent increase. However, U.S. standards (e.g., Uniform Building Code, 1976 Edition) do not include live load in determining W , except for warehouse and storage occupancies. The basic force coefficient k_0 is larger than the factor C in the Uniform Building Code, to which it is analogous.

Unreinforced masonry buildings are generally two stories or less in height. A reinforced concrete collar beam must be provided at the top of each story wall, and the height-thickness ratio of walls must be less than 15.

Earthquake resistance of wooden buildings is generally provided by specifying minimum lengths of walls and diagonal bracing. The Japanese Building Code requires a minimum length of wall or a framework with diagonal bracing for wooden buildings over 50 m² in floor area and two or more stories in height. The required bracing or length of wall depends on the floor area. Bracing must be provided for horizontal floor diaphragms also. These requirements result in a structural frame that is stiffer than those found in single family dwellings in the U.S.

Earthquake resistance in steel buildings is provided either through the use of moment-resisting frames or through diagonal bracing. When braces are used as earthquake resisting elements, it is normal practice to design them so as to carry all of the horizontal force. An example of such a structure is a steel framed furniture warehouse on the outskirts of Sendai shown in Figure 5.11. There were many examples where the bracing members buckled under stress reversal or the connections failed. A number of the transverse diagonal braces used in this warehouse sheared at their bolted cross connections (Figure 5.12).

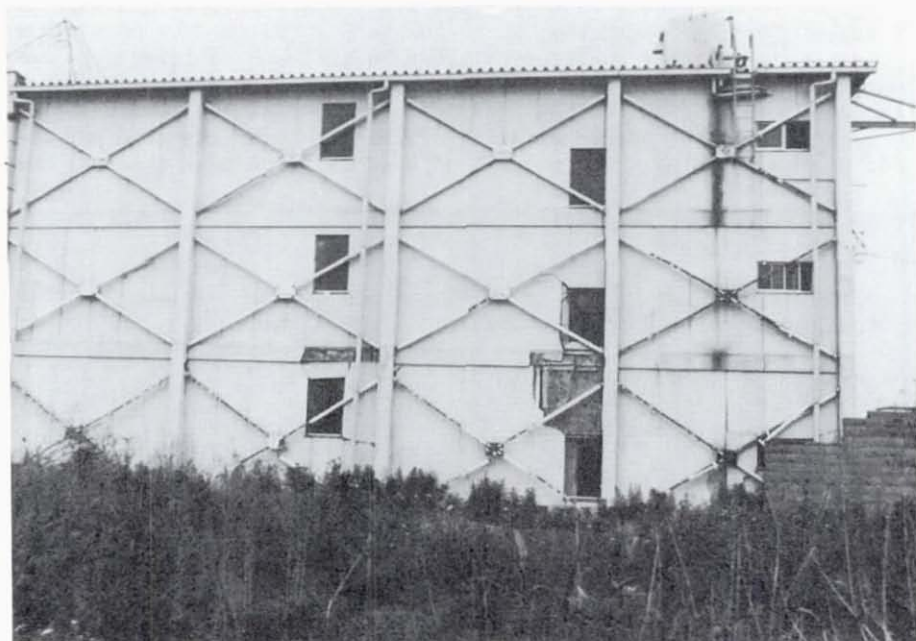
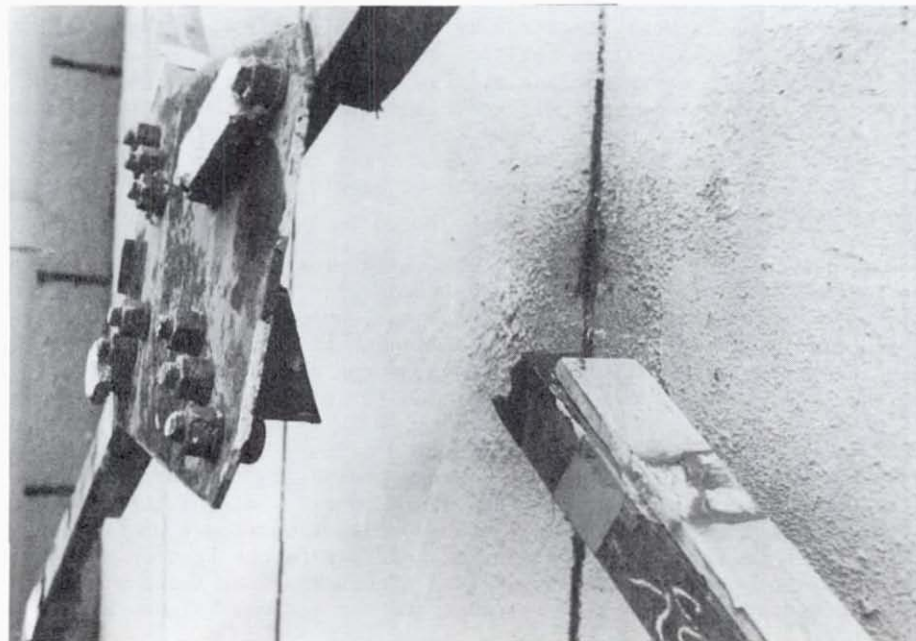

Figure 5.11 A damaged steel-framed furniture warehouse on the outskirts of Sendai.

Figure 5.12 Detail of failure in transverse diagonal braces.



Many modern high-rise buildings in Sendai have steel frames, and these generally performed very well during the earthquake. One example is the Sendai Second Government Building in the downtown area (No. 2 in Figure 5.3), a 17-story structure built in 1973 (Figures 5.13 and 5.14.) The building is situated on a raft foundation, where the underlying soil conditions are good. The frame was designed by dynamic analysis for a maximum base acceleration of 0.2 g. The building is instrumented with strong motion accelerometers at the 15th floor and second basement levels, and a downhole at 40 m below grade. The building suffered virtually no damage, although there was some minor diagonal cracking in the concrete stairwells leading to the basement.

A number of changes were made to the Japan Building Code in 1971, many of which relate to the design of reinforced concrete buildings. While the standard seismic coefficient remained 0.2, requirements for minimum spacing of column ties became more stringent in the 1971 edition. In the pre-1971 code, the maximum tie spacing in normal weight concrete columns was 300 mm or 15 times the diameter of the main reinforcement; in the new code, the maximum spacing permitted is 100 mm. The minimum allowable bar cover is 30 mm. Section A.6.5.3 of ACI Standard 318-77 (Ref. 5.7) and Chapter 11 of Ref. 5.6 have similar requirements that limit vertical spacing of ties in columns to 4 in (100 mm) at locations above and below beam-column connections. Undeformed reinforcing bars were commonly used in Japan until about 10 years ago. The 1971 Japan Building Code requires the use of deformed bars, however.

Numerous modern buildings in Japan, particularly those between six and fifteen stories, use the SRC (Steel and Reinforced Concrete) system, in which the reinforcement is provided by embedded steel shapes in conjunction with conventional reinforcing bars. The fire resistance and safety against buckling are high, while the the cross sectional dimensions of the structural members can be made smaller than in conventional reinforced concrete structures. The systems is quite ductile. The Sumitomo Insurance Building in downtown Sendai (No. 4 in Figure 5.3) is an example of such a structure (Figures 5.15 - 5.17). This is a modern 18-story SRC building with continuous reinforced concrete shear walls around the elevator core and on the outside transverse walls. The interior shear walls around the elevator core and some of the construction joints in the stairwells and nonstructural partitions showed minor diagonal cracking. However, the main structural elements are believed to be undamaged. It was reported that after the February 1978 earthquake, the Sumitomo Insurance building had diagonal cracking in secondary walls and that after the June earthquake, these had become more extensive. Vibration tests conducted before and after the February earthquake showed that the fundamental frequency decreased from 1.2 Hz to 1.0 Hz due to cracking. The structural damping also increased. The Sumitomo Insurance Building had strong motion instrumentation in the 2nd basement, the 9th and 18th floors (see Chapter 4). Peak accelerations of 0.26 g (2nd basement) and 0.56 g (18th floor) were recorded during the June 12 earthquake.

The 77 Bank Building is located in downtown Sendai not far from the train station (No. 3 in Figure 5.3). An exterior elevation and a floor plan are shown in Figures 5.18 and 5.19. The basements and first three stories are SRC, while the remainder has a steel frame. Like many of the high-rises in the main area of the city, it has a raft foundation. As shown in the plan, the building has an eccentrically located elevator core, surrounded with reinforced concrete shear walls. A quick walk-through inspection revealed no signs of damage to interior columns, their stucco panel facing, or the marble veneer in lower story corridors. The building was completed in 1977 (hence its name), and was designed according to the 1971 seismic code.

5.3 Commercial and Retail Establishments

The map of Sendai in Figure 5.3 shows a shaded area east of the railroad tracks and south of Japan National Highway 45. Until about 10 years ago, this was an agricultural area that was mainly rice paddies. The water table is known to be quite high and, from an engineering point of view, the soil conditions are poor. There are numerous buildings in the two- to four-story range which are used for small business, retail, and other commercial establishments. These buildings typically have a ground-story used to display merchandise with large open areas and few walls. The upper floors are used for offices and for storage. This type of building layout creates a structure in which walls are not placed symmetrically with respect to the center of the structure and in which the first-story lateral force-resisting elements are relatively flexible when compared with the upper portions of the structure.



Figure 5.13 Sendai Second Government Building. This modern steel frame structure suffered no damage.

Figure 5.14 Sendai Second Government Building, ground level.



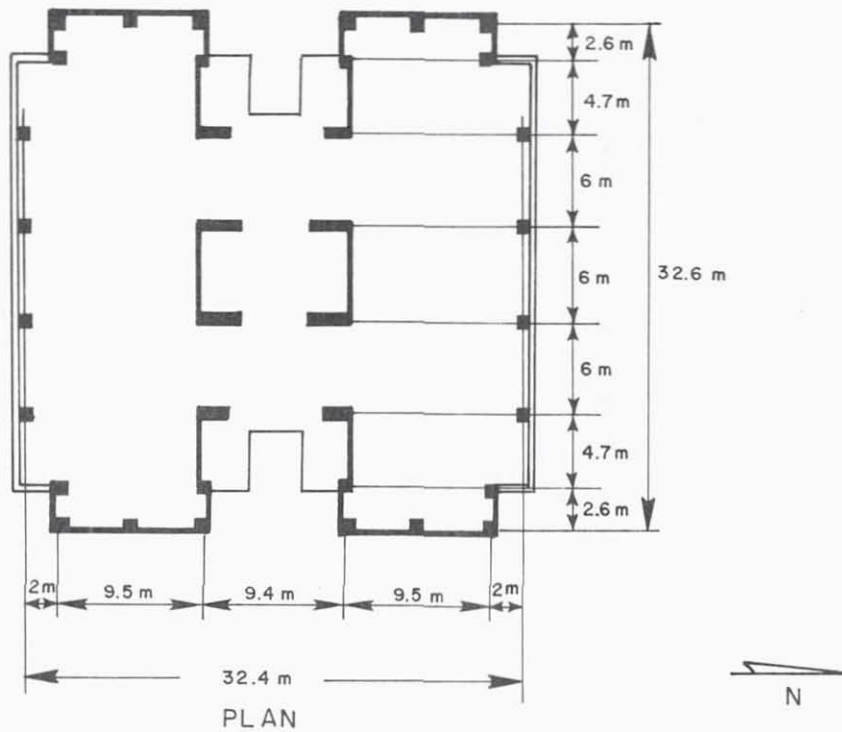

Figure 5.15 Sumitomo Insurance Building, Sendai, plan view. The building has continuous shear walls around the elevator core and on the transverse outside walls.



Figure 5.16 Sumitomo Insurance Building.
Exterior Elevation

Figure 5.17 Sumitomo Insurance Building.
Detail of exterior shear wall.



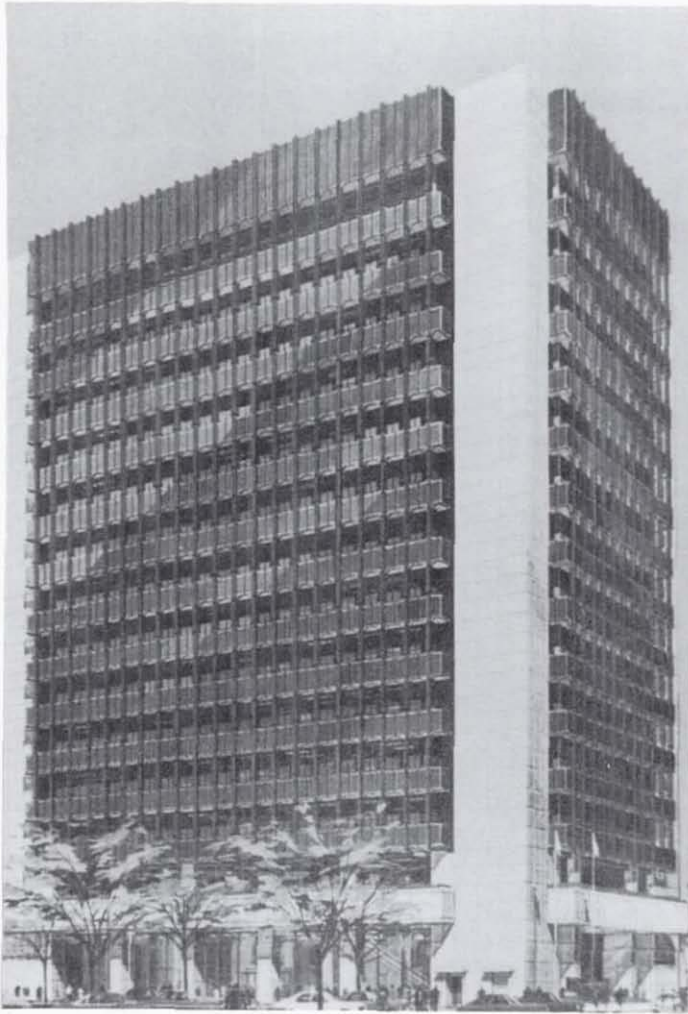

Figure 5.18 77 Bank Building,
Sendai. Exterior
elevation. (company
photograph).

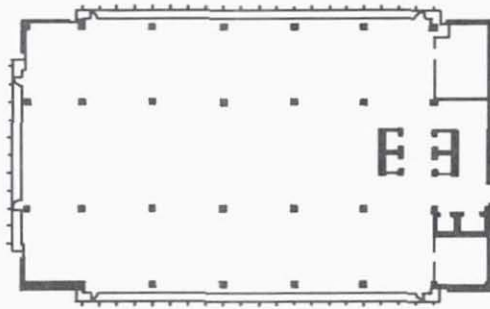

Figure 5.19 77 Bank Building.
Typical floor plan.

In this general area, referred to as Oroshicho, numerous buildings suffered extensive damage and there were several reinforced concrete structures which collapsed. The latter were all in the two to four-story range. Most of the buildings in this area were reported to be built on pile foundations, although no particulars for specific buildings were obtained. The collapsed reinforced concrete structures were all designed and built in the middle 1960's prior to the adoption of the 1971 seismic building code.

There were no acceleration records obtained in this area. However, shaking in the N-S direction apparently was stronger than in the E-W direction, at least in the area visited, since most of the damage observed to buildings resulted from strong motion in the N-S direction.

There was extensive evidence of ground settlement in the Oroshicho area, including settlement of asphaltic concrete sidewalks and slumping around building foundation walls, as in Figures 5.20, and 5.21.

Maruyoshi Building (No. 6, Figure 5.3). This was a three-story reinforced concrete frame building, one span by three, with the long axis of the building running in the E-W direction. There was a 2 m overhang on the north side of the structure (Figure 5.22). The wall shown at the west end was continuous from the second-story on up. The building had a flexible first-story. The building suffered extensive damage to the first-story (Figure 5.23) and, as shown in Figure 5.24 was tilting toward the north. The first story columns on the south side of the building failed in shear due to the strong N-S motion. A detail of the beam-column joint where the second-story floor beam frames into the first-story column is shown in Figure 5.25. Column ties appeared to be spaced at about 300 mm. The shear wall on the west end of the structure appeared to be undamaged. Unfortunately, this caused the structure to behave as an inverted pendulum and caused the first-story columns to accept even more shear. Note the use of the undeformed bars in the beam-column joint (Figure 5.25).

The building was being demolished at the time it was visited.

Obisan Building (No. 7, Figure 5.3). This was a three-story reinforced concrete frame building with one span in each direction (Figure 5.26). The portion of the building which overhung the column line by about 2 m contained a heavy stairwell. There were no openings in the overhanging part of the building, which added to the eccentric mass. Coupled with the strong N-S motion, this caused a failure in torsion as the columns at the west end of the building were unable to withstand the forces resulting from the large eccentric mass. Figures 5.27 and 5.28 show the Obisan Building after the earthquake viewed from the north and south, respectively. It may be observed that the upper stories rotated almost as a rigid body when the first floor columns failed. The first-story of the building had been used as a display area, and was completely open. A detail of the SE column is shown in Figure 5.29 and in the plan. As shown in Figure 5.30, the first floor support beams were practically resting on the ground at the west end of the building. The walls above the first-story suffered extensive cracking during the earthquake, but remained intact (Figure 5.31). The reinforcing bars that can be seen are undeformed.

Kinoshita Building (No. 8, Figure 5.3). This three-story reinforced concrete frame building, two spans by six, had its main axis in the N-S direction. As shown in Figure 5.32, there was extensive diagonal cracking on the east face. The first floor on the west side of the building, Figure 5.33, was used as a showroom. Unlike the backside of the building, where the columns were stiffened by spandrels, the columns on the west side were relatively flexible, and there appeared to be very little damage on that side of the building. The brick facing on the west side remained intact. The interior columns on the east side of the building showed large shear cracks and buckling of exposed undeformed bars. A reinforced masonry partition wall also failed here. It is apparent that most of the seismic force was attracted to the relatively stiff east side of the building. In addition, there appeared to be significant settlement of about 100 - 150 mm in the interior of the building on the east side. This, along with the relative stiffness of the east face, would explain the diagonal cracking pattern observed on the east face as well as cracking patterns observed in columns and panels. Failures of this sort were also observed following the Niigata earthquake (Okamoto, 1973).

Maruhon Building (No. 9, Figure 5.3). This six-story reinforced concrete frame building is located one block west of the Kinoshita Building. There was a construction gap of approximately 30 mm between the two parts of the building and no evidence of pounding. There is



Figure 5.20 Oroshicho area, Sendai.
Ground settlement.

Figure 5.21 Oroshicho area. Sidewalk damage
caused by ground settlement.

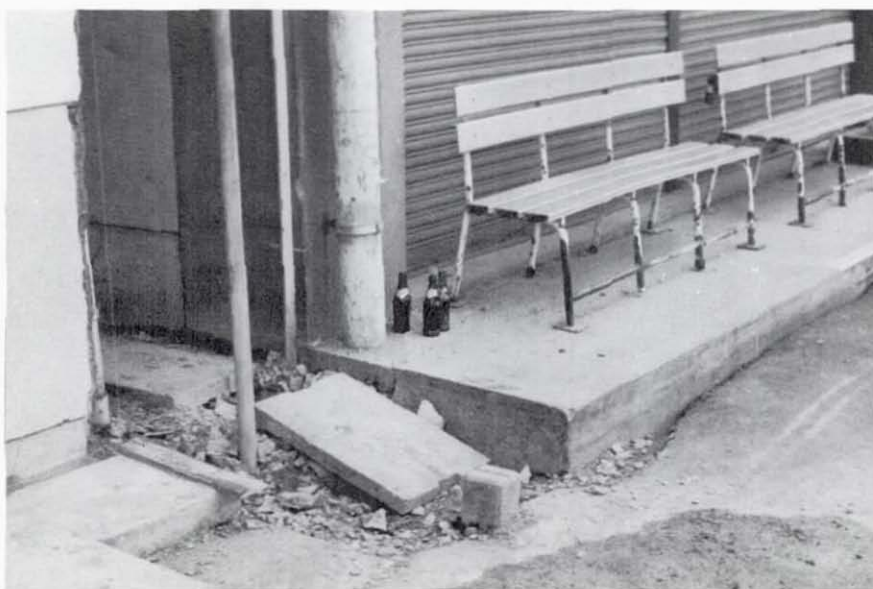

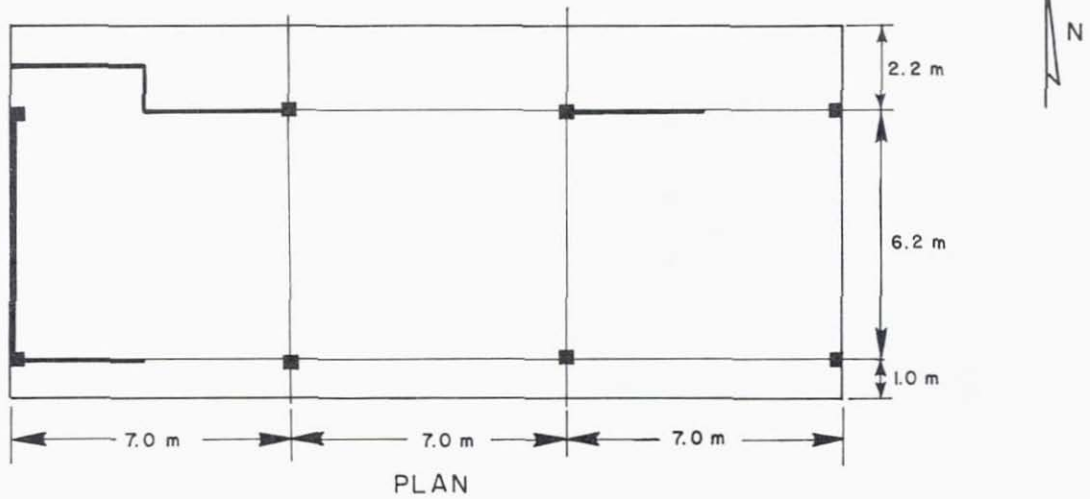

Figure 5.22 Plan view of Maruyoshi Building, Oroshicho area. Note overhang to the north.

Figure 5.23 Maruyoshi Building, view from the northwest. This three story reinforced concrete frame, one span by three, suffered almost total collapse of the first floor.

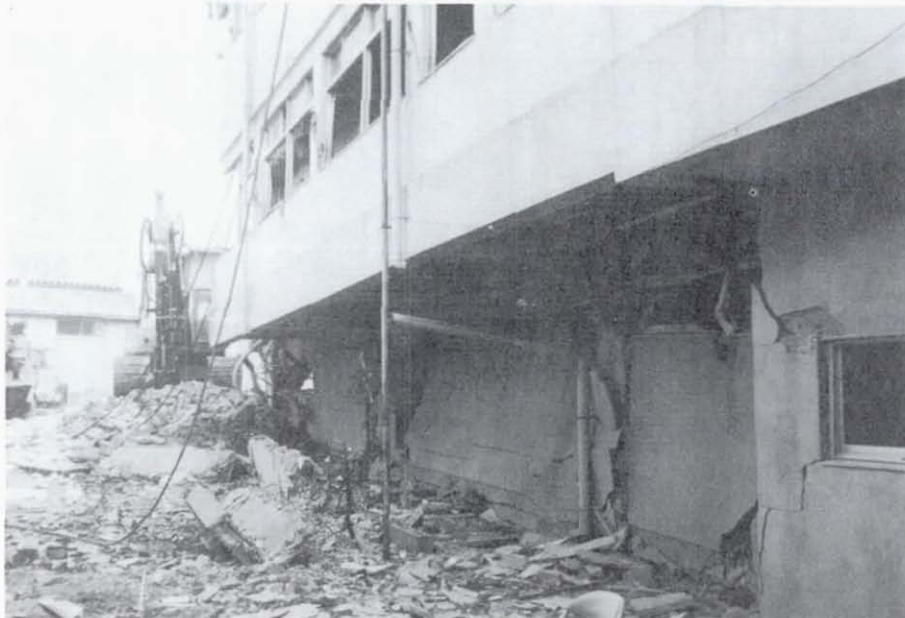



Figure 5.24 Maruyoshi Building, view from the east. Failure of first story columns occurred in shear.

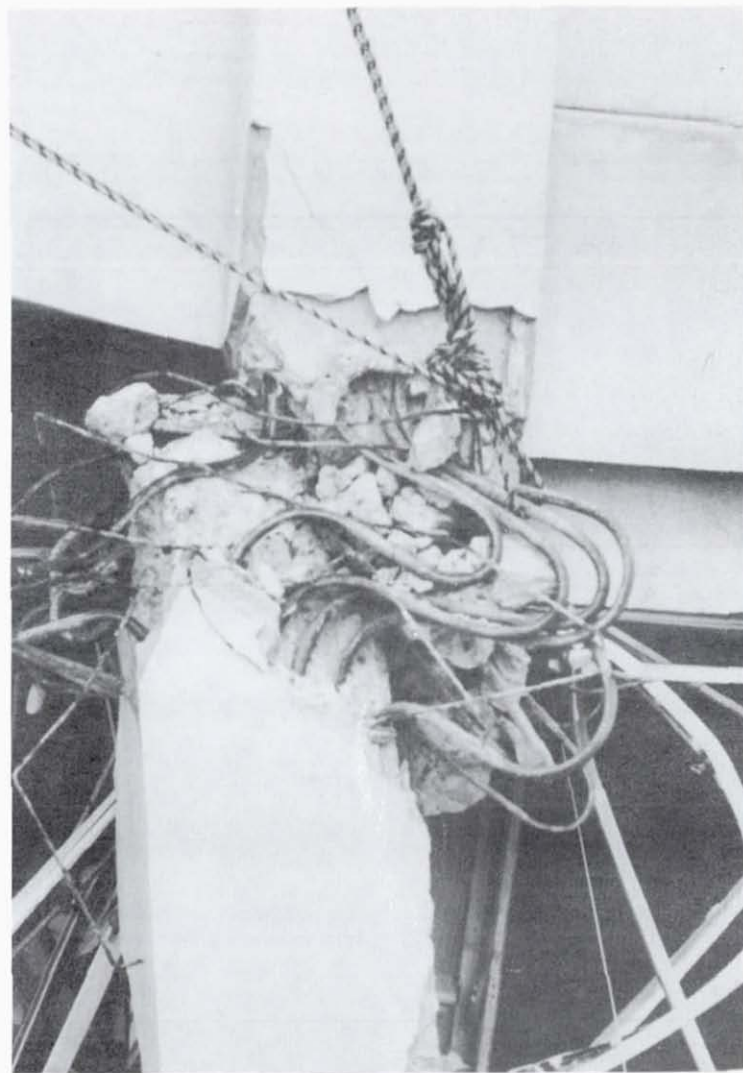
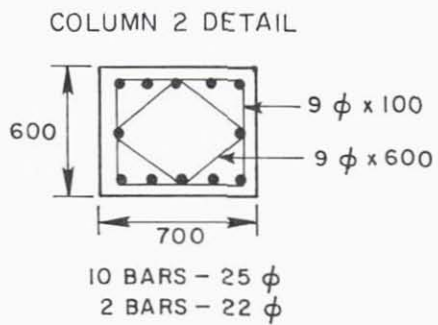
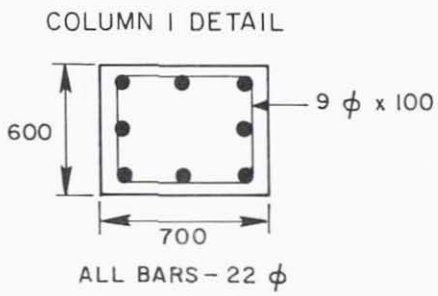
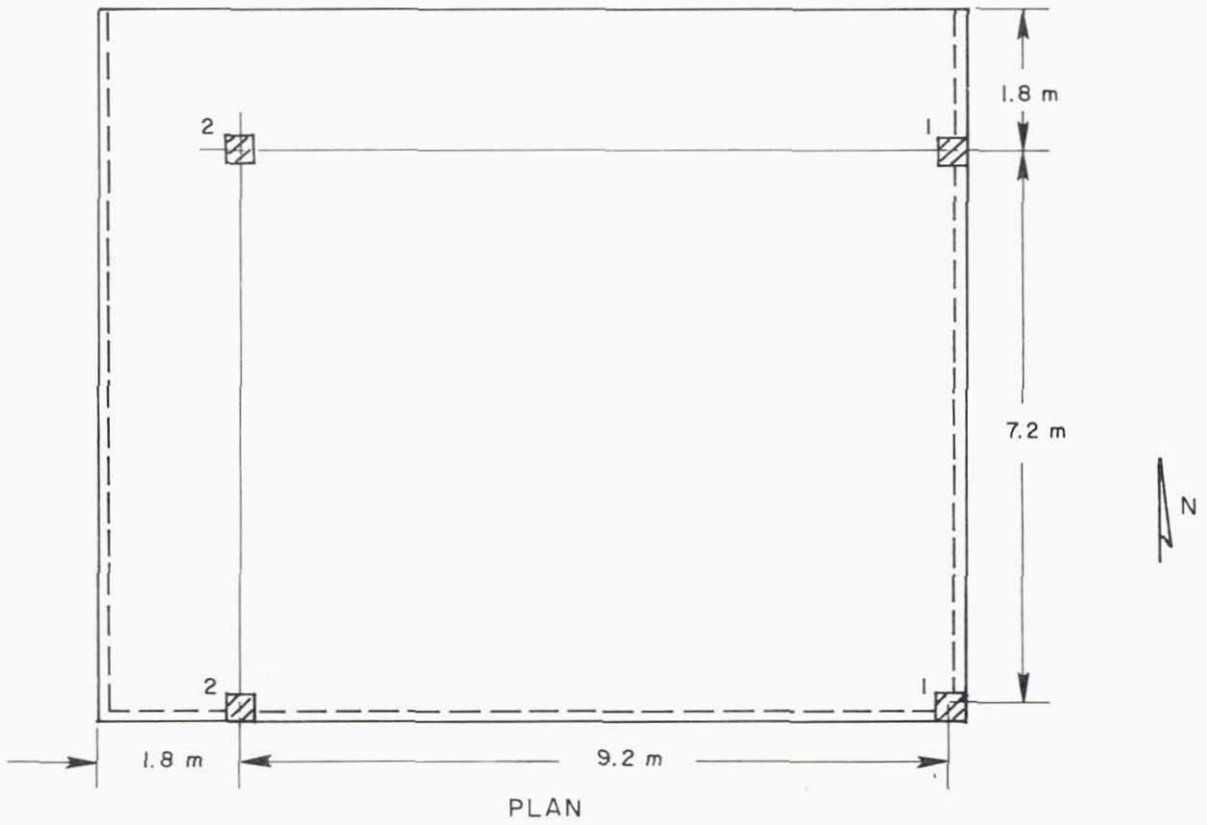

Figure 5.25 Maruyoshi Building. Detail of a joint at the top of a first story column.



DETAILS (ALL DIMENSIONS IN MM)

Figure 5.26 Plan and column details of Obisan Building, Oroshicho area.



Figure 5.27 Obisan Building, viewed from the North. This three story reinforced concrete frame building had a heavy eccentric stairwell cantilevered over the column line at the right end of the building.

Figure 5.28 Obisan Building, viewed from the south. The upper stories rotated as a rigid body when the first floor column support was lost.



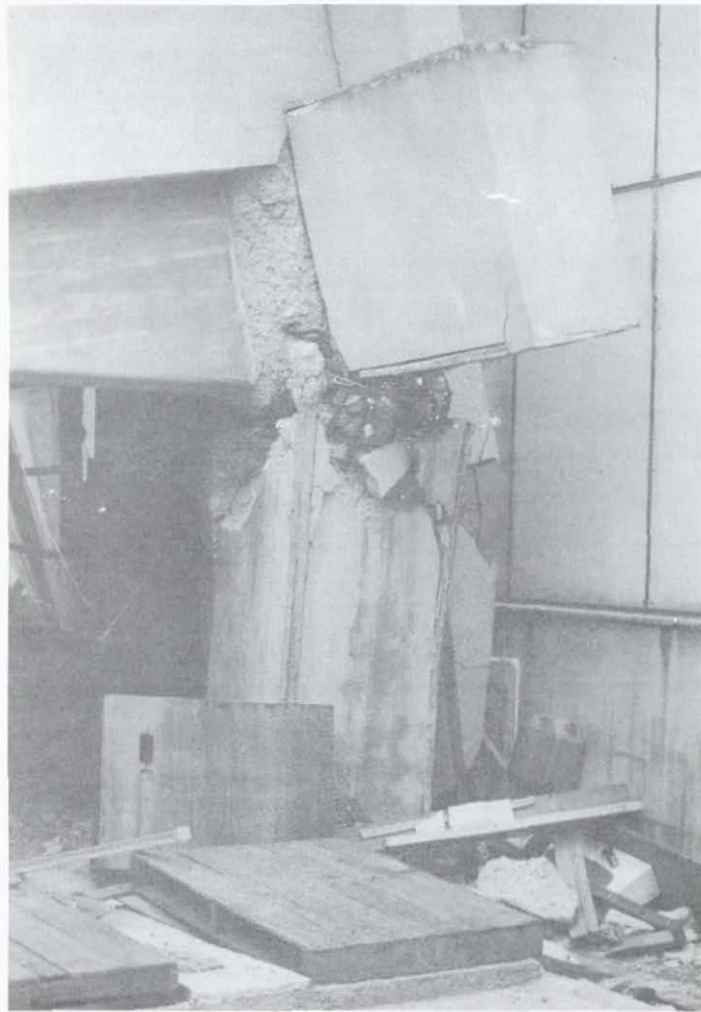

Figure 5.29 Obisan Building, detail of southeast column.

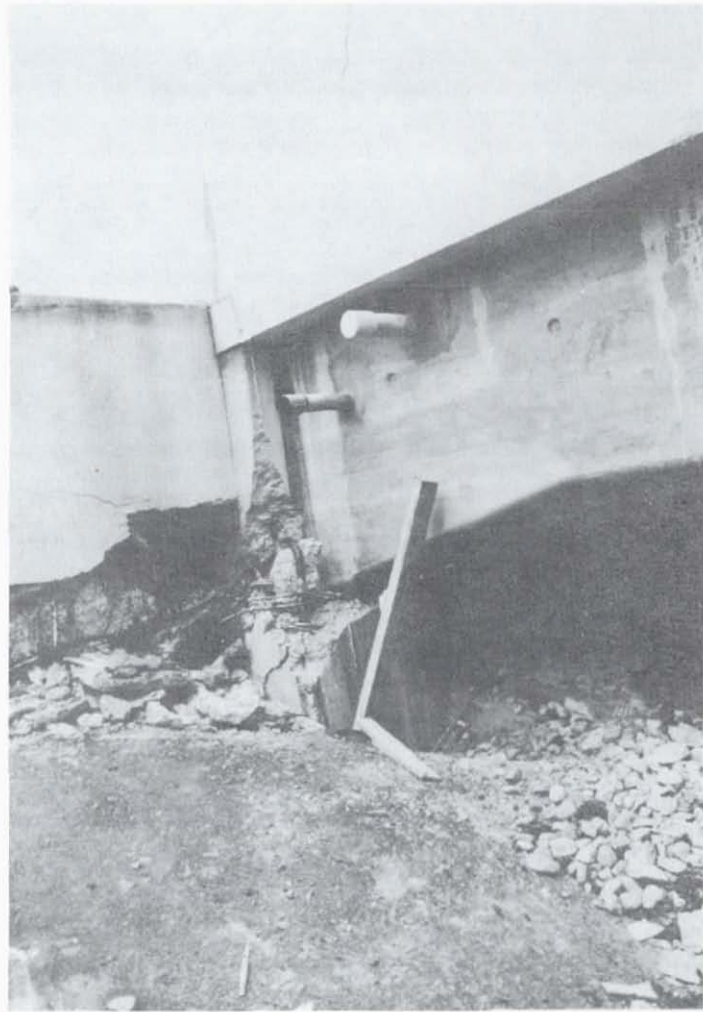

Figure 5.30 Obisan Building, detail of southwest column adjacent to overhang.



Figure 5.31 Obisan Building, south face. Walls above first story remained essentially intact.



Figure 5.32 Kinoshita Building, Oroshicho area, of Sendai. Extensive diagonal cracking was observed on the east face (rear) of the building.

Figure 5.33 Kinoshita Building. The brick facing on the west side of the structure showed little sign of damage.



extensive diagonal cracking in the panels between window openings on both east (Figure 5.34) and west faces (Figure 5.35); this damage is especially severe on the west face, as shown in the detail in Figure 5.36. The decorative ceramic brick facing on the north side of the building did not appear to be damaged.

Despite the level of damage in the Oroshicho area, many buildings performed quite well. As an example, Figure 5.37 illustrates a 9-story building which was only slightly damaged. No details about its construction are known.

Yazaki Industries (No. 10, Figure 5.3). Figure 5.38 shows portions of the three Yazaki buildings. The building on the left has a steel frame with diagonal bracing used as a warehouse. The middle building (tilted) has a four story reinforced concrete frame, 3 spans by 5, which was used as an office building. It was built around 1970. The design acceleration was 0.2 g. The two-story building on the right, a steel frame completed in 1973, was used as a showroom. The buildings are aligned in the N-S direction.

The strong N-S component of the earthquake caused shear failures in the first story concrete columns in the middle building and a collapse at the ground story, causing the entire building to tilt north. This racked the two-story steel frame building forward, causing extensive damage to the steel frame and popping glass panes from showroom windows. The area of impact between the two buildings is shown in Figures 5.39 and 5.40 and 5.41. Figure 5.42 shows a detail of the beam-column joint at the top of the first-story column on the east side of the middle building. The column shear failure extended up into the beam. A detail of the column on the northeast corner of the middle building in Figure 5.43 shows the gross vertical displacement and badly distorted bars in the columns. Unlike the other collapsed buildings in the Oroshicho area, deformed reinforcing bars were used in the Yazaki building. The building service systems between the two impacted buildings were damaged.

The steel frame warehouse behind the collapsed building (Figure 5.38) did not appear to be damaged. The warehouse contained numerous heavy tubular steel frame storage racks with diagonal braces, as shown in Figure 5.44. The storage racks stand approximately 7 m in height and are anchored to the concrete floor by being bolted or welded to steel plates in the floor. Although none of the racks had collapsed, the bottom diagonal braces appeared to have buckled on several racks, as shown in Figure 5.45.

On an adjacent site to the south of the warehouse, there are two five-story reinforced concrete frame apartment buildings with shear walls oriented in the N-S direction. There was no apparent damage to either of these buildings, one of which is shown in Figure 5.46.

Paloma Building (No. 12, Figure 5.3). This reinforced concrete frame structure faced north and was located on Japan National Highway 45. It was a three-story rectangular building, two spans by three, with a shear wall on the west end of the building. The first floor was used for display, and had a large open area on the north and east side of the first floor. The main axis of the building ran in the E-W direction. Figures 5.4 and 5.48 show the Paloma Building viewed from the east following the earthquake. Failure occurred in the columns at this end of the building, causing the building to tilt toward the east. However, the shear wall at the west end of the building was also badly damaged (Figures 5.49 and 5.50). It is likely that the eccentricity caused by the presence of the shear wall on only one end of the building caused a torsional mode of failure for the structure.

The exposed reinforcing bars in the columns were undeformed. The columns at the east end measured 500 mm by 500 mm. The column ties were 9 mm in diameter and were spaced at 300 mm, at least where the reinforcing was exposed. There was less than 25 mm concrete cover for the reinforcing bars in many instances. We were informed that this building was completed in 1963, making it one of the oldest buildings investigated.

Taiyo Fisheries Plant (No. 11, Figure 5.3). This was a three-story building with a reinforced concrete frame, one span by five, the main axis of which was in the N-S direction. There were shear walls on the north and south ends of the structure. As shown in Figures 5.51 and 5.52, the first-story columns in the middle of the building failed, causing the central portion of the building to collapse but leaving the ends standing. The shear walls at the north end of the structure (running in the E-W direction) were badly cracked. At the time the site was visited, the building was being demolished.



Figure 5.34 Maruhon Building, Oroshicho area, showing shear cracking in the panels on the east face between window openings.

Figure 5.35 Maruhon Building, west face, showing cracking of curtain wall panels.





Figure 5.36 Maruhon Building, west face. Detail of the damage to panels between windows.



Figure 5.37 A slightly damaged 9 story building in the Oroshicho area of Sendai.



Figure 5.38 Yazaki Industries Buildings, viewed from the northeast, Oroshicho area. Portions of three Yazaki buildings are shown. Failure of the reinforced concrete middle building caused it to rack forward against the front steel structure.

Figure 5.39 Yazaki Industries Building, viewed from the east.

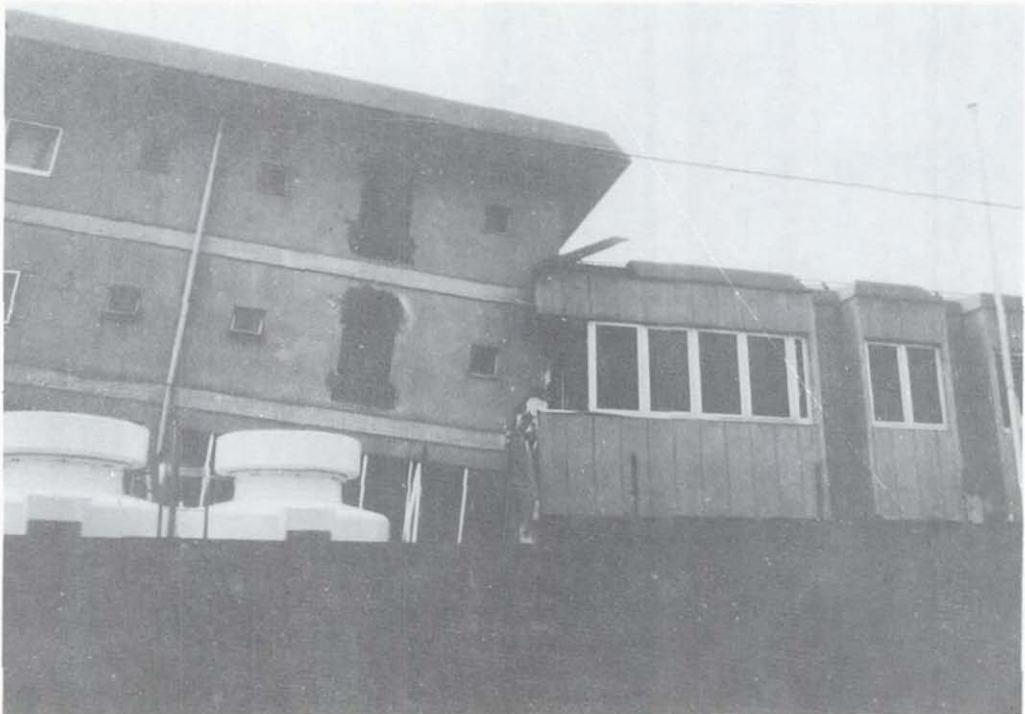



Figure 5.40 Yazaki Industries, showing area of impact between steel and reinforced concrete frames.



Figure 5.41 Yazaki Industries, showing damage to lower story reinforced concrete column.

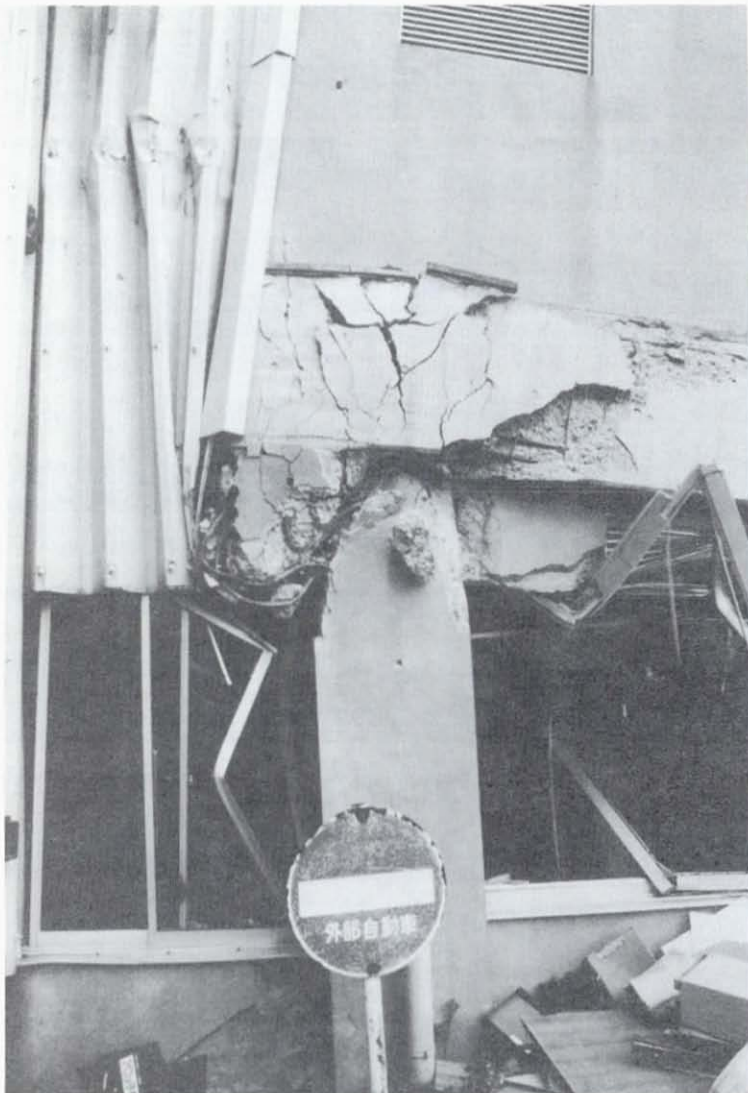

Figure 5.42 Yazaki Industries Building, showing beam-column joint at top of first story column, east side.



Figure 5.43 Yazaki Industries Buildings. Detail of column shear failure, east side. Note use of deformed bars.

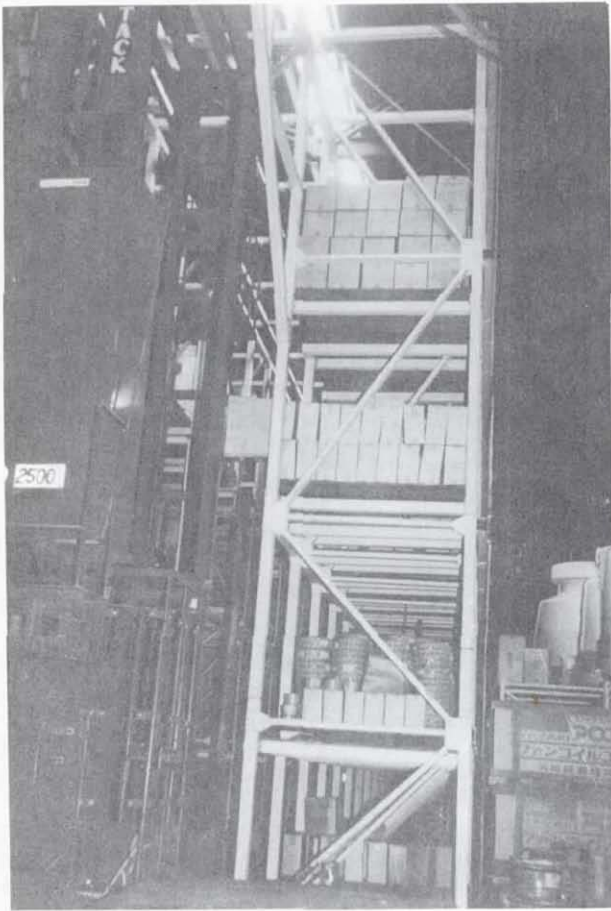

Figure 5.44 Yazaki Industries warehouse building. A number of multi-level tubular steel storage racks had damaged transverse braces at ground level.

Figure 5.45 Yazaki Industries warehouse. Detail of diagonal brace at bottom of storage rack.

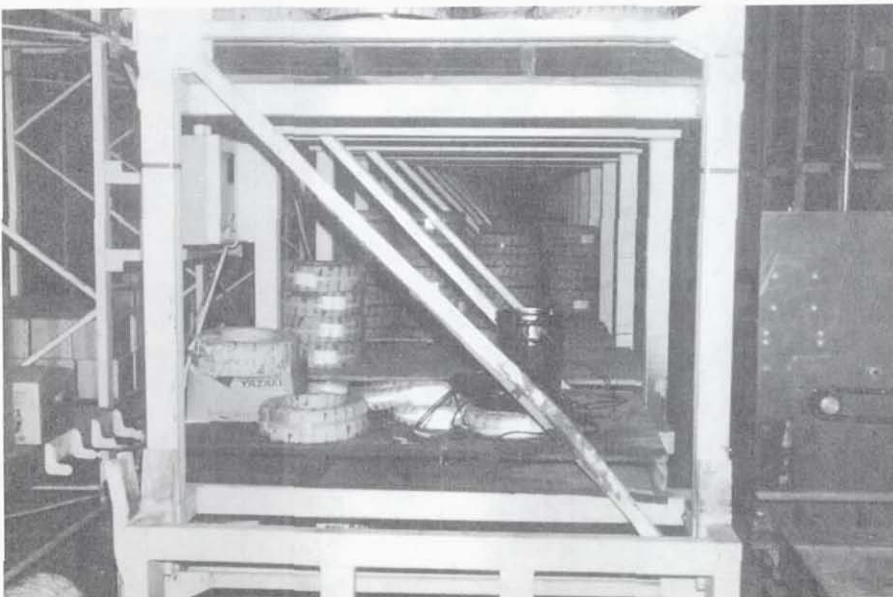



Figure 5.46 Apartment building adjacent to Yazaki Industries warehouse building to the south. The building was undamaged.

Figure 5.47 Paloma Building - Viewed from the east. Collapse occurred at the east end of the building.



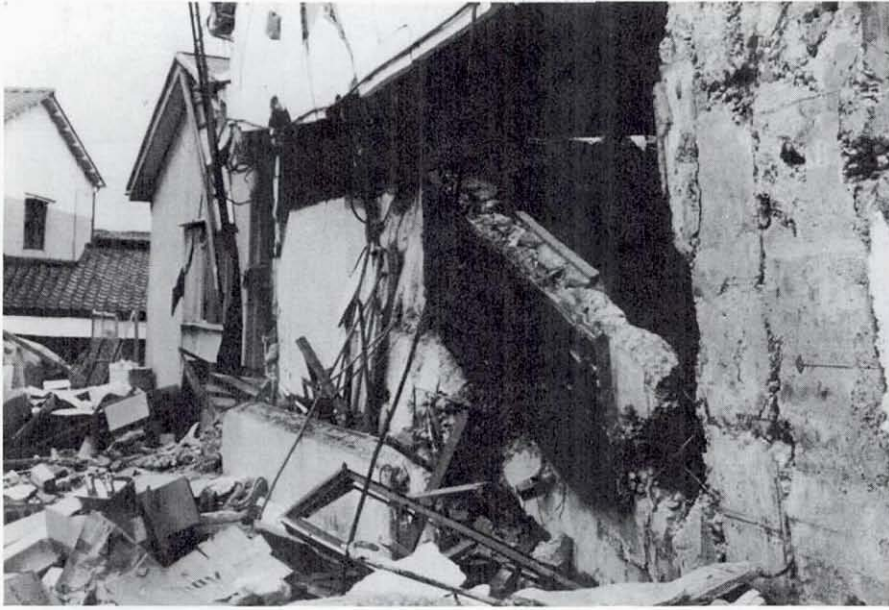

Figure 5.48 Paloma Building. - Detail of first story, east end, showing inferior quality concrete.



Figure 5.49 Paloma Building, west face.



Figure 5.50 Paloma Building, detail of shear wall on west end of building.

Figure 5.51 Taiyo Fisheries Plant, viewed from the west. The first story columns in the center portion of the building failed, leaving the ends of the building standing. (Japan National Land Agency photograph)



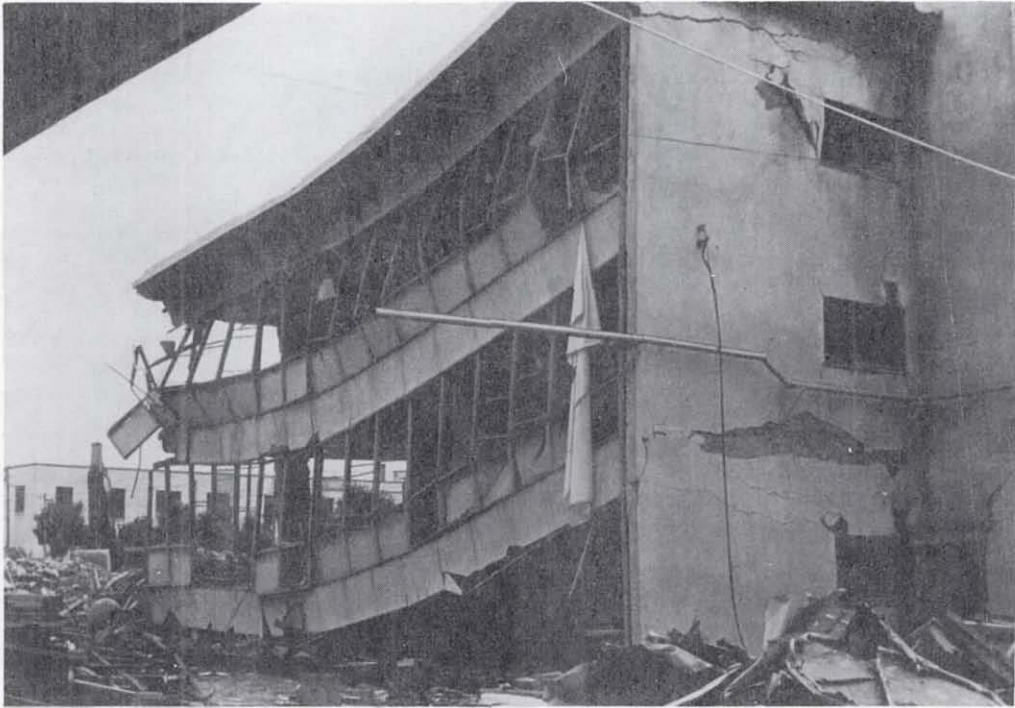

Figure 5.52 Taiyo Fisheries Plant, viewed from the northeast. The reinforced concrete shear wall on the north end was badly damaged.

5.4 Schools

Four schools and university campuses were visited: (1) Tonan High School (two buildings), (2) Izumi Prefectural High School (four buildings), (3) Tohoku University, and (4) Tohoku Institute of Technology (two buildings). As may be seen from the map in Figure 5.3, these facilities are spread out over the Sendai metropolitan area, and they represent only a small percentage of the total number of school buildings.

Tonan High School (No. 13, Figure 5.3). This was a three-story reinforced concrete frame building oriented in the N-S direction with shear walls in the E-W direction. The school was built about 12 years ago using the pre-1971 code.

The school is located on the east side of the city where the soil conditions are relatively poor. The east side of the building sits on a small bluff approximately 6 m in height. This may have amplified the ground motion at the site. The school was badly damaged by the earthquake and has been closed.

The west face elevation and the school yard are shown in Figures 5.53 and 5.54. The exterior first-story columns were all severely damaged, the shear cracks occurring just above the infill panels, (Figures 5.55 and 5.56). In many cases the width of the cracks was over 20 mm. The upper story columns showed less shear cracking. The interior columns did not appear to be damaged. They lacked the stiffening provided by the infill panels. A corridor ran along the length of the building in the middle, and the shear walls were not continuous across the width of the building. Undeformed reinforcing bars were used in the columns. The ties in the exterior columns were spaced at roughly one-half the maximum dimension of the column.

Much of the damage at Tonan High School may be attributed to the unfavorable orientation of the shear walls with respect to the direction of strongest shaking (N-S). A building adjacent to the school but oriented perpendicular to it, which was constructed about the same time and in which the shear walls run in the N-S direction, was undamaged, aside from a few broken windows.

Izumi High School (No. 21, Figure 5.3). The school campus is located in the suburb north of Sendai, approximately 2 km from the Tohoku Electric Power Company Substation, which is discussed in Chapter 7. The buildings were completed in 1973, and their design was based on the 1971 building code. The school was occupied at the time of our visit. Several other schools in the same general area, also designed according to the new standard, suffered less damage than Izumi High School. We were informed that relative to Tonan High School, the soil conditions at the Izumi site were better.

The building plan in Figure 5.57 shows three interconnected classroom buildings, and a steel frame assembly hall (auditorium or gymnasium). The steel frame building appeared to be only lightly damaged from the outside. The classroom buildings are three-story reinforced concrete frame structures with transverse shear walls (not shown, but coinciding with the end classroom walls and stairwells). Classroom corridors extend along the north side of each building.

Figure 5.58 shows the east elevation of the three classroom buildings, and Figure 5.59 shows the front entrance on the north side of building 1. The badly cracked panel above the entrance is not connected to the ground floor. The interior corridor walls in the building had extensive diagonal cracks, as shown in Figure 5.60. Figure 5.61 shows the northeast corner of building 2 along the foundation. The diagonal crack at the corner of the exterior wall indicates that either uplifting or settlement of the foundation took place. Figures 5.62 and 5.63 show typical damage on the north and south sides of one of the classroom buildings. Damage was relatively greater on the north side of the building where the columns were stiffened by the infill panels. Although there were numerous diagonal cracks emanating from window openings on the north side, the main columns did not appear to be badly cracked.

Note from Figure 5.57 that the interior shear walls do not run the width of the building, as they are interrupted by the corridor on the north side of the building. The cracking was less severe on the open side of the building, where the shear walls connect to the columns.



Figure 5.53 Tonan High School, west face. A small bluff on the opposite side of the building may have amplified ground motion. The adjacent structures were undamaged.

Figure 5.54 Tonan High School - Detail of damage to west face.

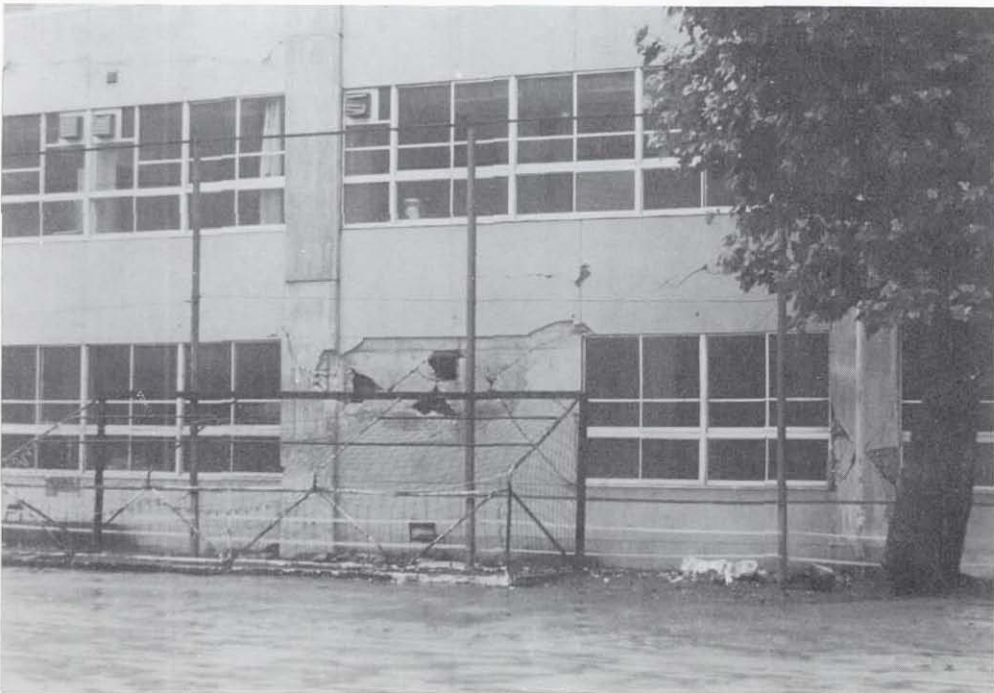

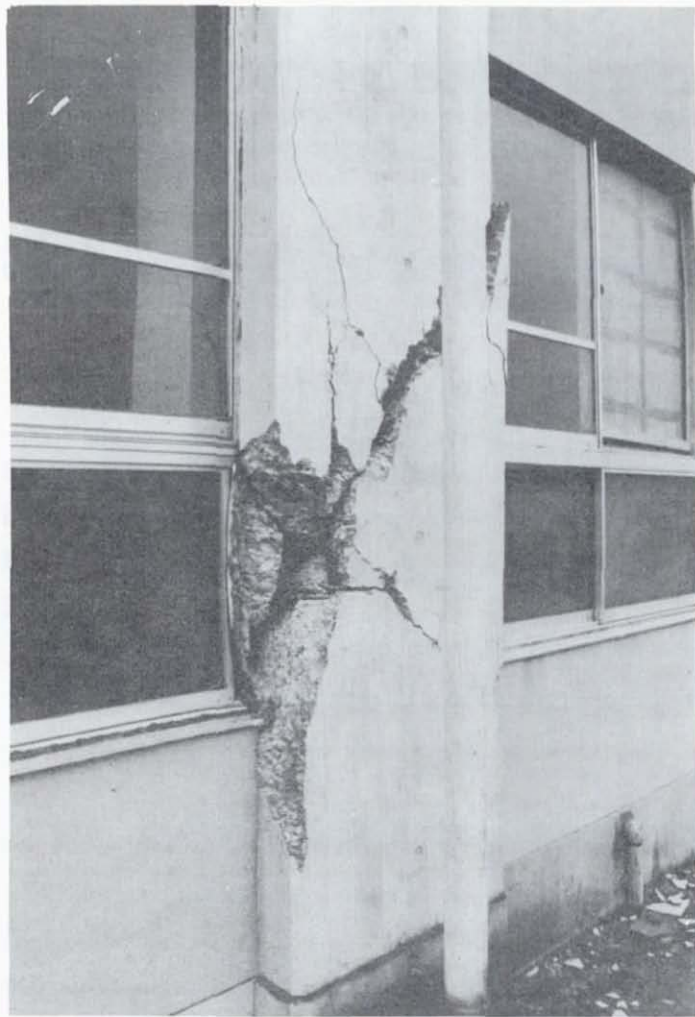

Figure 5.55 Tonan High School. Detail of shear cracking in exterior column above partial infill panels on east face

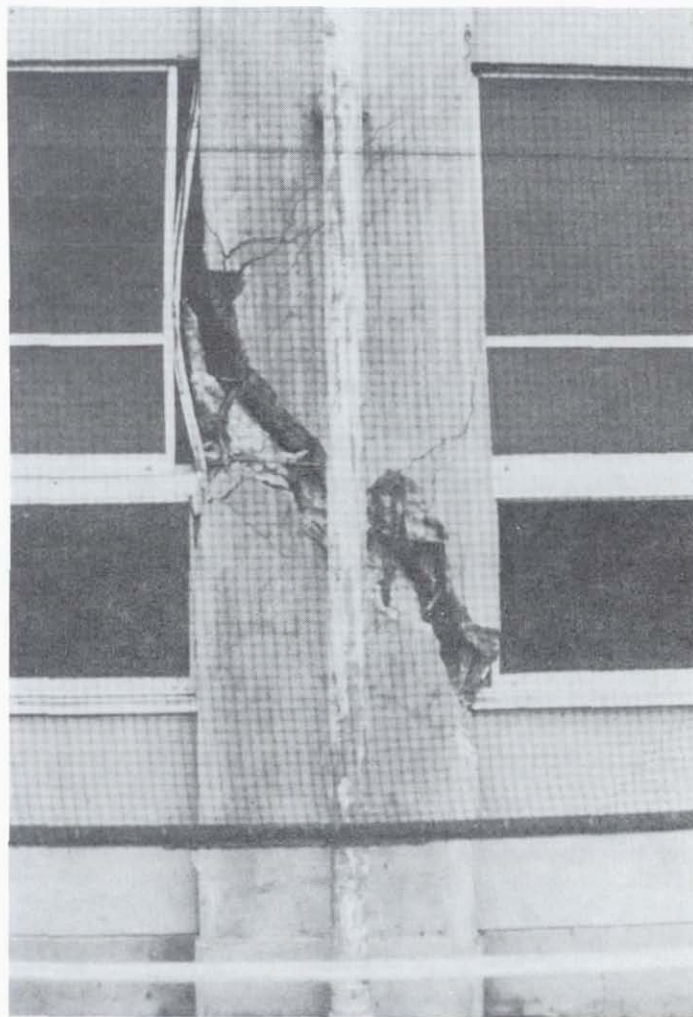

Figure 5.56 Tonan High School. Detail of column damage, exposing reinforcement.

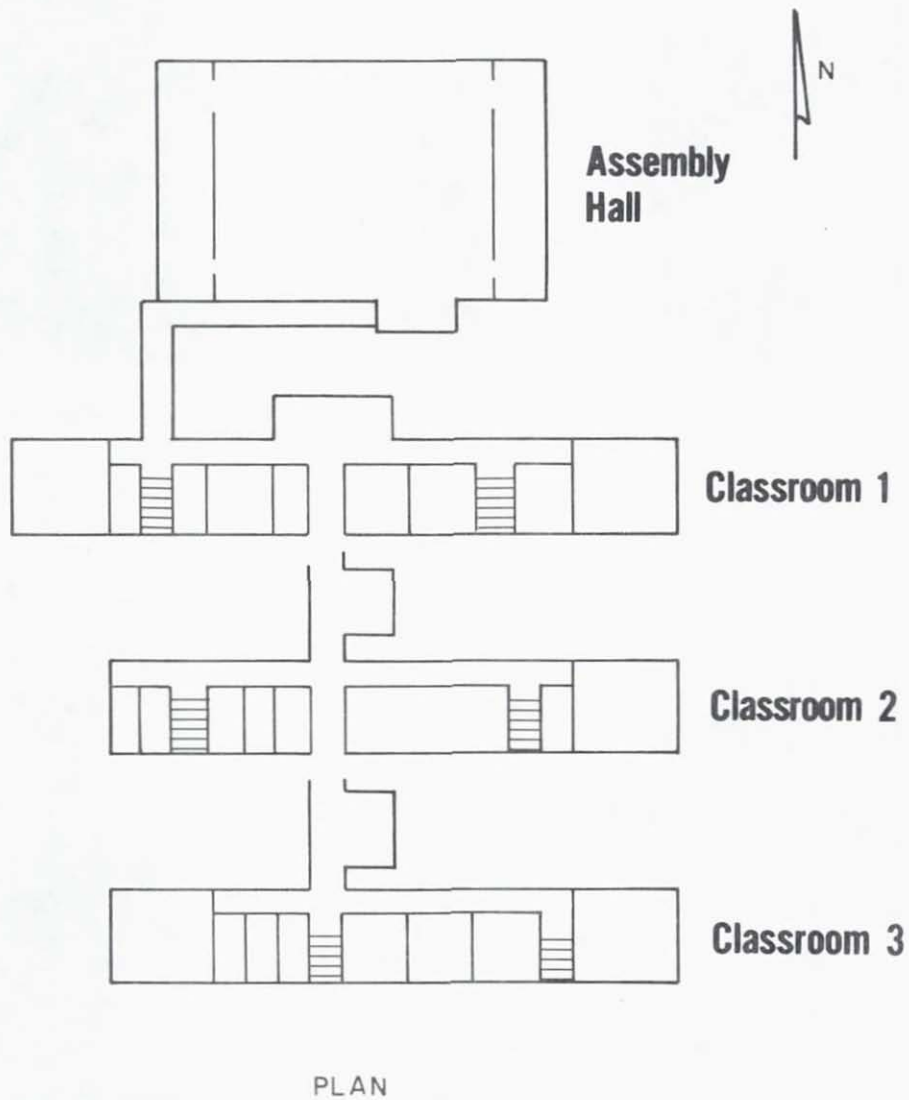

Figure 5.57 Izumi High School, Izumi City. Plan view of steel frame assembly hall and three reinforced concrete classroom buildings.



Figure 5.58 Izumi High School. Three adjacent reinforced concrete frame buildings with shearwalls suffered minor damage.

Figure 5.59 Izumi High School. Detail of panel over north entrance to building 1.



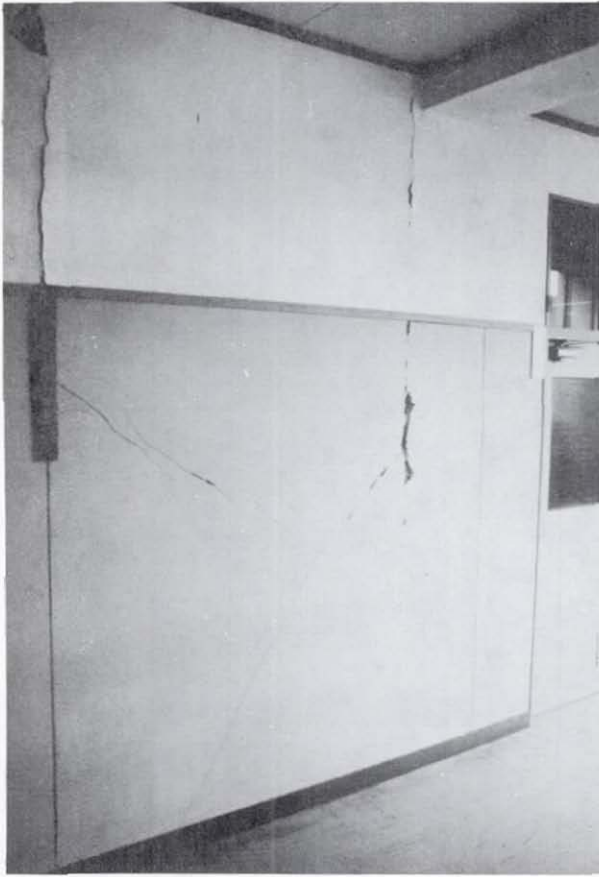

Figure 5.60 Izumi High School. An interior corridor wall in classroom building 1 aligned in the longitudinal direction of the building.

Figure 6.61 Izumi High School. The diagonal crack in the exterior wall shows that foundation settlement or uplift took place at the corner.

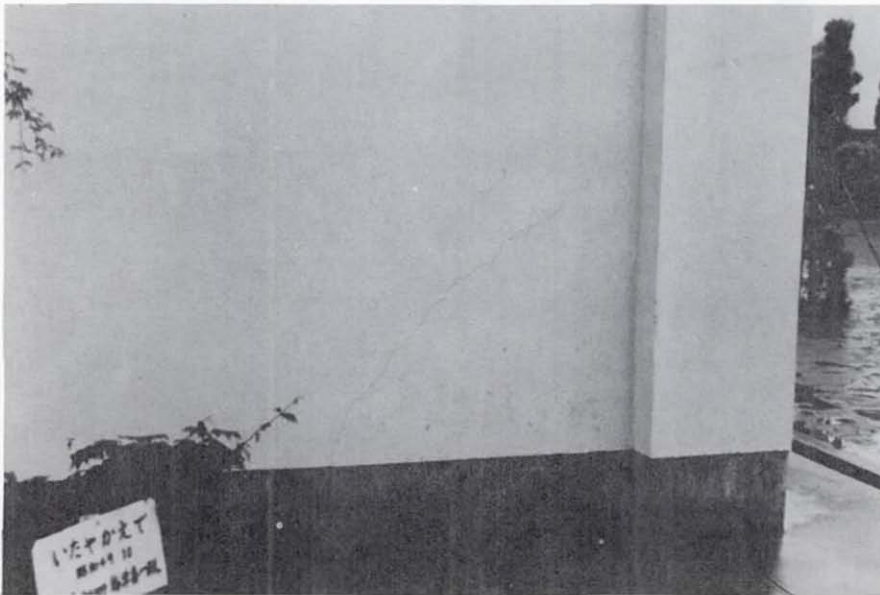



Figure 5.62 Izumi High School, typical classroom building, south face. This side of the building, which is relatively open, suffered little damage.

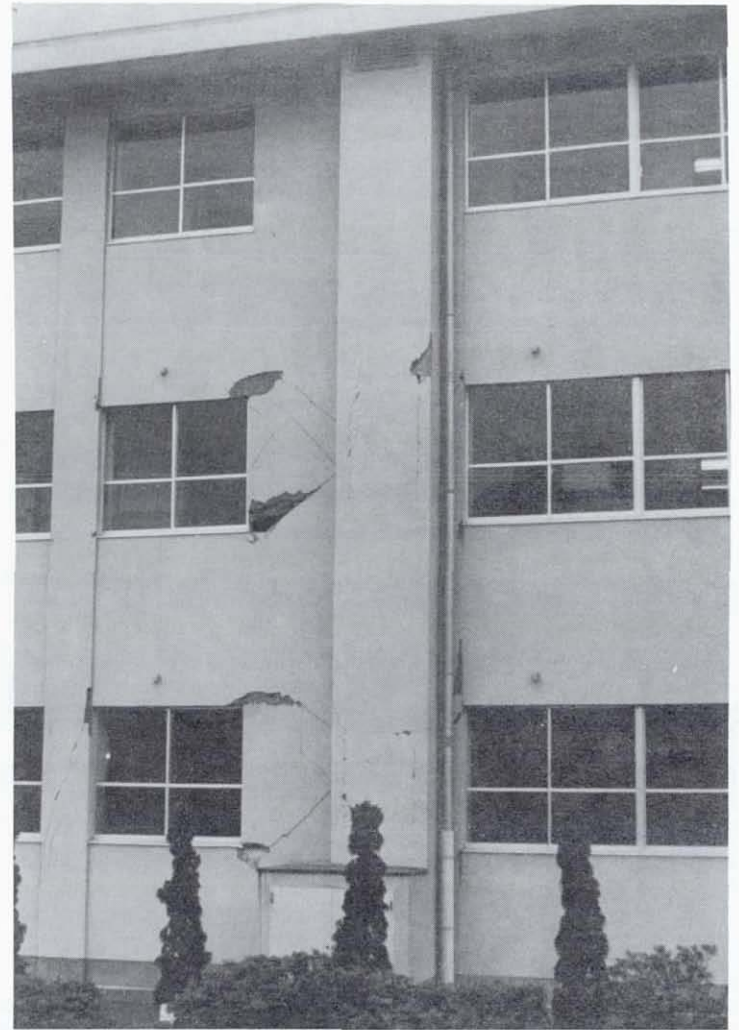

Figure 5.63 Izumi High School, typical classroom building, north face. All faces with the larger infill panels were similarly damaged.

Tohoku Institute of Technology (No. 17, Figure 5.3). The campus consists of several buildings located southwest of the downtown area of Sendai. The building layout is illustrated in Figure 5.64. The underlying soil conditions are reasonably good, being older terrace deposits. All buildings are situated on sand and have pile foundations. As may be observed from the contour map in Figure 3.12, this area of the city is quite hilly. Buildings No. 3 and 5 (labeled on Figure 5.64), constructed in 1965, were inspected in some detail. There were no strong motion instruments at the campus; however, ground accelerations at the site were estimated as 0.25g.

Figure 5.65 shows a partial view of the northeast facade on Building 5. Building 5 is situated on a steep hill running to the southwest and the northeast side entrance is actually located on the fourth-story of the eight-story reinforced concrete frame building. The upper five floors contain large classrooms and open spaces. Damage to building 5 was substantial, particularly on the northeast side. Light fixtures were shaken down and bookcases, wooden lecterns, and statues were overturned. Surprisingly, the elevator remained functional. Wall panels and floor diaphragms were cracked, (Figure 5.66). Such cracking was particularly noticeable near shear walls of the stairwell on the northeast side of Building 5.

The columns on the northeast side of building 5 were seriously damaged. Figure 5.67 and 5.68 show typical damage to exterior columns on the upper stories (stories 6 - 8). The infill panels stiffened the exterior columns on the northeast side of building 5. In contrast, the exterior columns on the southwest side and the interior columns had no such stiffening, were relatively flexible (Figure 5.69) and suffered no apparent damage. The lower story columns on the northeast side showed significant shear cracking and spalling, as illustrated in figure 5.70 for one exterior column on story four. Crack widths exceeded 10 mm in several instances. Visible column ties were spaced 250 mm apart and were wrapped around the corner longitudinal bars without hooks. Interior transverse shear walls also showed diagonal cracks. In at least one case where the transverse wall was connected to a column, the diagonal crack in the wall continued on into the column. The transverse walls were connected to the columns on the north side with the tie beams. Figure 5.71 shows one of these tie beams following the earthquake.

Adjacent to building 5 on the northwest is a three-story reinforced concrete frame building completed in 1972. Figures 5.72 and 5.73 show this building and its walkway connection to building 5. It was constructed according to the post-1971 building code. Although the building was not entered, an inspection of its exterior revealed no signs of damage.

The northeast facade of building 3 is shown in Figure 5.74. This is a four-story reinforced concrete frame building, ten spans by two. While the relatively flexible interior columns were undamaged, all of the exterior columns on the first-story cracked in shear just above the infill panels, as shown in Figure 5.75. Figure 5.76 illustrates this more clearly at one of the first-story columns on the northeast side of building 3. As can be seen, the reinforcement is undeformed. We were informed that core samples taken out of the spandrels showed no apparent damage to the concrete.

Around the entrance on the east side of building 3 and the southeast corner of its first-story, large areas of the tile facing and concrete underneath had spalled off, exposing the reinforcement (Figure 5.77). At this location, the vertical reinforcing bars were bent manually during construction in order to force them to conform to the building working drawings. The reinforcement appeared to have less than 10 mm concrete cover. The interior walls of building 3 showed extensive diagonal cracking (Figure 5.78). However the interior columns were apparently not damaged.

Figure 5.79 shows the area between walkway along the northeast side of building 5 (see also Figure 5.65). The backfill along the northeast side of building 5 has settled, causing damage to the stairs to the entrance of building 5 and adjacent retaining walls. Ground settlement also has caused the paving of the walkway to crack.

It was reported that building 3 will be demolished and building 5 will be repaired. Estimates of the costs of repair for these structures were unavailable.

Tohoku University Engineering and Architecture Building (No. 19, Figure 5.3). Tohoku University is located west of the downtown area. As may be observed from the contour map in Figure

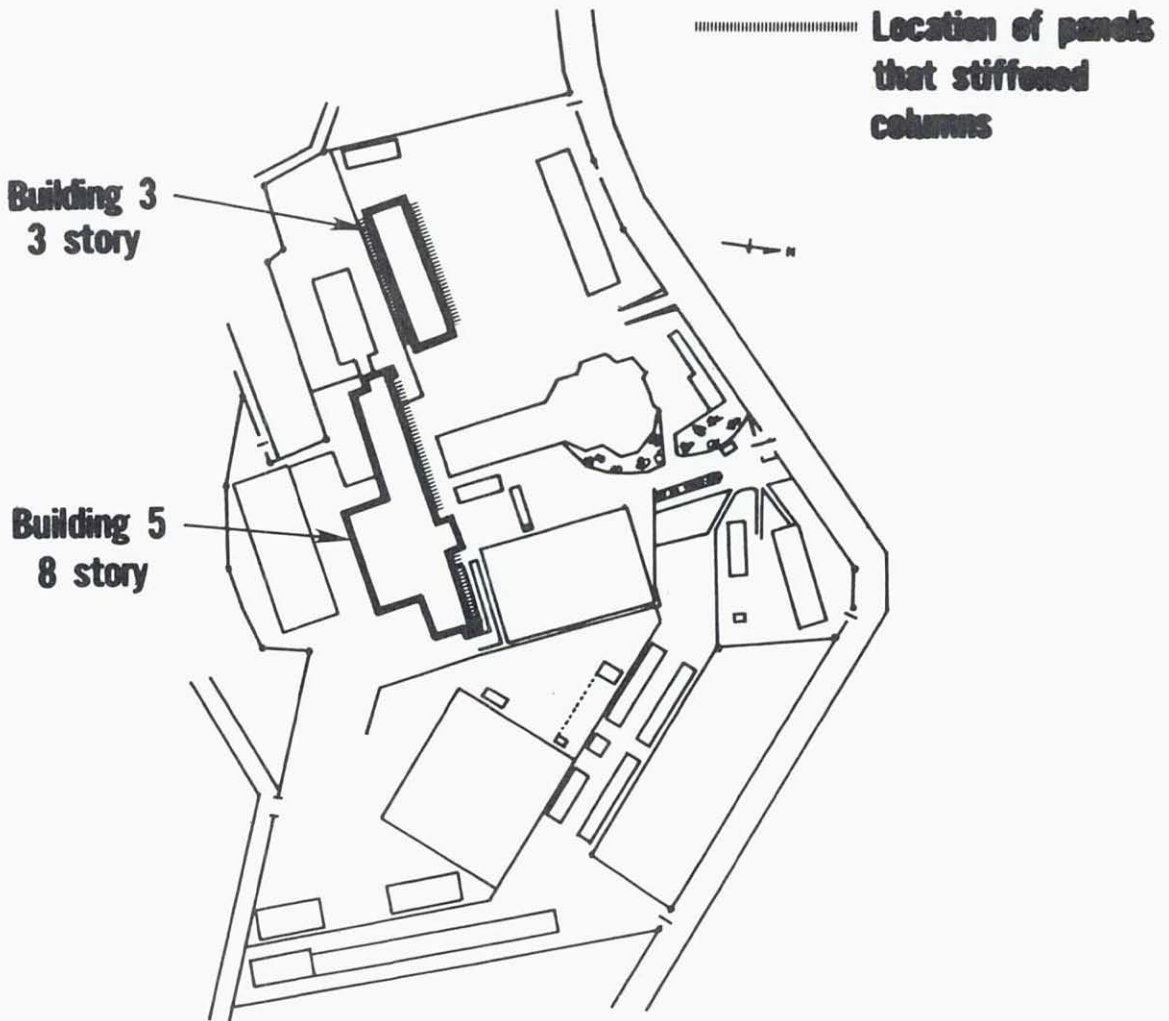

Figure 5.64 Tohoku Institute of Technology, Sendai, plan of campus. Hatching along walls of buildings 3 and 5 shows location of severely damaged columns.

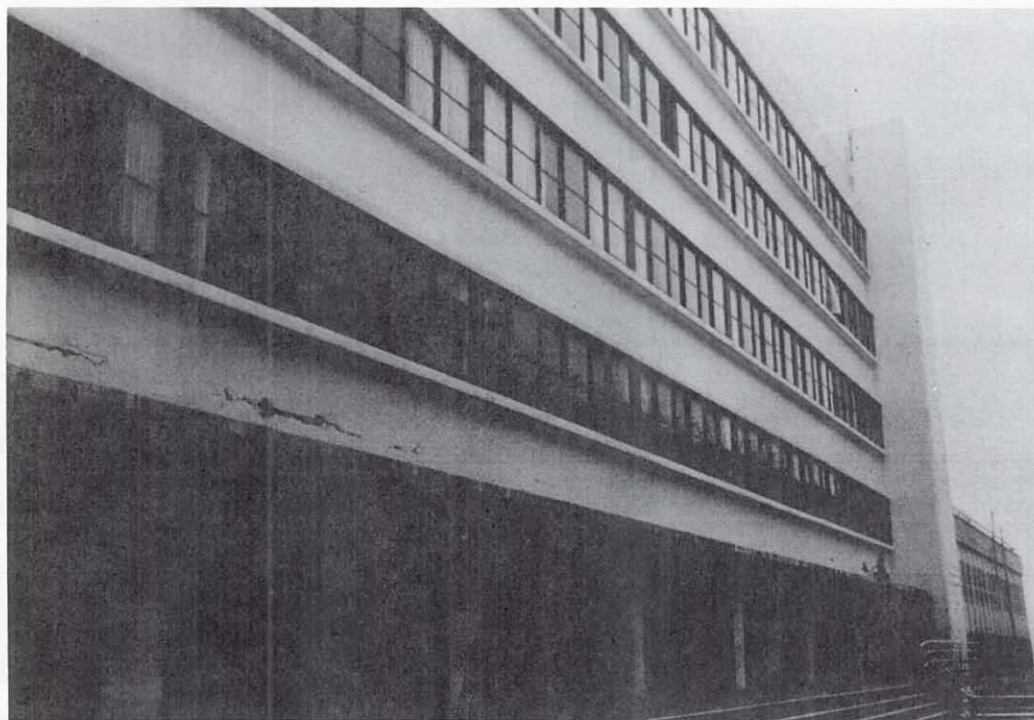

Figure 5.65 Tohoku Institute of Technology. Partial view of the entrance and north facade of building 5. Most serious damage to columns occurred on this side of the building.

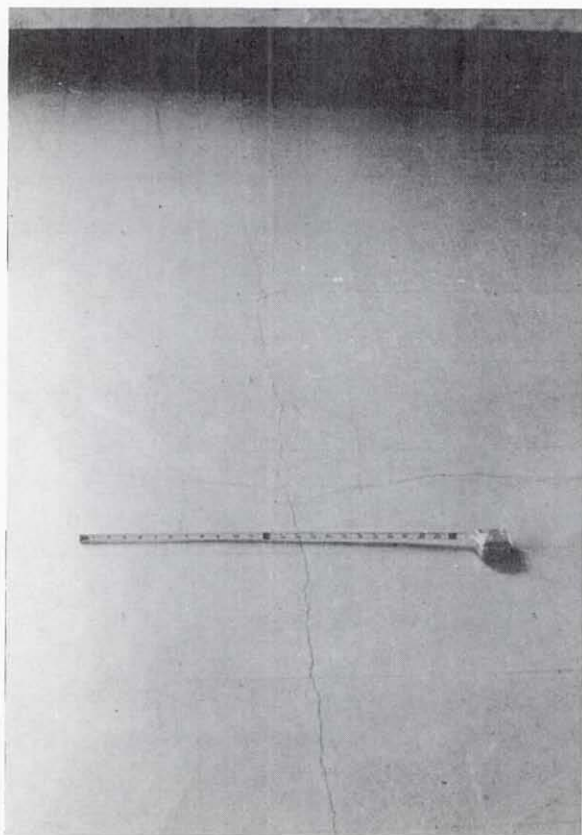

Figure 5.66 Tohoku Institute of Technology. Typical cracking of floor diaphragms at the sixth floor level, building 5.

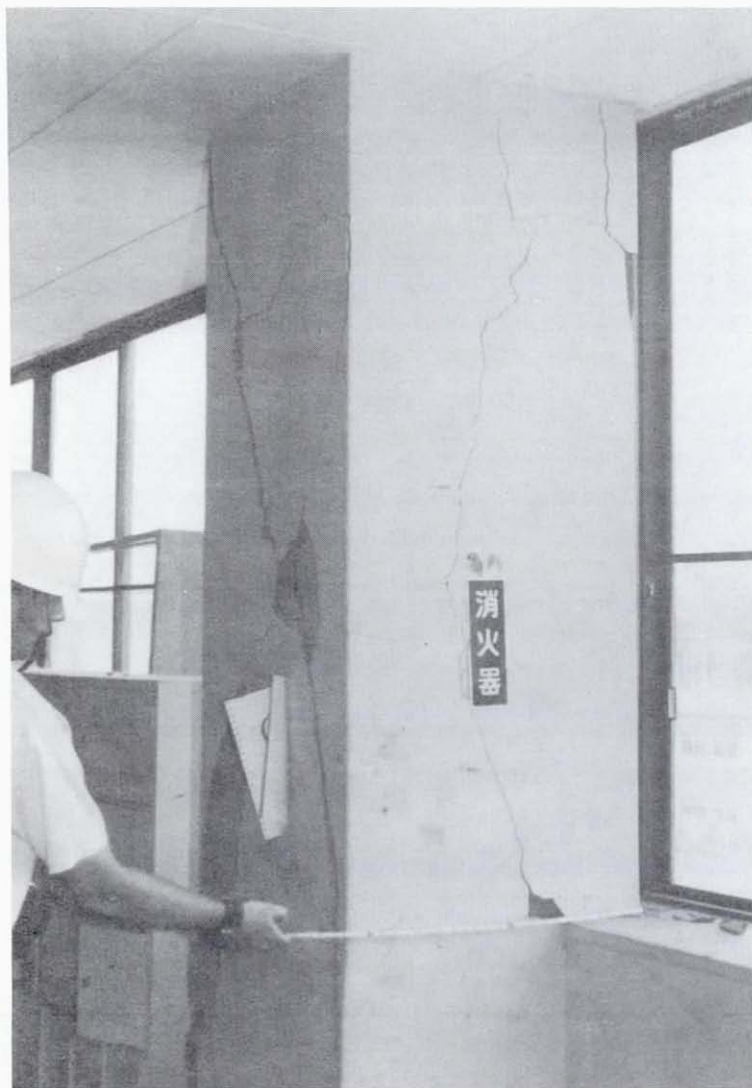

Figure 5.67 Tohoku Institute of Technology. Typical damage to seventh story column of the north facade of building 5.

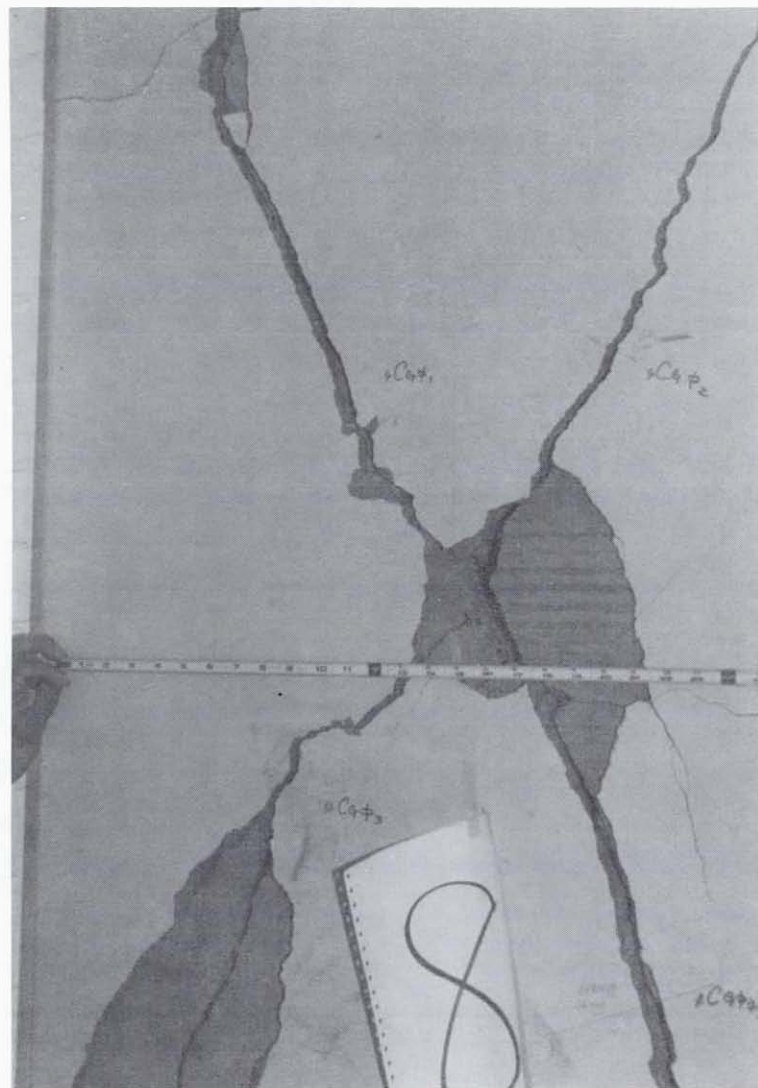

Figure 5.68 Tohoku Institute of Technology, Building 5. Detail of column damage.

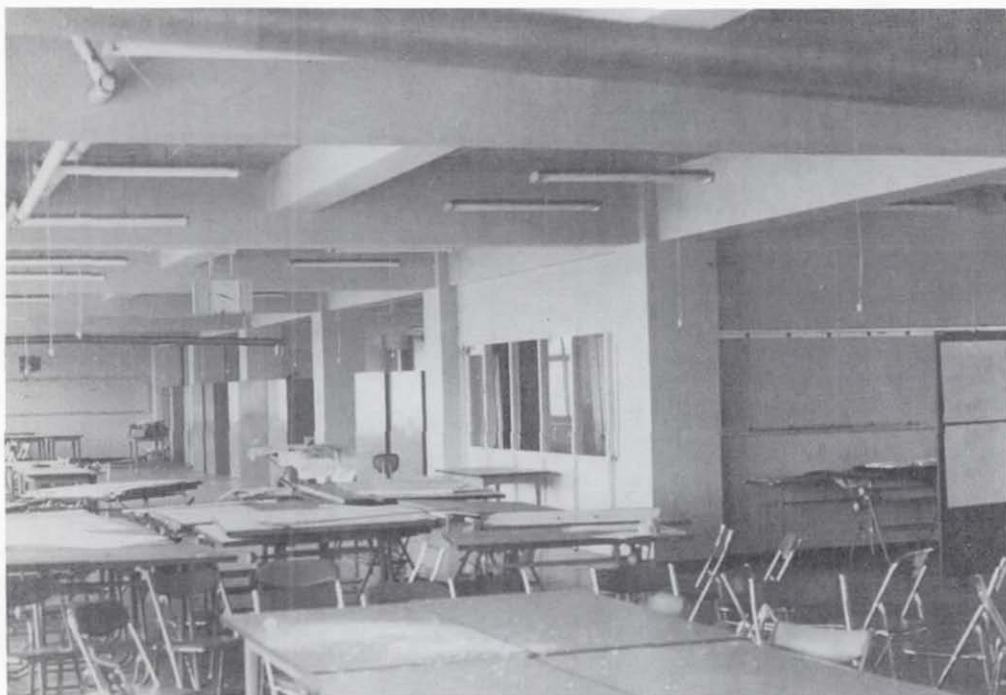

Figure 5.69 Tohoku Institute of Technology, Building 5. Seventh story interior, looking towards the lightly damaged southern exterior frame.



Figure 5.70 Tohoku Institute of Technology, Building 5. Damage to column on north side of third story. The tie spacing is 25 cm.

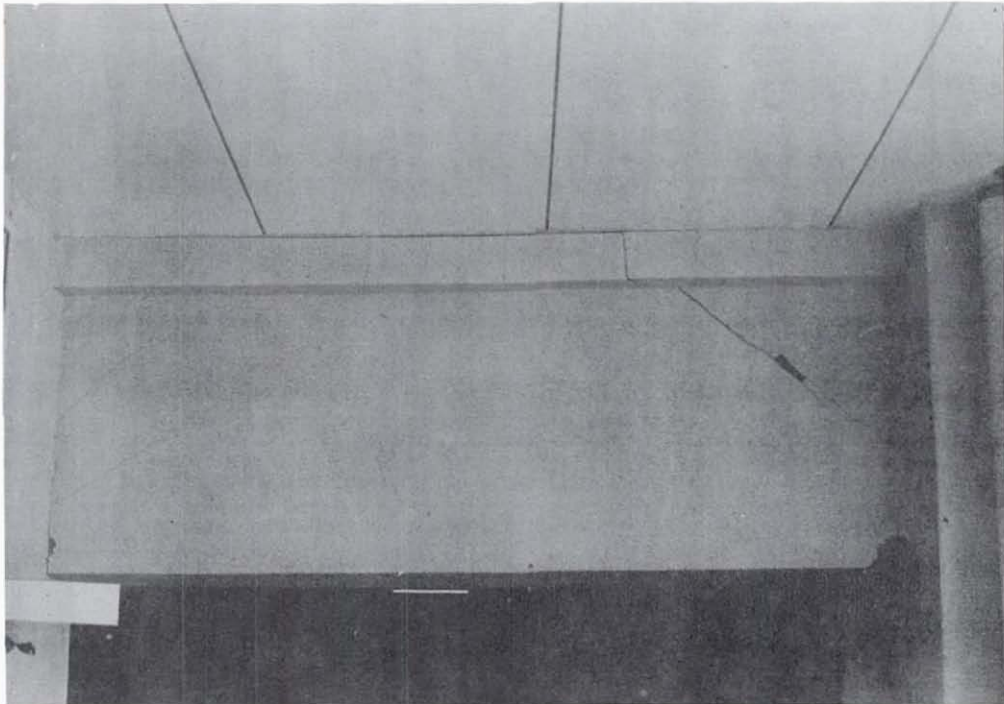
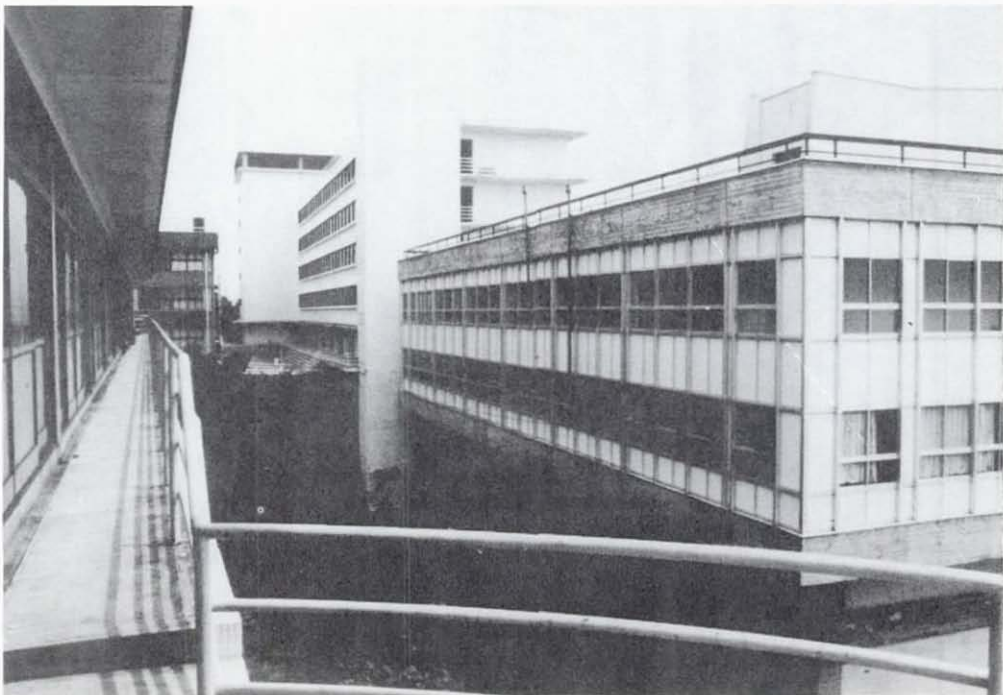

Figure 5.71 Tohoku Institute of Technology, Building 5. The tie beam over a sixth floor corridor connecting two shear walls shows diagonal cracks at both ends.

Figure 5.72 Tohoku Institute of Technology, concrete frame structure adjacent to building 5 on the west, completed in 1972.



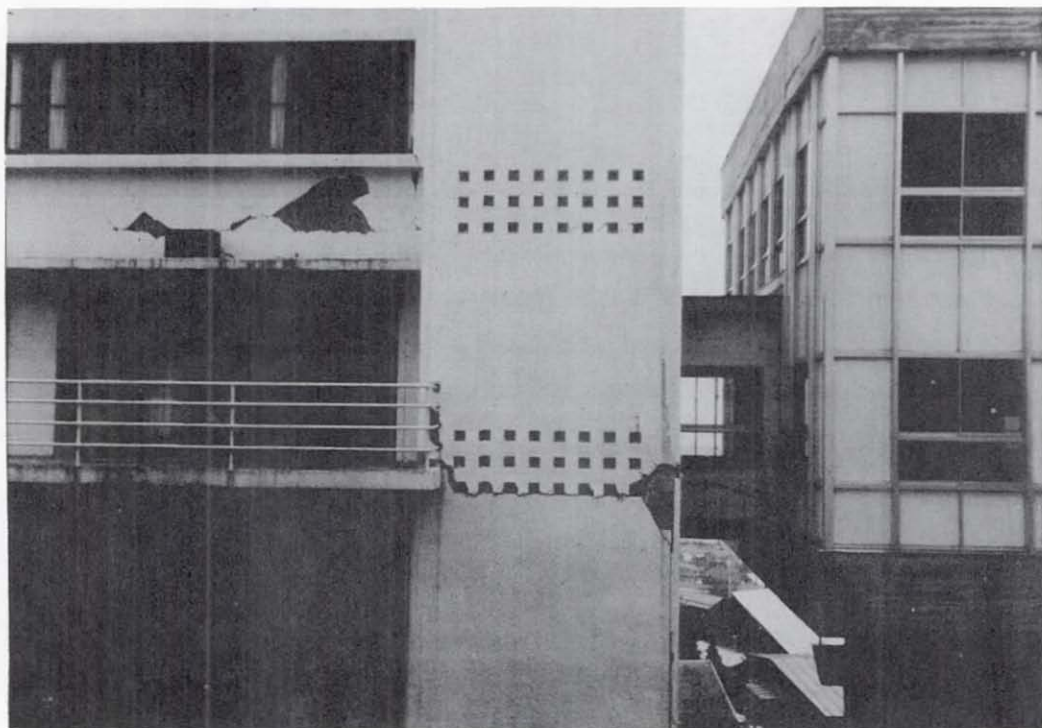

Figure 5.73 Tohoku Institute of Technology. Passage between Building 5 and the building to its west.

Figure 5.74 Tohoku Institute of Technology, Building 3. General view of the north elevation.





Figure 5.75 Tohoku Institute of Technology, Building 3. Damage to the ground floor columns on the south side of the building. Similar damage is present on the opposite side of the building.



Figure 5.76 Tohoku Institute of Technology, Building 3. Typical damage to ground story exterior column on north side of building.

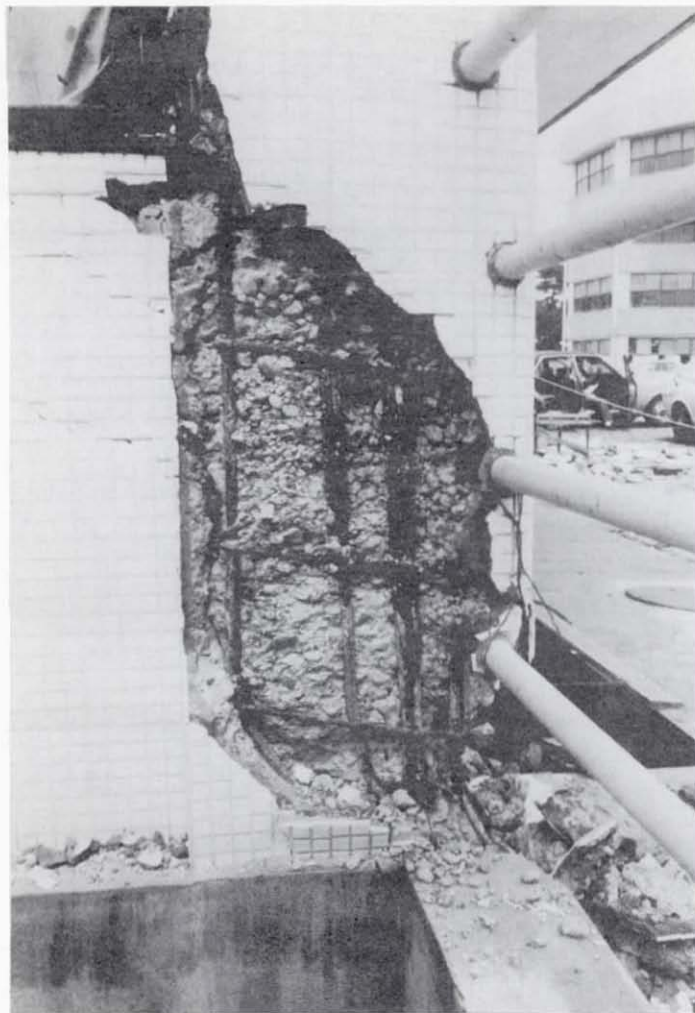

Figure 5.77 Tohoku Institute of Technology, Building 3. Detail of one of the damaged columns of the exterior frame on the south side of the building showing reinforcing details.

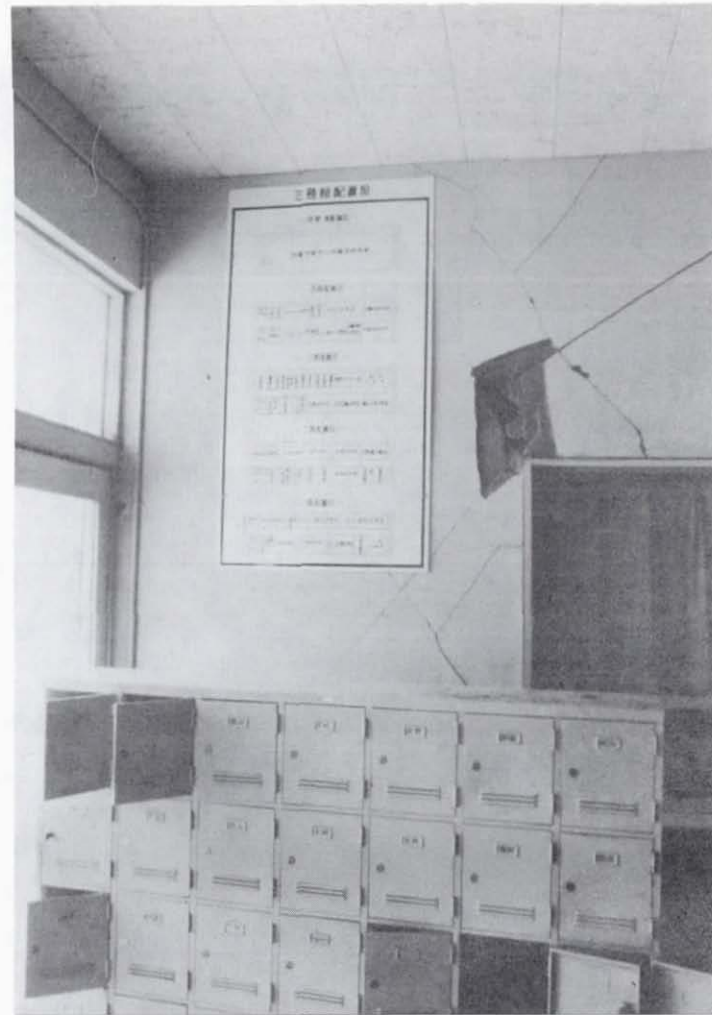

Figure 5.78 Tohoku Institute of Technology, Building 3. Interior surface of shear wall at east end of building.

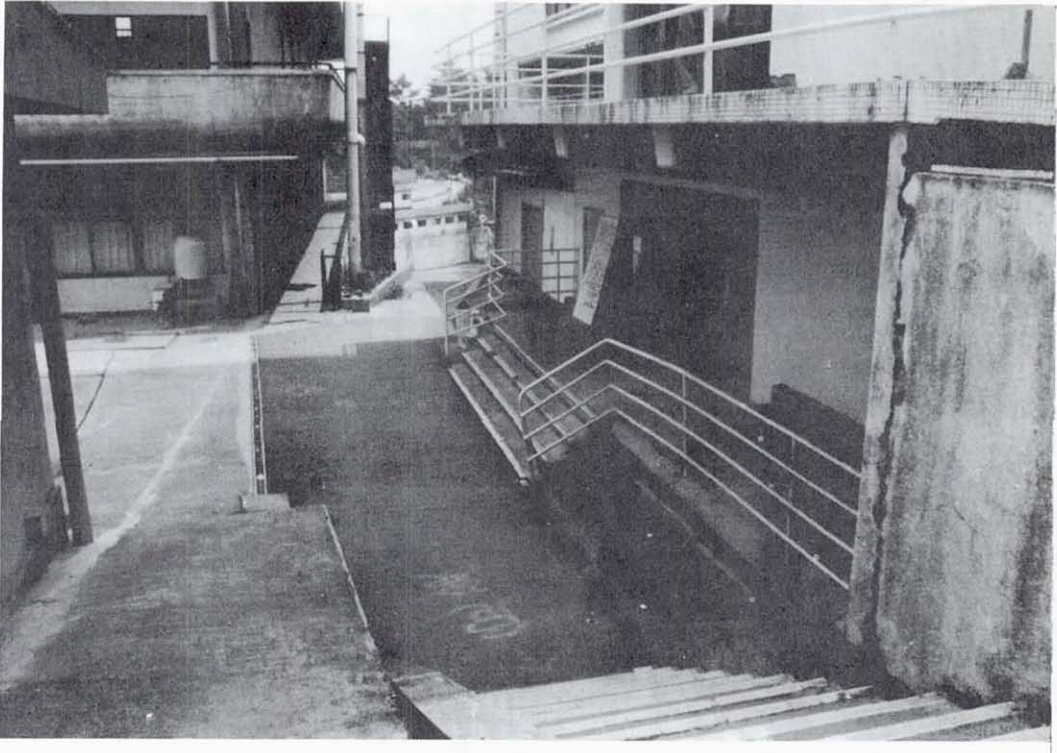

Figure 5.79 Tohoku Institute of Technology, walkway and north entrance of building 5 shows settlement of backfill along length of building.

3.12 this area of Sendai is quite hilly. The underlying stable terrace deposits provide a good foundation for buildings. The Engineering and Architecture Building on the Campus is a nine-story reinforced concrete frame structure with pile foundation approximately 10 years old. The structure was designed for a peak ground acceleration of 0.2g. A general view is shown in Figure 4.4 and plans and elevations are shown in Figure 4.5. The building is instrumented with two strong motion accelerometer instruments on the ground floor and the ninth floor. The records are discussed in detail in Chapter 4. The maximum accelerations recorded were 0.24 g at the ground floor and 1.0g on the ninth floor, both in the N-S direction.

The building performed very well in the earthquake. The February 1978 earthquake caused some cracking in shear walls and window breakage. The maximum ground floor acceleration measured then was 170 gal. After the June earthquake, the diagonal cracks had widened, but they still can be easily repaired. Figure 5.80 shows an interior transverse wall at the ground floor. The decorative glazed tile veneer has cracked and spalled along a diagonal crack in this wall. A number of windows on the upper stories were broken out and bookcases and filing cabinets were overturned. The main structural elements of the building appeared to be intact; however, minor cracks in the structural frame were reported at the lowest levels. Assuming that the first mode dominated the dynamic response, the maximum displacement amplitude at the ninth-story, computed from $A/(2\pi f)^2$ in which $A = 980 \text{ cm/sec}^2$ and $f = 1 \text{ Hz}$, was about 25 cm (10 in).

5.5 Residences

Sunny Heights Apartment Building (No. 38, Figure 5.3). This 190-unit private apartment building (Figure 5.81) is located on the east side of Sendai city on soft ground. It is a 14-story steel and reinforced concrete structure with a pile foundation, L-shaped in plan, which was built in two sections about two years ago. The L-shaped plan is not conducive to earthquake resistance because torsional effects may be amplified. The earthquake caused numerous diagonal cracks throughout the height of the building, particularly around doorways and window openings, as shown on the east face of the building in Figure 5.82. The extensive cracking in the nonstructural panels adjacent to doorways created major problems for occupants attempting to open doors and windows in the first ten stories. The most severely damaged panels were oriented in the N-S direction. Despite the extensive damage to nonstructural elements, the main loadbearing structural members appeared to be undamaged by the earthquake.

There was extensive evidence of ground cracking and settlement adjacent to the foundation and the walkway surrounding the building, as can be seen in Figure 5.83, where the support post below the bottom rail of the fence is exposed. The ground adjacent to the foundation subsided several inches in some cases. Portions of the parking area around the building appeared to have settled about 18 in (460 mm). There was a large water shortage tank located on top of the roof. It was shaken loose from its anchorage when the anchor bolts failed and the horizontal movement also caused the supply pipe to be damaged.

Single Family Dwellings. Major causes of the destruction to dwellings were landslides and rockfalls, inadequate foundations, and construction which lacked lateral bracing. Many homes in the Sendai vicinity have heavy tile roofs, and literally thousands of buildings had damaged roofs of varying degrees. Falling tile resulted in some injuries.

A major cause of deaths and injuries was collapsing or falling walls made of stone or concrete cinderblock. These walls serve as fences, for privacy, and as noise barriers. The Japan Building Code requires that walls over 1.5 m in height be reinforced in both directions. Although some of the walls that failed contained reinforcing, in most cases they contained less reinforcing than called for by the modern code. More fatalities resulted from falling walls containing inadequate reinforcing than from walls with none. Those with no reinforcing tended to crumble while those with reinforcing toppled as units on people who were nearby or who held onto them for stability when the earthquake occurred. In some cases, the masonry block cores were grouted but the reinforcing steel had been omitted.

Figure 5.84 shows an example of the ground cracking resulting from subsidence in one of the hilly areas in Sendai. The loss of foundation support has caused extensive cracking in the building walls. In Figure 5.85, the front steps and breezeway have separated some 30 cm

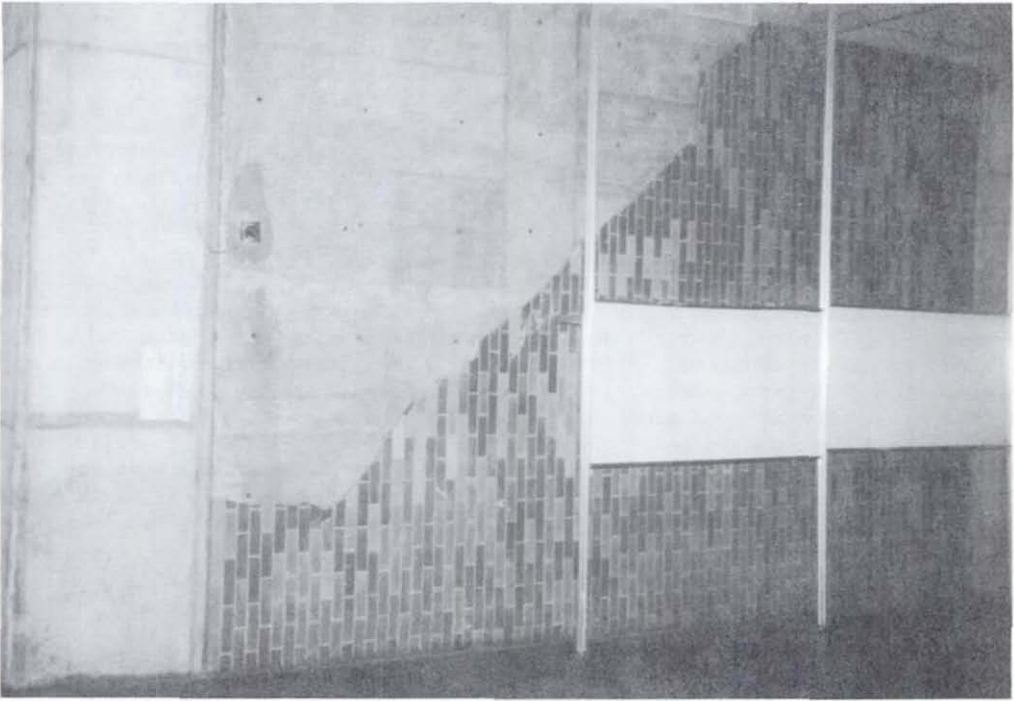

Figure 5.80 Tohoku University Engineering Building. Damage to glazed tile veneer of shear wall at ground level.

Figure 5.81 Sunny Heights Apartment Building, Sendai. General view from the southwest.

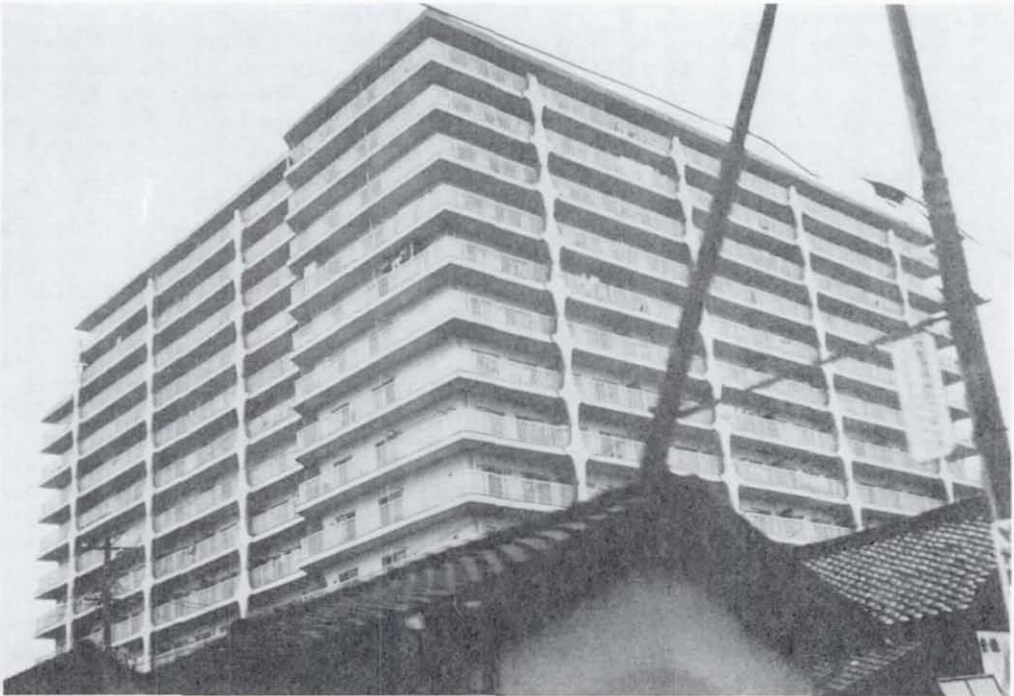



Figure 5.82 Sunny Heights Apartment Building. Detail of cracking of panels adjacent to doorways. Such cracking was typical at all levels on the east facade of the structure.

Figure 5.83 Sunny Heights Apartment Building. Ground cracking and settlement adjacent to walkway surrounding the building.





Figure 5.84 Sendai. Damage to single family residence due to loss of foundation support. (Japan National Land Agency photograph)



Figure 5.85 Sendai. Damage to single family residence due to ground settlement. (Japan National Land Agency photograph)

from the remainder of the structure due to ground settlement. There were many instances where tile roofs were badly damaged even when the structure remained standing (Figure 5.86).

Two examples of collapsed masonry-unit walls are shown in Figures 5.87 and 5.88. The wall shown in Figure 5.87 was not reinforced, and crumbled during the earthquake. The wall in Figure 5.88 contained reinforcement but was not anchored adequately to its foundation and toppled over practically as a unit.

Many single family dwellings were undamaged by the earthquake and, perhaps surprisingly, undamaged homes were found adjacent to larger engineered buildings that had been damaged. In a residential neighborhood at the bottom of the slope south of building 5 at Tohoku Institute of Technology, there was no visible damage to walls or tile roofs in any of the houses. Similarly, only minor damage could be observed to homes at the bottom of the bluff next to Tonan High School.

5.6 Summary

Considered collectively, severe damaged or collapsed reinforced concrete buildings shared a number of common features. Probably most significant, they were all designed prior to the 1971 revisions to the building code, at which time detailing requirements became more stringent. These older structures probably had little ductility and energy-absorbing capacity due to the use of undeformed bars and widely spaced column ties, insufficient ties and anchorage of reinforcement at beam-column joints, failure to provide hooks on ties, etc. None of the columns in failed buildings appeared to be spirally reinforced, which would be more ductile in their behavior. Damaged buildings frequently had flexible first stories and rigid upper stories. Building layouts were irregular and caused structural discontinuities. Partial infilled spandrel walls between columns contributed to many column failures. In some cases, the fate of an entire building rested on the integrity of a single column or wall. Mechanisms for load transfer following local failure through good floor plans, longitudinal spline walls and returns on shear walls would reduce the occurrence of complete collapse following failure of a single element. Stiffer structures with shear walls tended to have less damage than more flexible buildings.

It should be borne in mind that many of the buildings investigated have been through two recent major earthquakes (February 20 and June 12, 1978) without suffering damage. The total damage due to the June 12th earthquake constitutes a small percentage of the total capital investment in buildings and structures, despite recorded ground accelerations of as high as 0.25g to 0.30g.

5.7 References

- 5.1 Okamoto, S., Introduction to Earthquake Engineering, John Wiley, 1973 (Chapter 8, esp).
- 5.2 Standards for Aseismic Civil Engineering Construction in Japan, Ministry of Construction Standard No. 1074.
- 5.3 Watabe, M., "Summary of Present Codes and Standards in the World," 1978.
- 5.4 "Design Essentials in Earthquake Resistant Buildings," published by the Architectural Institute of Japan, Elsevier Publishing Co., London, 1970.
- 5.5 Uniform Building Code, 1976 Edition, International Conference of Building Officials, Whittier, CA. 1976.
- 5.6 "Tentative Provisions for the Development of Seismic Regulations for Buildings," Nat. Bur. of Stand. Special Publication SP510 (ATC 3-06), Washington, D.C., June 1978.
- 5.7 "Building Code Requirements for Reinforced Concrete," (ACI 318-77), American Concrete Institute, Detroit, MI, 1977.



Figure 5.86 Typical damage to tile roofs in Sendai (Japan National Land Agency photograph)

Figure 5.87 Failure of unreinforced concrete masonry wall in Sendai (Japan National Land Agency photograph)



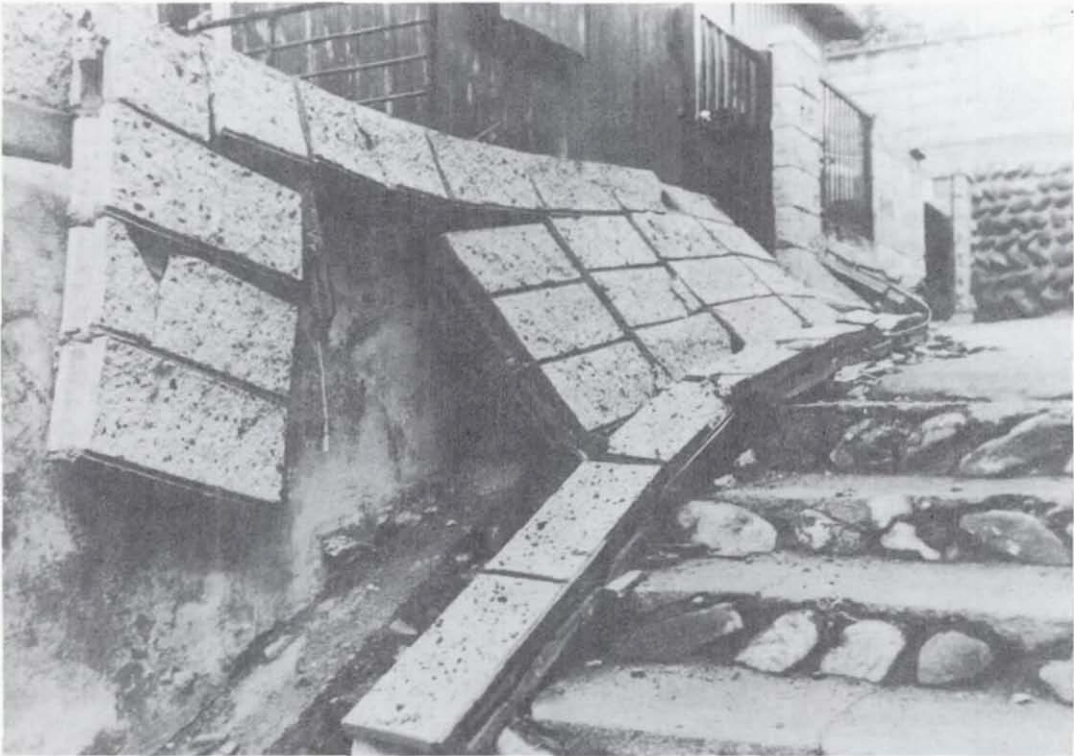

Figure 5.88 Failure of a reinforced concrete masonry privacy wall in Sendai.
(Japan National Land Agency photograph)

6. EFFECTS ON INDUSTRIAL FACILITIES AND LIFELINES*

6.1 Introduction

As discussed in Chapter 2, the preliminary Japanese estimates of damage at the end of June, 1978 amounted to approximately \$830 million. Of this total \$455 million was to factories, stores and other business establishments. This represents about 55 percent of the total damage. Damage to transportation, electrical, gas, and other lifeline facilities also represents a substantial proportion of the remaining damage. Of course, these figures do not include secondary types of damage, such as lost production for factories, lost revenue for power and gas utilities, etc. Thus, losses to industry and other business establishments dominate the damage statistics from the Miyagi-ken-oki earthquake of June 12, 1978. In this respect, the earthquake is very different from the majority of damaging earthquakes that have been reported in the literature.

Most of the significant structures in the Sendai area are modern structures, designed under advanced earthquake engineering concepts. The construction and inspection practices also appear to be of generally excellent quality. However, most of the capital investment in industrial facilities is concentrated in equipment systems, which typically are not protected against earthquakes to the same degree as the buildings which house them. This lower level of seismic resistance may explain why a high proportion of the total damage was caused to factories, stores and other business establishments.

A small number of industrial facilities and lifeline structures were briefly inspected. Damage varied from negligible, at the Fukushima Nuclear Power Plant, to severe, at the Sendai Gas Facility. Sendai is a large industrial city, with more than 6,500 business/manufacturing firms. The investigated sample of facilities represents a small fraction of the damage caused by the earthquake and of the facilities that were affected.

At the time of the reconnaissance, Japanese engineers were already conducting investigations of some of the facilities mentioned herein, and detailed reports will be available in the future. This is particularly true of the power facilities in and near Sendai. Let us hope that much of this important information will be translated into English.

This section of the report contains observations that were collected and recorded in a very brief time, and undoubtedly contains some data errors. In addition, no attempt is made here to analyze the structures and equipment or their performance. The primary objective of this report, and of the reconnaissance investigation, is to observe the performance of earthquake-resistant and other buildings, structures, and equipment.

The maps of Figures 1.1, 5.3 and 6.1 show the sites and facilities treated in this section of the report.

6.2 Fukushima Nuclear Power Plant Complex

The Fukushima Nuclear Power Plant Complex is owned and operated by the Tokyo Electric Power Company. It is located on the Pacific coast of Fukushima Prefecture, about 7 km south of the town of Namie, and is southeast of the town of Fukushima. The site is approximately 140 km from the epicenter of the earthquake. According to Chapter 3, faulting may have extended as much as 60 km west of the epicenter. In that case, the plant site may be located about 80 km (50 mi) from the nearest location of the source of energy, as shown in Figure 1.1

The complex has six nuclear units, as shown in Figure 6.2, for a total of approximately 4,700 MW, and is the largest nuclear power complex in the world. The site is heavily instrumented with strong motion accelerometers. Numerous records were made; the peak ground acceleration was 0.125 g and the duration of strong motion was in excess of 30 seconds. Because most U.S. nuclear power plants are designed to criteria that is similar to the seismic motion to which the Fukushima site was exposed, this earthquake represents a unique event. This is the first

* Prepared by Peter I. Yanev, URS/John A. Blume and Associates, San Francisco, California.

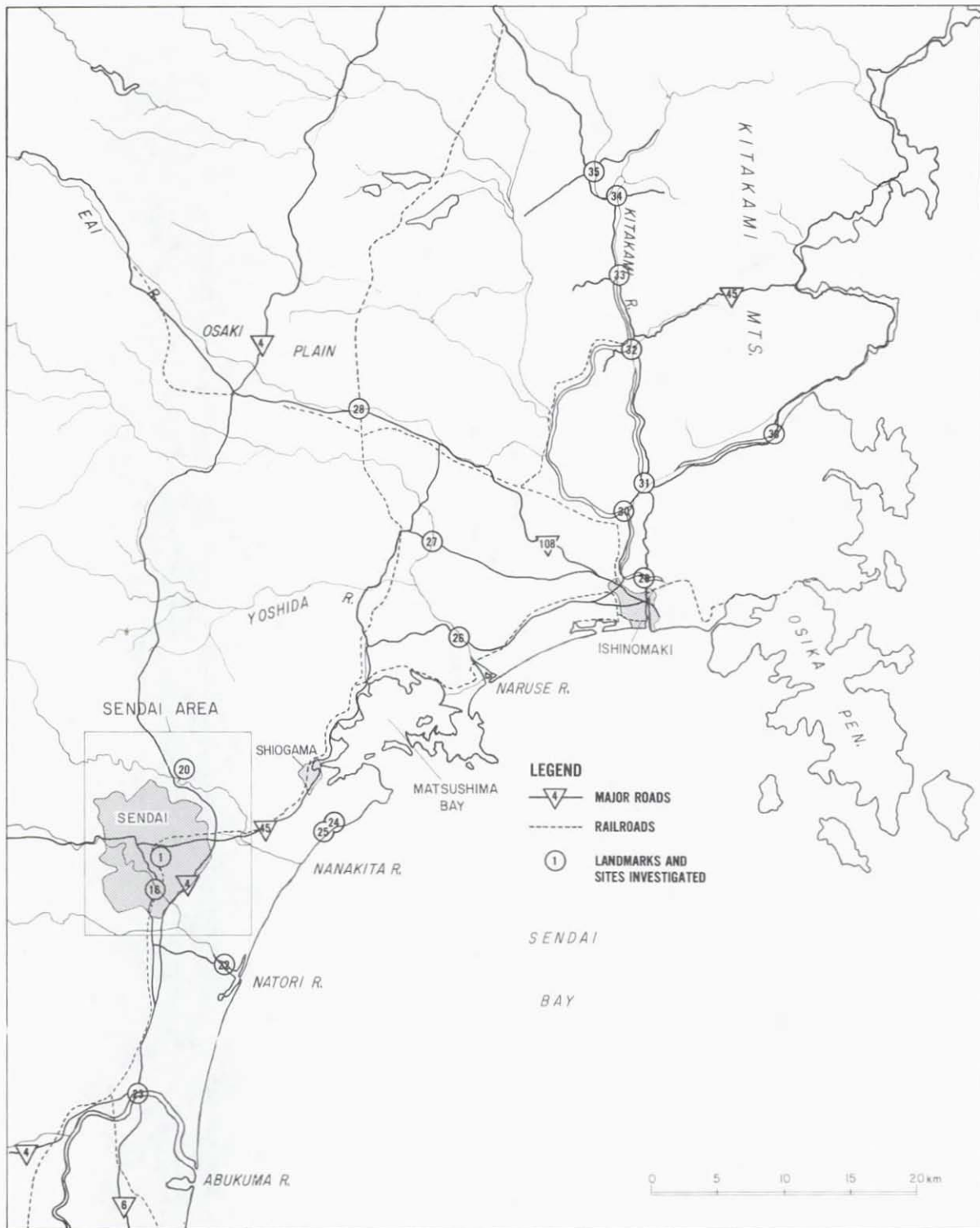

Figure 6.1 Map of Miyagi Prefecture, showing major landmarks and sites of damage visited. (see Table 5.1 for identification).



Figure 6.2 Fukushima Nuclear Power Plant: a general view showing the six units. They are, from right to left, Unit 6, Unit 5, Unit 1, Unit 2, Unit 3, and Unit 4. (Tokyo Electric Co. photograph)

time that a modern nuclear power plant was exposed to strong ground motion with long duration. In addition, the presence of six units at one site represents a good statistical sample.

Table 6.1 summarizes some of the pertinent data for this six-unit complex:

At the time of the UJNR team visit, June 23, 1978, 11 days after the earthquake, Units 1, 2, 3 and 5 were operating; Unit 6 was still under construction, but was essentially completed, and it is believed that Unit 4 was scheduled to go into commercial operation soon. The above table indicates that the expected date of commercial operation for the unit was sometime in October of 1978.

Units 1 through 5 have a Mark 1 (light-bulb-torus) type of containment structure; Unit 6 has a Mark 2 (over/under) type of containment (see Figures 6.3 and 6.4). USR/Blume Engineers formulated the seismic design criteria for the plant and performed the original seismic analyses for the General Electric Company and the Tokyo Electric Power Company.

The plants are founded on a competent soft mudstone formation with a thickness in excess of 300 m. Extensive cuts were necessary to level the site and to reach the mudstone, which has a shear wave velocity of about 600 m/sec.

Unit 1 was designed for a peak ground acceleration of 0.18g and a response spectrum based on the Taft record from the Southern California (Kern County) earthquake of 1952.

The reconnaissance team inspected the exterior of Unit 1 and the exterior and interior of Unit 6, including the containment structure, the reactor vessel pedestal, some of the equipment on the refueling floor, some of the equipment in the reactor building, the underside of the control rod drive in the containment, miscellaneous critical and non-critical piping, various critical and non-critical cable trays, the reactor building, the turbine building, the turbine overhead crane, and various auxiliary structures, equipment and tanks (see Figures 6.5 through 6.9). There was no damage or evidence of working of connections in any of the inspected areas. The only reported damage to the complex was to some non-critical electrical insulators, shown in Figure 6.10, some distance to the west of Units 1 and 2 (see the following discussion on the effects to electrical insulators at the Sendai Substation in Izumi, near the city of Sendai).

Units 1 and 6 are instrumented with between 20 and 30 strong motion accelerometers and much valuable information was obtained from the earthquake. The peak ground acceleration, which could be considered to be a "free-field" acceleration (see Figure 6.11) is 0.125g. (EW direction). The corresponding accelerations in the NS direction and Up/Down directions are 0.100g and 0.050g. The strong motion exceeds 30 sec in duration. The reported maximum response acceleration in the buildings is reported to be about 0.5g. Higher accelerations would be expected in instrumented equipment or piping systems. It is interesting that records were obtained from instruments located on the base slabs of the two units and at downhole instruments, about 30 to 40 m below two of the containments. Thus, it may be possible to conduct a detailed soil-structure interaction study for the plant.

Tokyo Electric Power Company is also conducting model studies of the plant at the site. A 1/15th scale model of the containment has been constructed a few hundred yards away from the nuclear units. The model, shown in Figure 6.12, was also instrumented, including another downhole instrument, and additional records are available from the study. At the time of the investigation the company was beginning to evaluate the recorded data.

6.3 New Sendai Power Plant, Tohoku Electric Power Company

The New Sendai Power Plant, owned and operated by the Tohoku Electric Power Company, is located on the Pacific shore, 15 km east of the center of Sendai. The site is adjacent to the Sendai refinery of the Tohoku Oil Company which suffered extensive damage from the earthquake (as discussed elsewhere in this chapter). The plant shown in Figure 6.13, has two Mitsubishi oil-fired boilers. Unit 1 was completed in 1971 and has a capacity of 350 MW; the 600-MW Unit 2 was completed in 1973 and is the largest unit of the company. The total capacity of the Tohoku Electric Power Company is 5,715 MW, this plant representing about 17 percent of that capacity.

Table 6.1

	Net MWe	Type	Reactor Supplier	Generator Supplier	Architect Engineer	Constructor	Con- struc- tion stage (%)	Commercial Operation	
								Orig. sched- ule	actual or ex- pected
Fukushima One 1 (Fukushima)	460	BWR*	GE/Toshiba	GE/Hitachi	Ebasco	Kajima	100		3/71
Fukushima One 2 (Fukushima)	784	BWR	GE	GE/Toshiba	Ebasco	Kajima	100		7/74
Fukushima One 3 (Fukushima)	784	BWR	Toshiba	Toshiba	Toshiba	Kajima	100		3/76
Fukushima One 4 (Fukushima)	784	BWR	Hitachi	Hitachi	Hitachi	Kajima	92	6/76	10/78
Fukushima One 5 (Fukushima)	784	BWR	Toshiba	Toshiba	Toshiba	Kajima	96	12/75	4/78
Fukushima One 6 (Fukushima)	1100	BWR	GE	GE/Toshiba	Ebasco	Kijima	78	10/76	10/79

* BWR - Boiling Water Reactor

(Source: Nuclear News Buyers Guide, mid-February 1978)

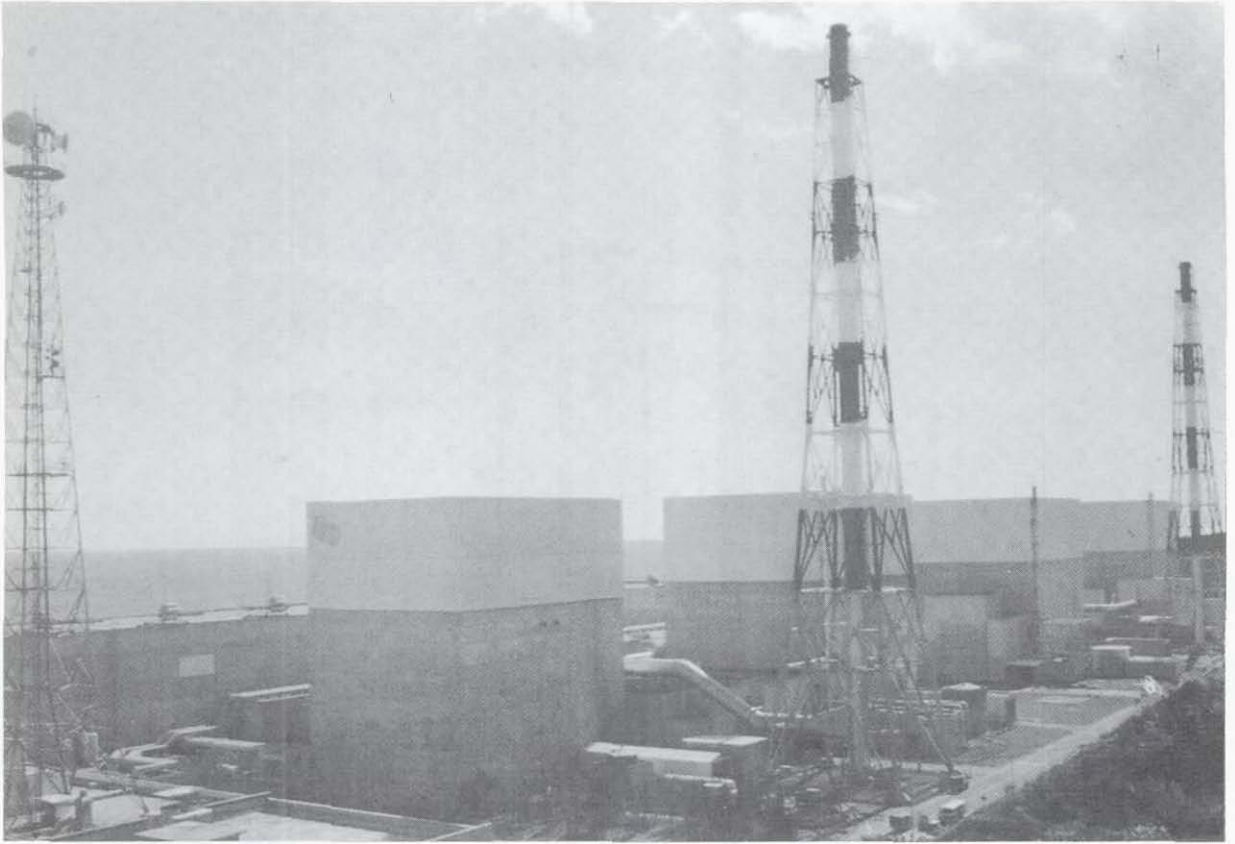

Figure 6.3 Fukushima Nuclear Power Plant: the containment structures of Units 1 through 4. None of these structures showed damage. (Tokyo Electric Co. photograph)

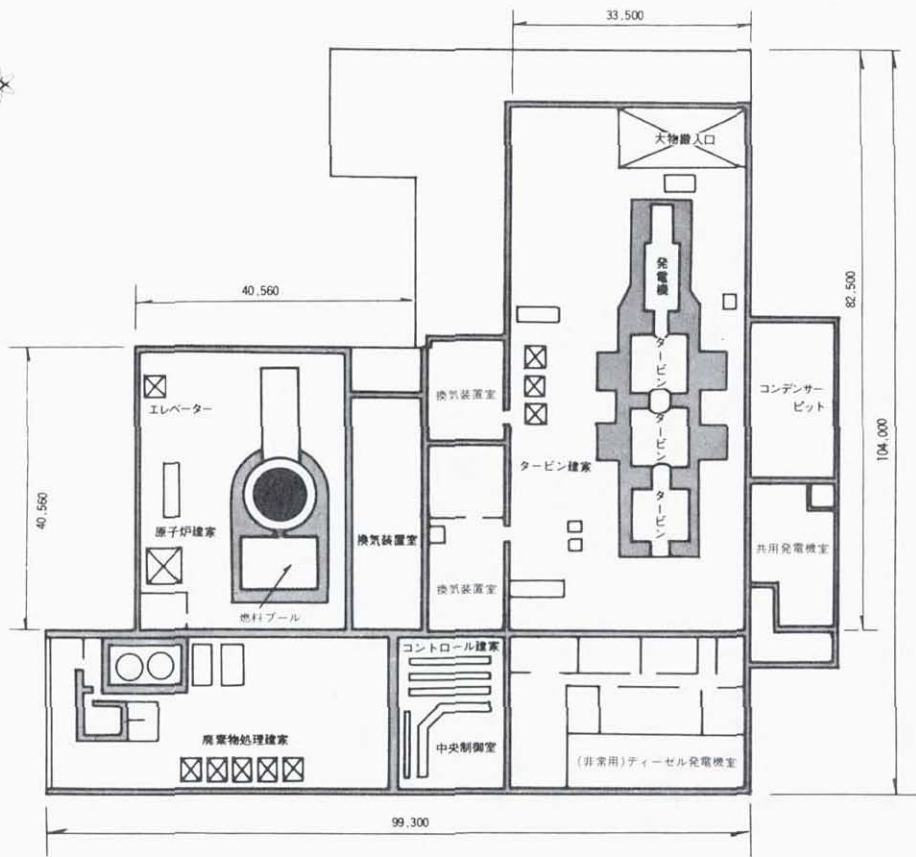

Figure 6.4 Fukushima Nuclear Power Plant: Typical elevation view through the reactor/containment building and the turbine building and a plan view across the refueling floor of the reactor building and the operating floor of the turbine building.

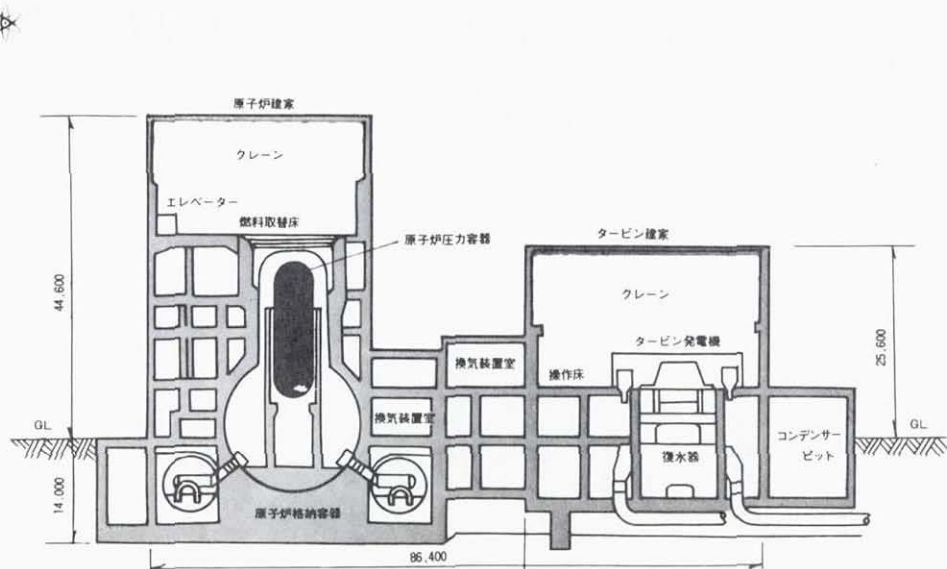



Figure 6.5 Fukushima Nuclear Power Plant: large, undamaged safety related water storage tanks that are located between units 1 and 5.

Figure 6.6 Fukushima Nuclear Power Plant: a view of the braced steel frame roof and the overhead crane of the turbine building of Unit 6.



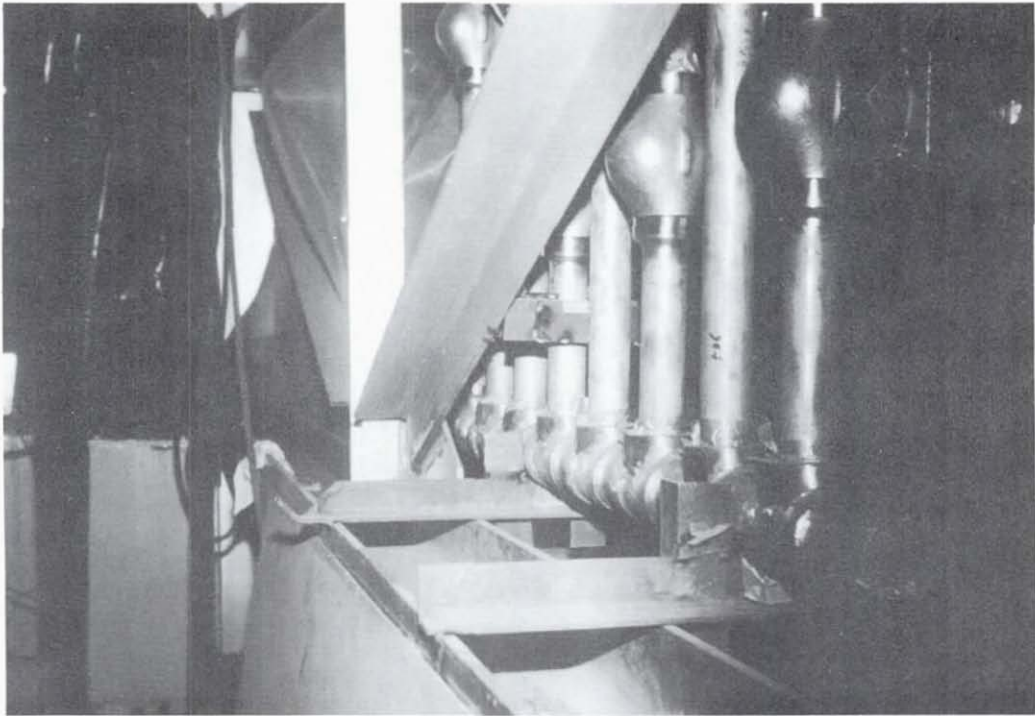

Figure 6.7 Fukushima Nuclear Power Plant: a partial view of the Unit 6 control rod drive and its supports. The unit is still under construction and was more than 95% completed at the time of the reconnaissance. There was no apparent damage or any evidence of working connections at this system or at the other systems of Unit 6 that were examined.

Figure 6.8 Fukushima Nuclear Power Plant: a typical view of massive seismic and/or pipe whip bracing of critical piping inside the reactor building of Unit 6. The equipment showed no evidence of damage. This unit is still under construction.





Figure 6.9 Fukushima Nuclear Power Plant: a partial view of the control room of Unit 5. At the time of the visit on June 23, 1978, 11 days after the earthquake, this unit was operating.

Figure 6.10 Fukushima Nuclear Power Plant. Broken ceramic insulators were the only damage reported for the site. The damaged insulators had been replaced, as illustrated above, within hours after the earthquake and before the reconnaissance visit.

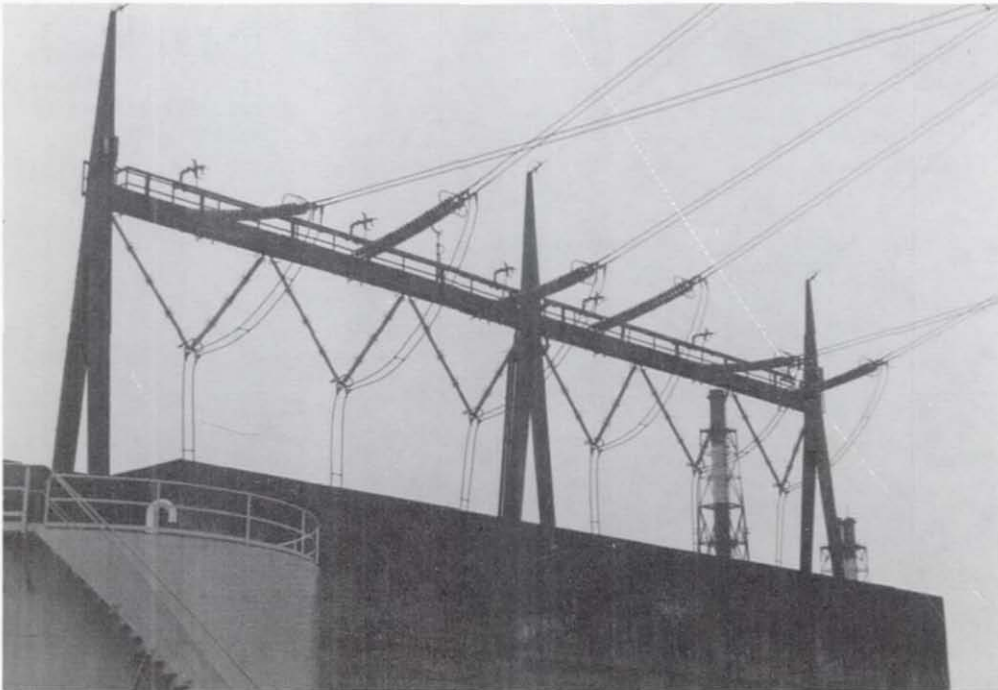

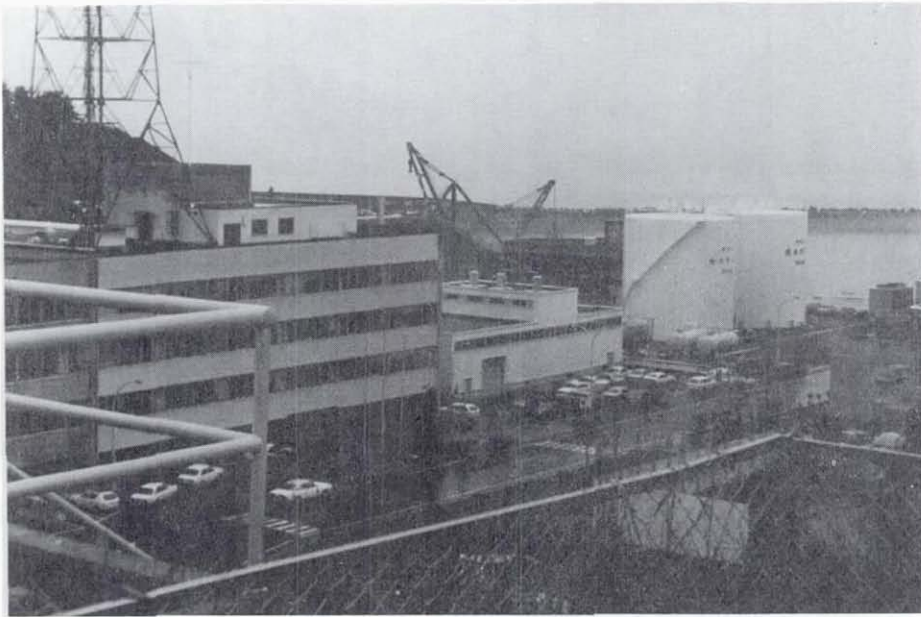

Figure 6.11 Fukushima Nuclear Power Plant: a view of some of the auxiliary structures to the north of Unit 1. Free-field acceleration was recorded in the water treatment building (the white, 1-story building in the middle of the photograph), which is located approximately 100 m from the Unit 1 containment structure. The SMAC instrument recorded a peak ground acceleration of approximately 0.125g.

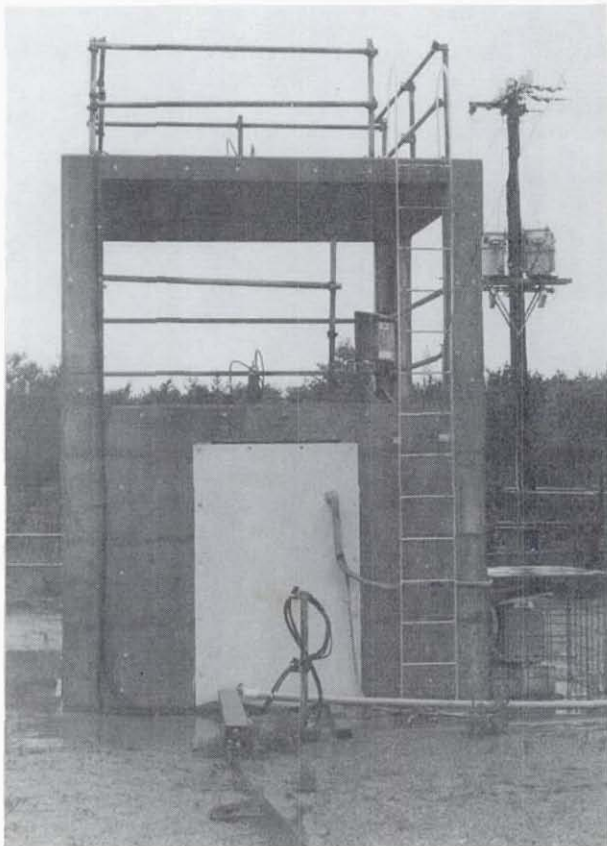

Figure 6.12 Fukushima Nuclear Power Plant: view of the 1/15th scale model of the containment of one of the nuclear units. The free field and downhole instrumentation is located away from the test structure (note the cables to the right).

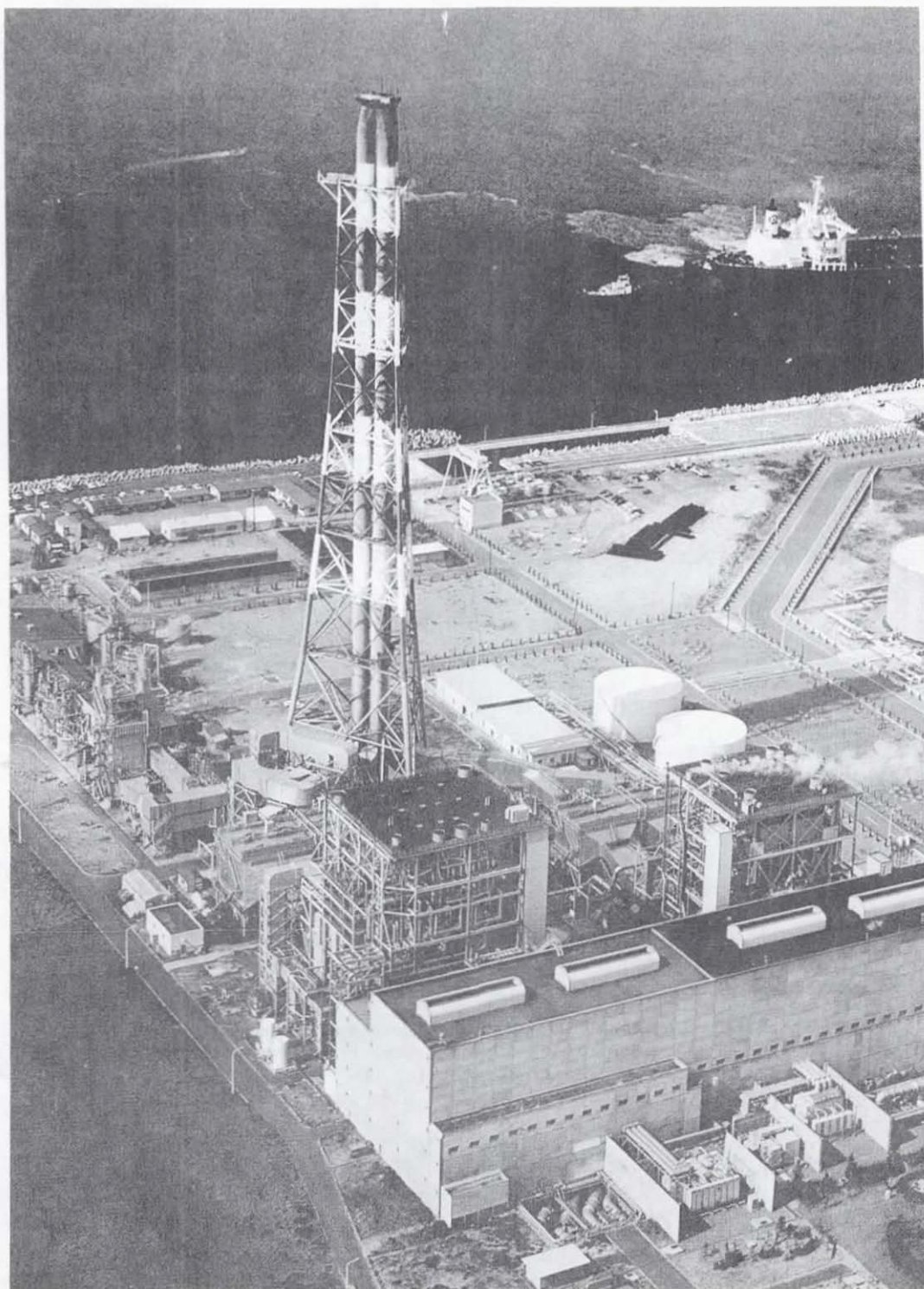

Figure 6.13 New Sendai Power Plant, Tohoku Electric Power Company: a general view of the two-unit, oil-fired power plant. The turbine building is in the foreground, and the two boiler structures are in the background. Unit 2, the large unit, has a 600-MW capacity. Unit 1 has a capacity of 350 MW. Note the massive seismic bracing to the combined stacks and to the boiler support frames. (Tohoku Electric Power Co. photograph)

Because the SMAC accelerograph at the station was being inspected at the time of the earthquake, no records were obtained. However, the plant's seismic alarm, located at the level of the turbine operating floor, was triggered at approximately 0.15g. Because the plant is closer to the epicenter of the earthquake and the assumed area of faulting (as discussed in Chapter 3), it may be assumed that the ground motion at the plant was somewhat stronger than in the city of Sendai where the recorded peak ground accelerations varied between 0.20 and 0.40g.

The plant is located in an area of recent alluvium and on filled land; the depth of unconsolidated sand is approximately 15 m (45 ft).

Both of the units were damaged during the earthquake, and the plant was shut down for 6 days for repairs. Total damage to the facilities of the Tohoku Electric Power Company is approximately \$15 million; estimated damage to the plant accounts for about 10 percent of the loss. The total assets of the company in property, plant and equipment for Fiscal Year 1976 were \$3,840 million. Damage from this earthquake caused a loss of about 0.4 percent of those assets. The plant was operating at the time of the investigation of June 24th, 12 days after the earthquake.

Three types of damage occurred at the plant: (1) damage due to local, minor settlement, (2) damage to the structural and architectural elements of buildings, which was minor, and (3) damage to the equipment, which constituted the bulk of the loss.

Minor settlement occurred throughout the site. Much of this settlement occurred in the vicinity of buried piping (Figure 6.14). About 1 cm of settlement occurred at the intake structure and the paving around the structures was cracked; however the structure was operational and did not seem to require repairs (Figure 6.15).

Building damage was limited to some of the interior walls of the administration building and to the facing precast panels of the turbine buildings (Figure 6.16). Some of these panels were loosened; presumably the attachments to the steel framing were damaged.

Both Unit 1 and Unit 2 suffered damage to tubing inside the boilers (Figure 6.17). A small furnace platen cooler tube inside the slag screen was sheared in the Unit 1 boiler (Figure 6.18). A similar failure occurred in the boiler of Unit 2 to one of the reheater spacer tubes. The suspended boilers and their structural supports also pounded against one another and also sustained some damage (Figure 6.19).

There was no other reported damage. The turbine pedestals and the operating floor of the turbine buildings in Japan are usually separated by a 3 to 4 inch gap and, in this case, there was no pounding between the two structures.

6.4 Sendai Substation, Tohoku Electric Power Company

The Sendai Substation of the Tohoku Electric Power Company is located on a low hill in the city of Izumi, about 7 km north-northeast of the center of Sendai. The substation is a large, multilevel complex. It was constructed during the last few years to the current Japanese seismic code, which specifies a minimum design acceleration of 0.20g for low-rise structures.

Figure 6.20 shows a general layout of the complex. The upper portion of the substation is the high-side 274 KV bus, and the lower portion of the substation is the low-side bus which is 154 KV. Locations of damage to equipment are circled in the figure.

Extensive cuts and fill were necessary because of the topography of the hill on which the station was located. The filled areas are indicated in Figure 6.20. Some of the fills, all of which were engineered, were as deep as 15 m (45 ft). The underlying bedrock is a competent, soft mudstone which was left exposed with slopes exceeding 60°. Due to seismic considerations, the most important electric components of the station were placed on the cut portions of the site, over a mudstone foundation. For example, all of the main transformers were placed on the cut sites, as shown in Figure 6.20. According to utility engineers, there seemed to be no difference in the amount of damage sustained by equipment whether on fills or on cuts. There was extensive damage to equipment in all parts of the facility. It



Figure 6.14 New Sendai Power Plant; Tohoku Electric Power Company: A view of the entrance area to the power plant showing settlement of fill and subsequent repair work to the pavement. The pavement settled approximately 15 cm (6 in) and was primarily in the vicinity of a backfilled underground pipeline.

Figure 6.15 New Sendai Power Plant, Tohoku Electric Power Company: damage around the water intake structure from minor settlement. Other examples of minor settlement were observed throughout the site.



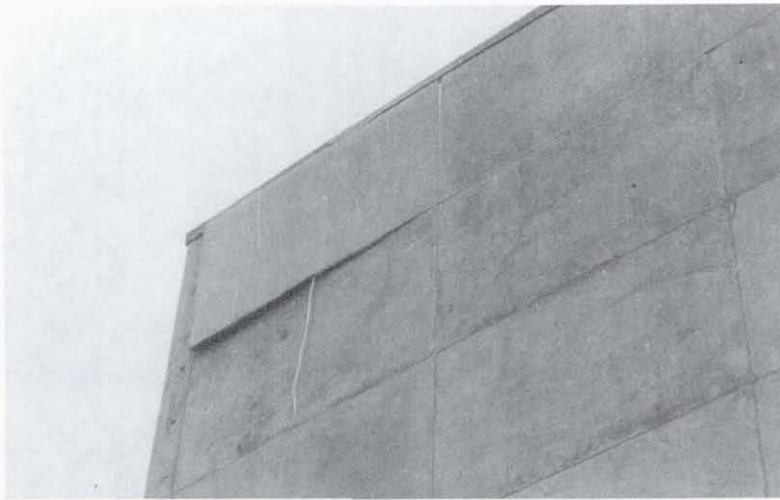
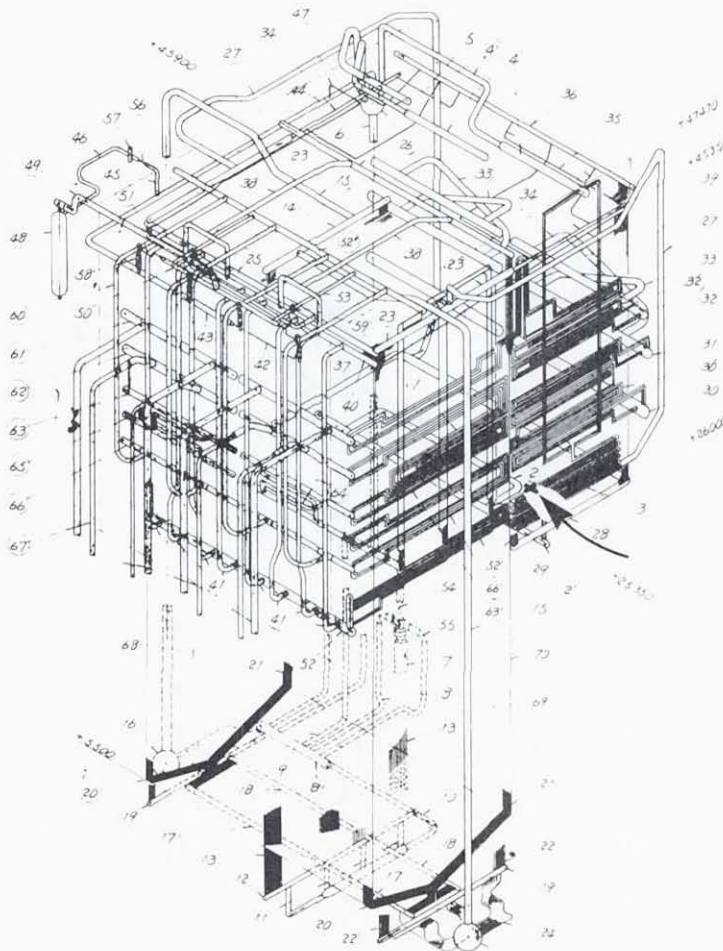

Figure 6.16 New Sendai Power Plant, Tohoku Electric Power Company: a loosened exterior facing panel in the turbine building. This was the only obvious damage to the exterior of the structure. The shear walls of the adjacent administration building showed extensive cracking.

Figure 6.17 New Sendai Power Plant, Tohoku Electric Power Company. The arrow points to the location of the damaged horizontal spacer tubes in the 600-MW boiler of Unit No. 2. (See Figure 6.18).



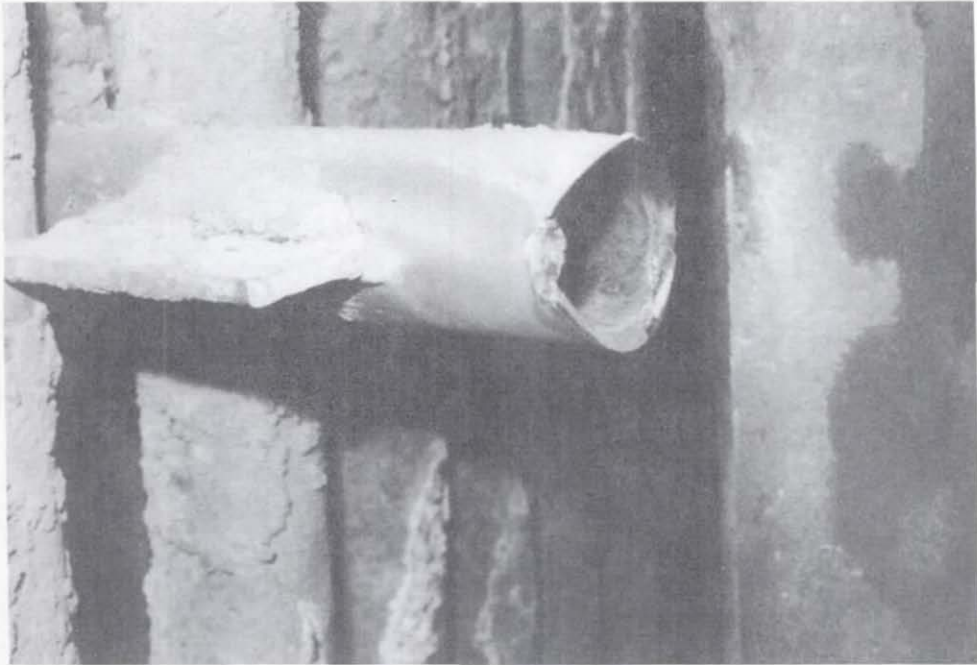

Figure 6.18 New Sendai Power Plant, Tohoku Electric Power Company: damage to the two boilers consisted of shearing of spacer tubes for the furnace platen cooler tubes inside the boiler. (Tohoku Electric Power Company photograph)

Figure 6.19 New Sendai Power Plant, Tohoku Electric Power Company: a view of the exterior of the boiler walls showing evidence that the suspended boiler had pounded against the surrounding support structure. (Tohoku Electric Power Company photograph)



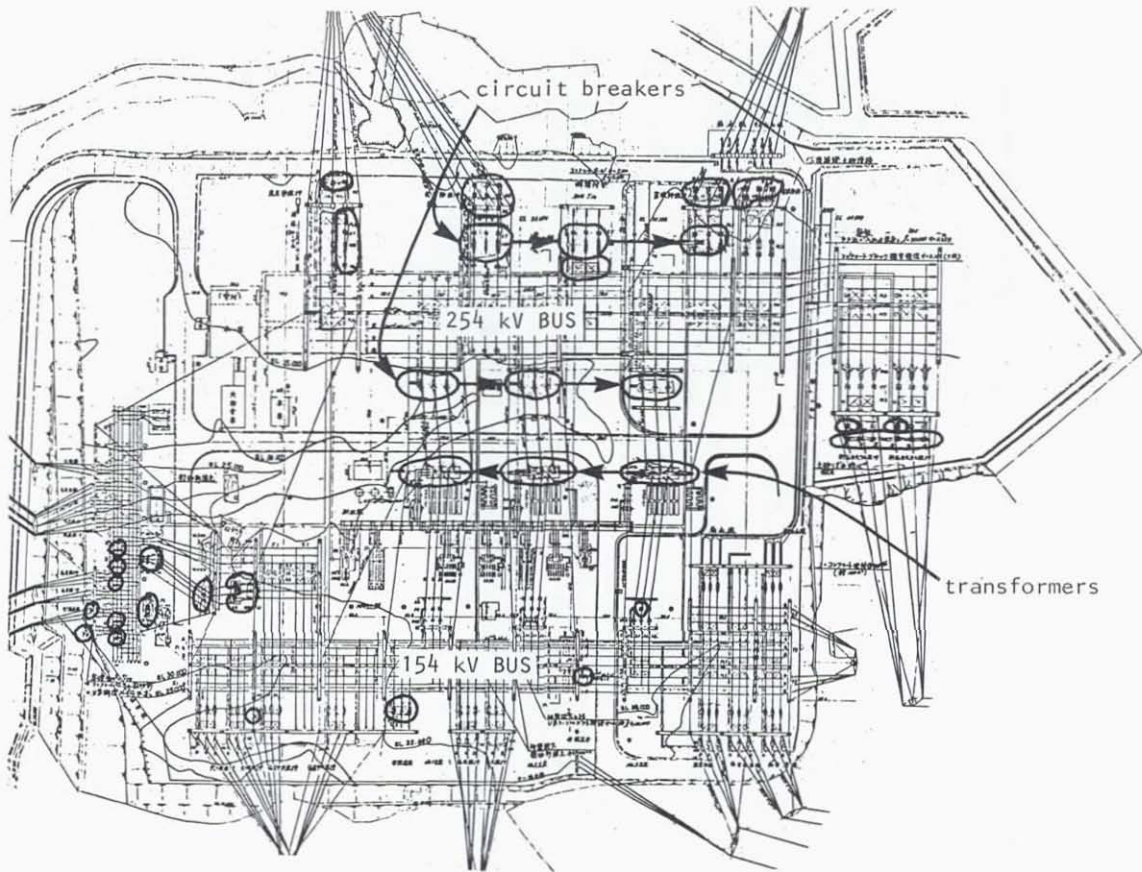

Figure 6.20 Sendai Substation, Izumi: plan of the facility showing the location of damaged equipment (circled). The solid contour lines indicate areas that were filled.

was immediately apparent during the investigation (June 24, 12 days after the earthquake), that all of the equipment was adequately anchored to its foundations, or braced. No overturning or other structural bracing failures were noted. Apparently, the damage was limited to various ceramic insulators in lightning arresters, potential devices, circuit breakers, transformers, bushings, reactors or line traps, switches, etc. Thus, there was a striking difference between the damage to this substation, as compared to the damage at the Sylmar Converter Station from the San Fernando, California earthquake of February 9, 1971. In the latter case much of the damage was caused by the overturning of equipment with inadequate anchorages or supports.

By June 24th much of the damage to the substation had been repaired (Figures 6.21 and 6.22), and the damaged equipment (Figures 6.23 through 6.27) had been dumped in piles on the periphery of the substation (Figure 6.28). Repairs were still going on to the bushings and lightning arresters of some of the main transformers (Figure 6.29), and various pieces of equipment had not yet been replaced. The total damage at the substation is estimated to be on the order of \$15 million.

A Japanese team has been assembled to conduct a special investigation of the performance of the substation during the earthquake.

6.5 Haranomachi Plant of Sendai City Gas Bureau

The Sendai City Gas Bureau's Haranomachi Plant, located approximately 3.7 km northwest of the center of Sendai, suffered major damage. The total collapse of a large propane gas holder (Figure 6.30) was partially responsible for the stoppage of gas for the city. It was estimated that gas services for the city would not be restored until the end of June, some three weeks after the earthquake. At the time of the investigation (June 25, 13 days after the earthquake) many restaurants in Sendai were closed because of lack of gas. According to Chapter 2 about 60 percent of the 200,000 households in Sendai are dependent on gas for heating and cooling, and as of June 28, 1978, 22,000 of these households were still without gas. An additional 10,400 households elsewhere in the prefecture were also without gas.

The holder diameter was 38 m; its height was 27 m. At the time of the earthquake, the holder contained 14,000 m³ of propane gas, at the relatively low pressure of 1 kg/m², and held water in a 9-m section at the bottom of the structure. The tank had at least two, but more probably three, telescoping sections constructed of riveted plate, 1 cm (3/8 in.) thick, stiffened with ring stiffeners at approximately 2 to 3 m. The tank was surrounded by an outside containment dike also constructed of riveted steel plate.

The collapsed holder caught on fire shortly after failure, and all of the stored gas was consumed. The fire burned out, or was extinguished, about 25 minutes later, and did not spread to the nearby high pressure propane tanks. The most serious damage to the gas facility was caused by the collapsing holder. It struck the nearby pipeway for many of the tanks at the plant, causing much damage to the piping systems and other associated equipment. Figure 6.31 shows the collapsed holder and the damaged pipeway just after the earthquake. At the time of the investigation a new pipeway had been erected on the concrete pedestals of the old pipeway, and repairs of the pipelines were proceeding, Figure 6.32. These pipes service the remaining undamaged gas tanks.

There was evidence of damage throughout the facility (Figures 6.33 through 6.38); however, none of the other tanks at the facility are believed to have suffered major damage. Some damage was due to pounding between buildings and pipes that penetrated the building walls (Figure 6.39). Unanchored pipe supports often moved on their pedestals, and reinforced concrete block structures suffered damage to their structural elements.

6.6 Sendai Refinery, Tohoku Oil Company Ltd.

Figures 6.40 through 6.49 give an overview of damage to the Sendai Refinery of the Tohoku Oil Company, Ltd., which is located on shore about 15 km east of the center of Sendai and adjacent to the New Sendai Power Plant. A plan of the refinery, which is a major installation and was completed in 1971, is shown in Figure 6.40. The refinery covers an area of 1,600,000 m². Its capacity is approximately 100,000 barrels/day.

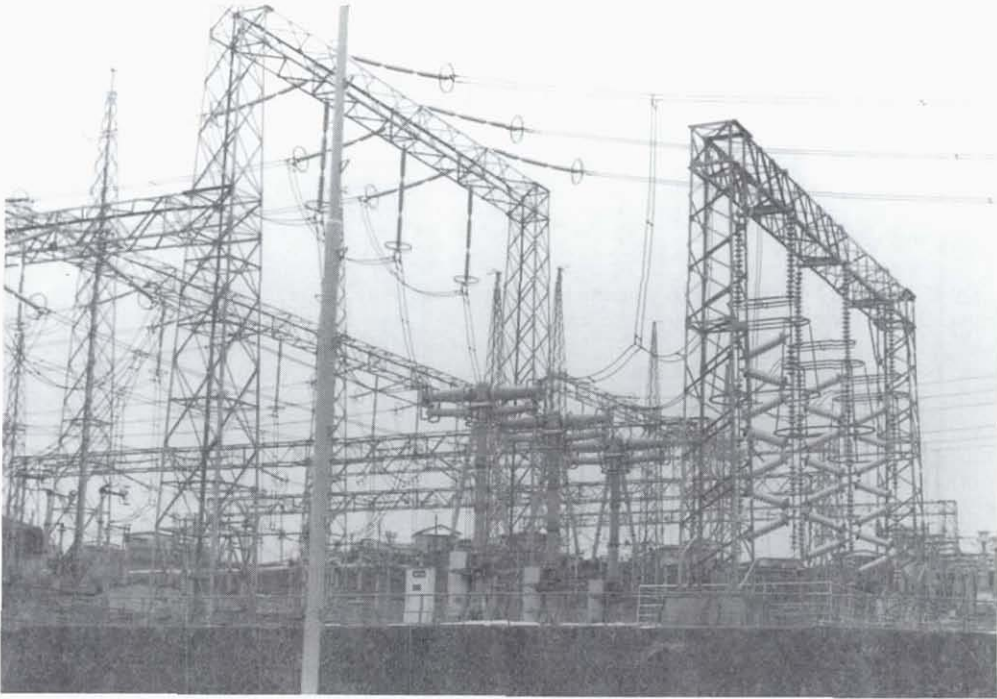
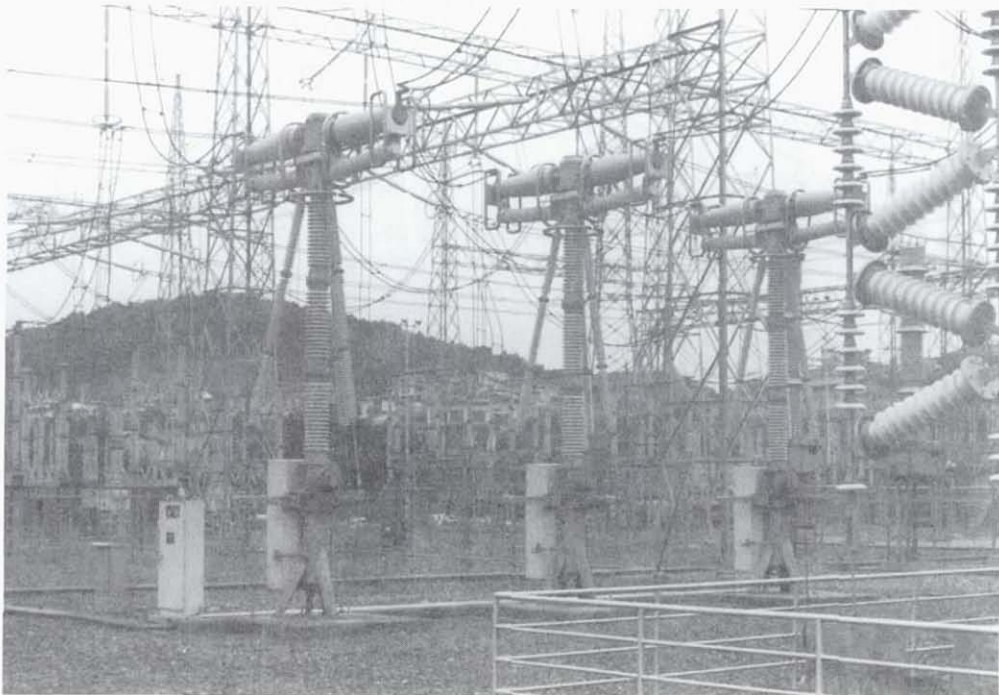

Figure 6.21 Sendai Substation, Izumi: a general view of a portion of one of the buses. Damage was not reported to these steel structures.

Figure 6.22 Sendai Substation, Izumi: three replaced 3-phase circuit breakers. This type of T-shaped circuit breaker suffered a high percentage of damage. Often the three symmetrical guides broke before the main stem. In all cases the structural steel supports appeared to be undamaged.



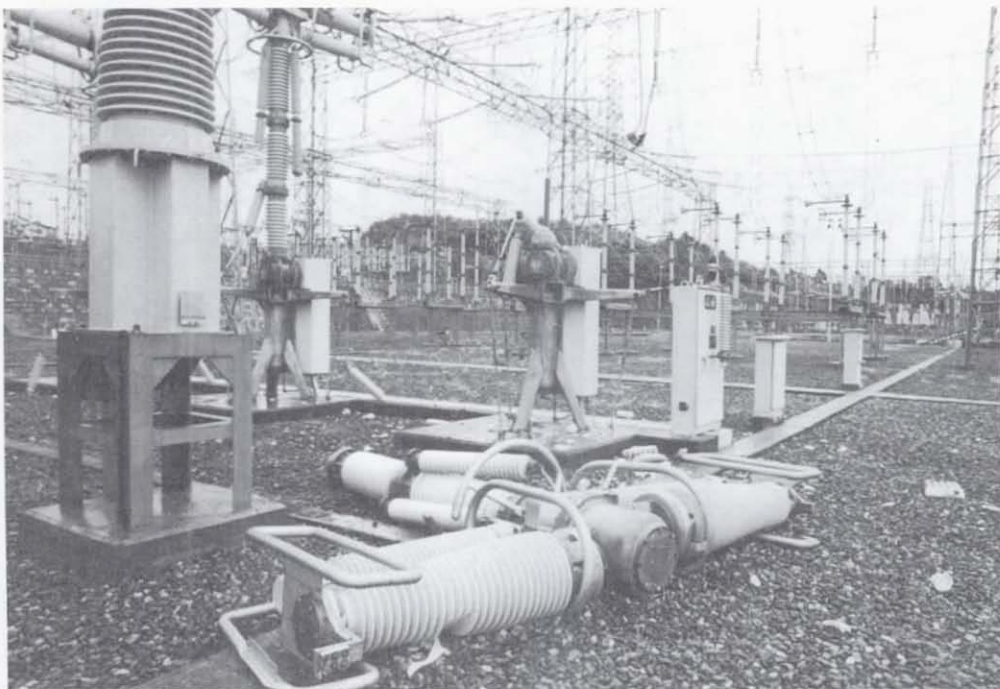
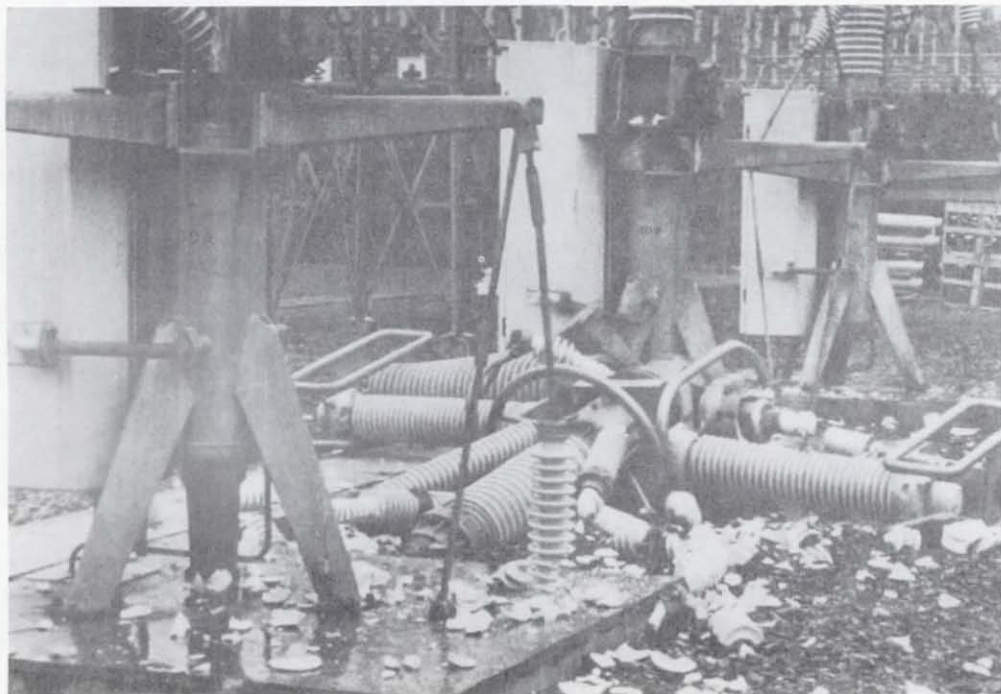

Figure 6.23 Sendai Substation, Izumi: typical damage to 3-phase T-shaped circuit breakers (as shown in previous figure). Note the complete failure of one and the damage to the three guides of the second circuit breaker. All steel supports appear to be undamaged. The photograph was taken immediately after the earthquake before repairs were initiated. (Tohoku Electric Power Co. photograph)

Figure 6.24 Sendai Substation, Izumi: another three failed 3-phase, T-shaped circuit breakers. Note the failed main stems, the loose guide wires and the undamaged steel supports which are attached to their foundations. (Tohoku Electric Power Co. photograph)



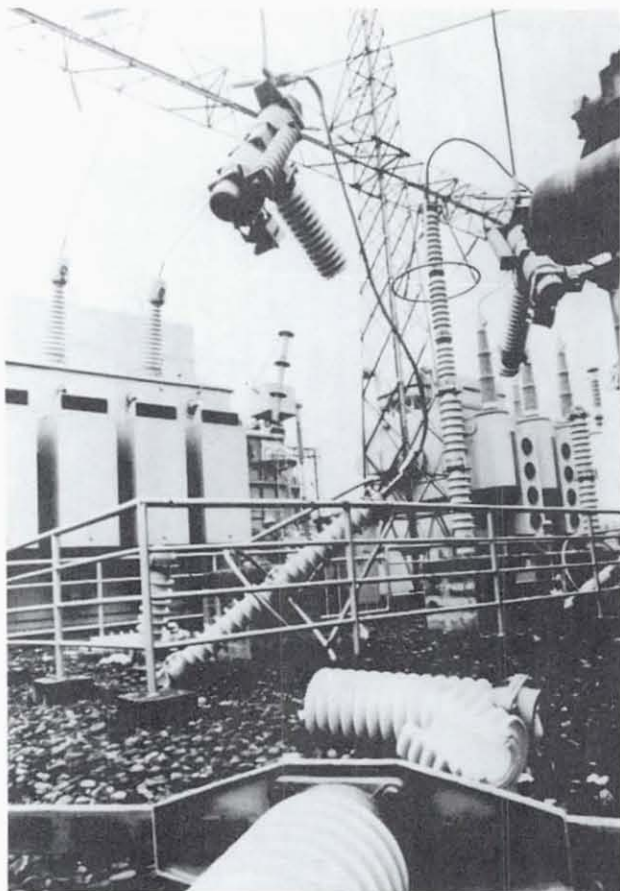
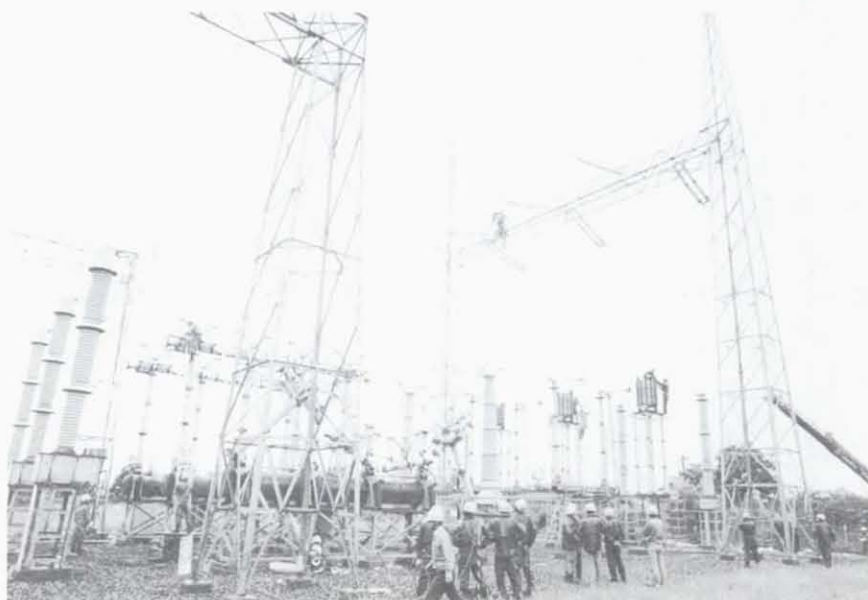

Figure 6.25 Sendai Substation, Izumi: damage to a circuit breaker (right), and two lightning arresters (center). The bushings of the transformer in the background appear to be undamaged; however, the lightning arrester is leaning. (Tohoku Electric Power Co. photograph)

Figure 6.26 Sendai Substation, Izumi: Severe damage to circuit breakers (center of photograph - note the failed columns of live tank design, probably with gas reservoirs), current transformers (with the tapered bushings - some of the stems are also damaged), and reactors (to the left) with presumably broken connections. (Tohoku Electric Power Co. photograph)



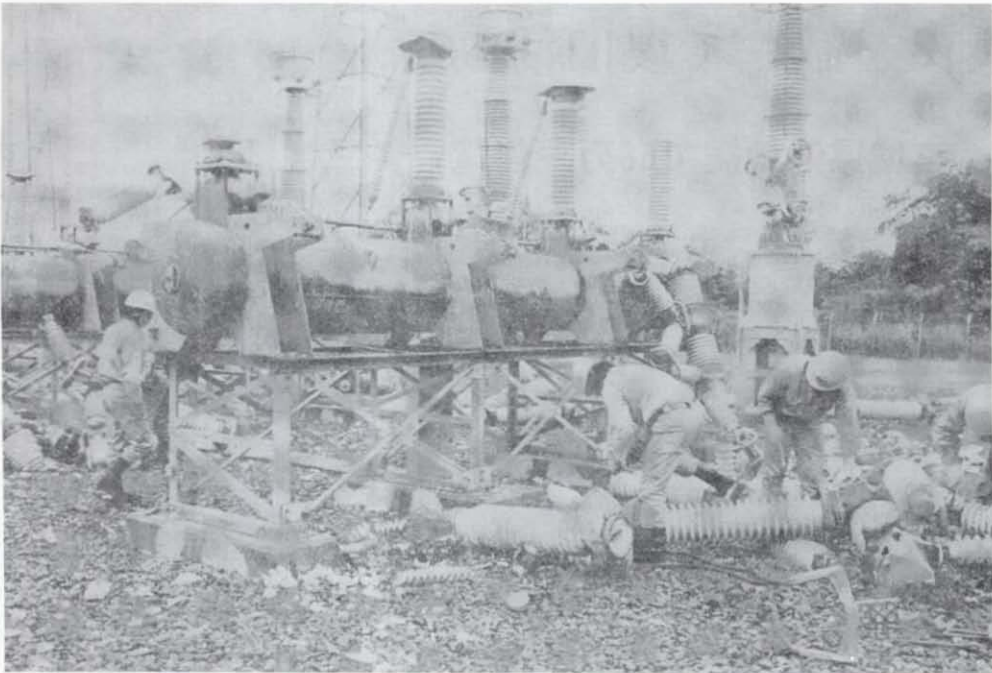
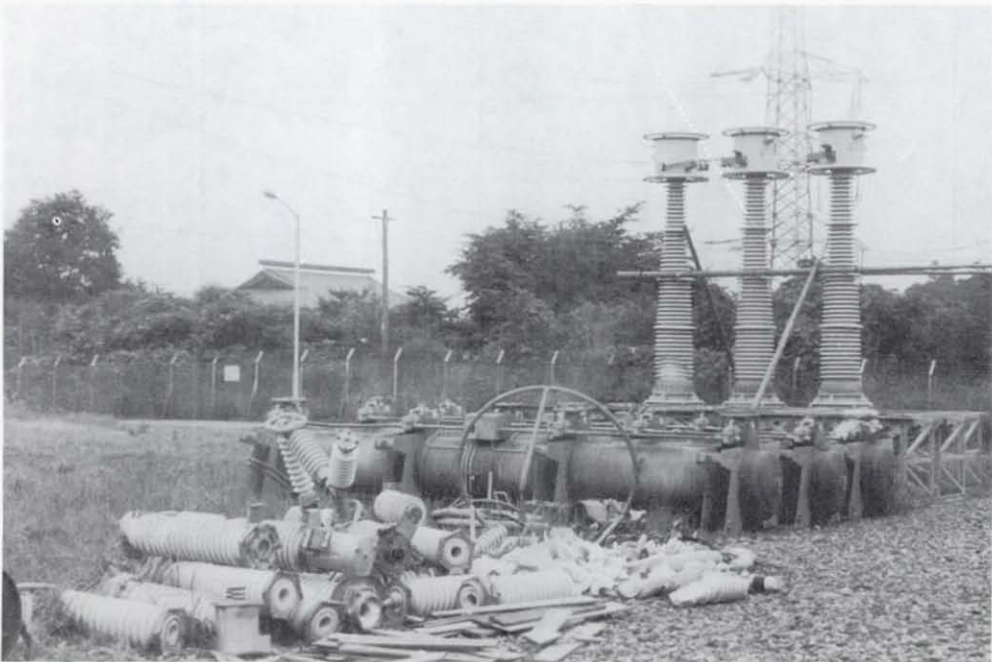

Figure 6.27 Sendai Substation, Izumi. Severe damage to several circuit breakers of live tank design. Note the lack of damage to the structural steel supports and the steel components of the equipment. (Tohoku Electric Power Co. photograph)

Figure 6.28 Sendai Substation, Izumi; one of several piles of broken equipment, including several line traps or reactors in the back (note the damaged base of the left stem) and the horizontal tanks of several circuit breakers of the live tank type (in the foreground are the failed columns of the circuit breakers and of other equipment).



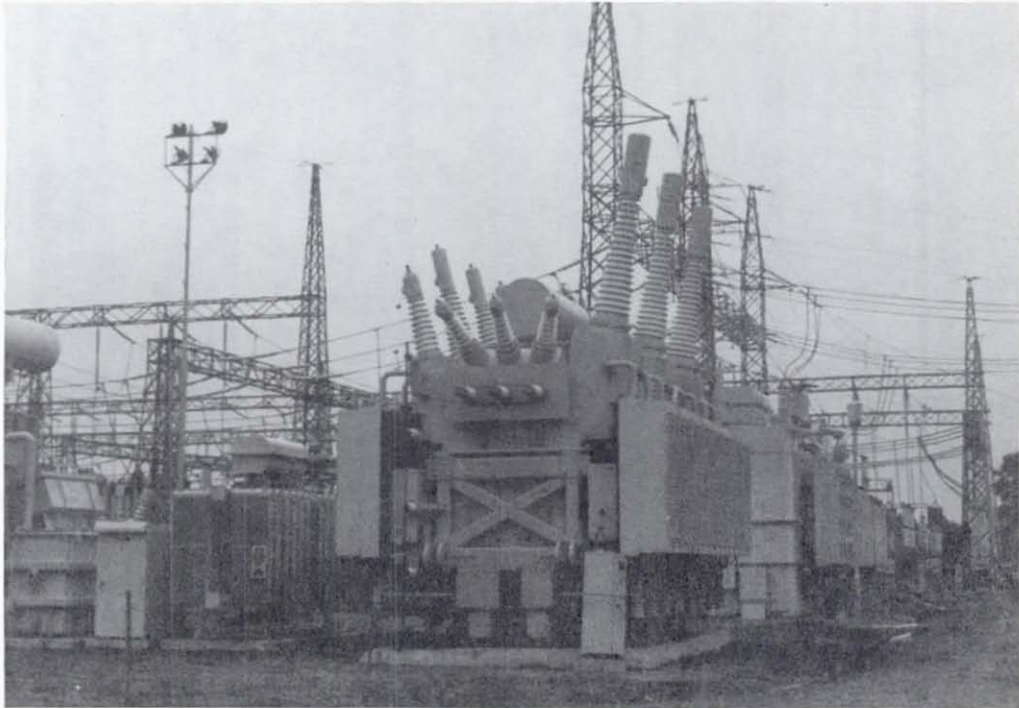
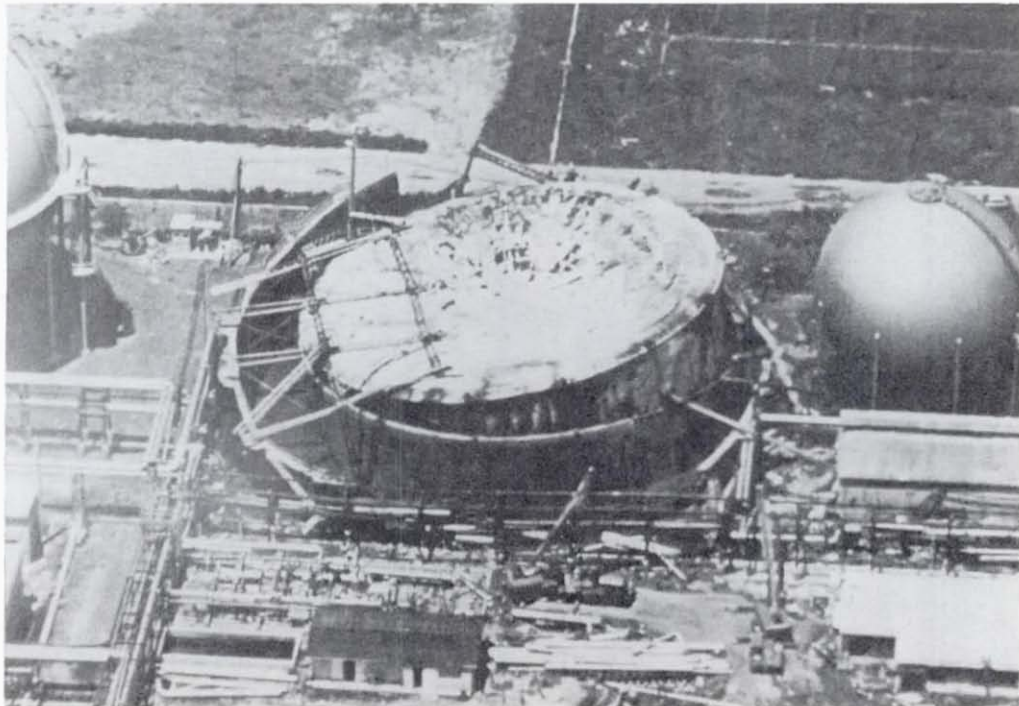

Figure 6.29 Sendai Substation, Izumi; a repaired but still disconnected transformer. All of the transformers at the substation lost some bushings or lightning arrestors. Some damaged parts were being replaced at the time of the investigation.

Figure 6.30 Haranomachi Plant, Sendai City Gas Bureau: an overall view of a collapsed propane gas holder and some of the surrounding propane storage tanks and affected pipeway and equipment. (Kahoku Newspaper Co. photograph)



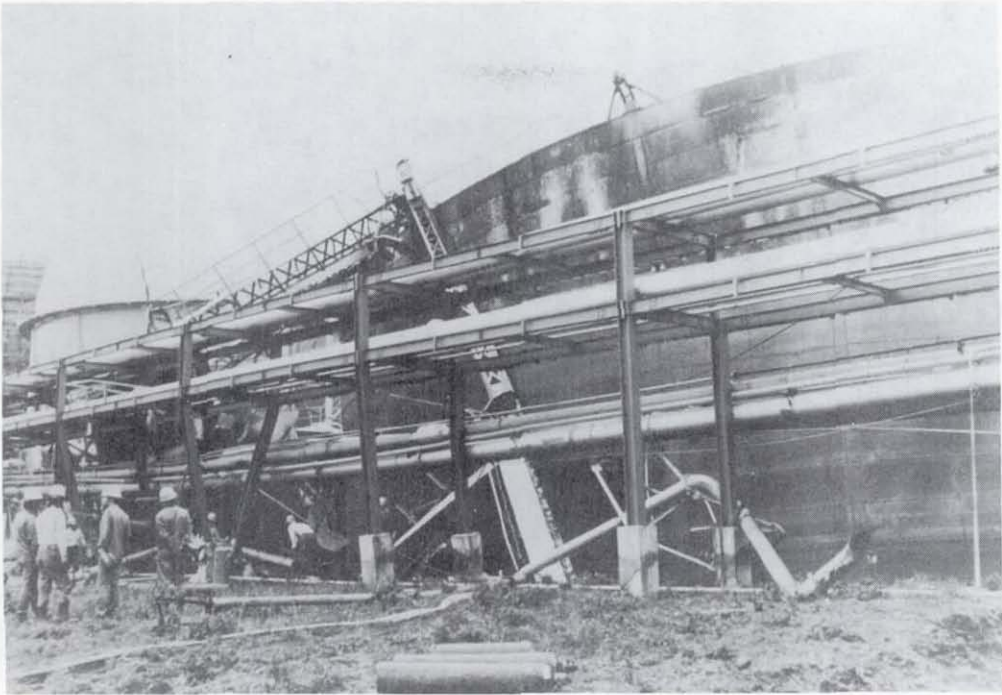
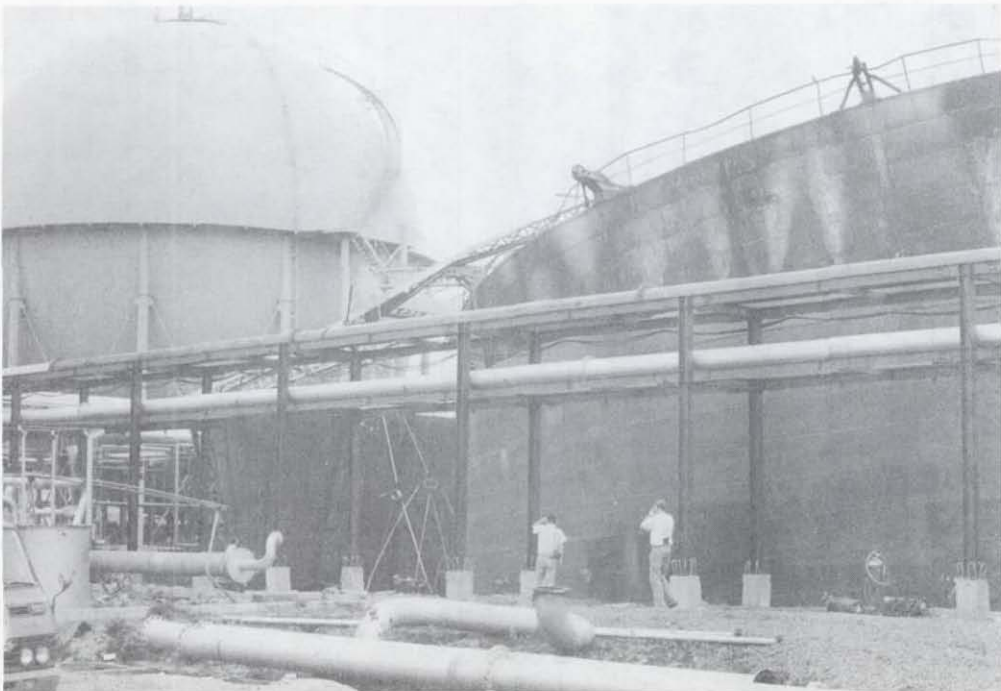

Figure 6.31 Haranomachi Plant, Sendai Gas Bureau; collapsed gas holder and the damaged adjacent pipeway structure just after the earthquake, (Sendai Gas Bureau Photograph)

Figure 6.32 Haranomachi Plant, Sendai City Gas Bureau: The newly erected pipeway, with the collapsed holder in the background. Note the undamaged pressurized propane gas sphere in the back.



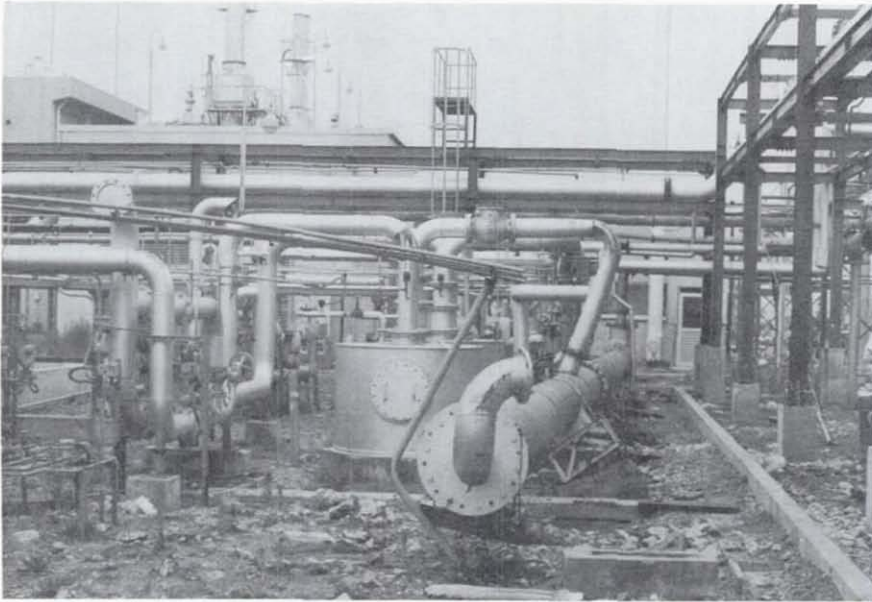

Figure 6.33 Haranomachi Plant, Sendai City Gas Bureau: damage to piping and other equipment and supports caused by impact from the collapsed gas holder and the adjacent pipeway. The newly erected pipeway is to the right.

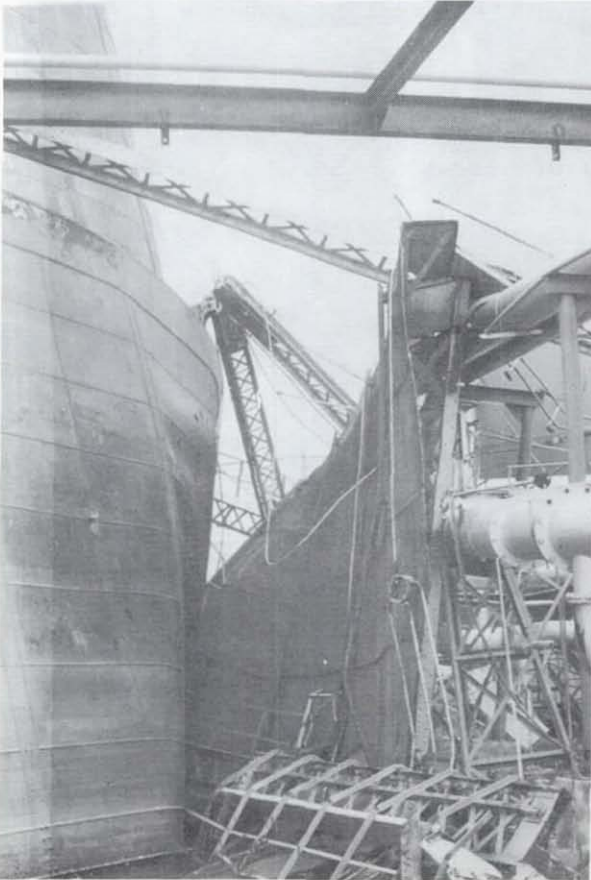
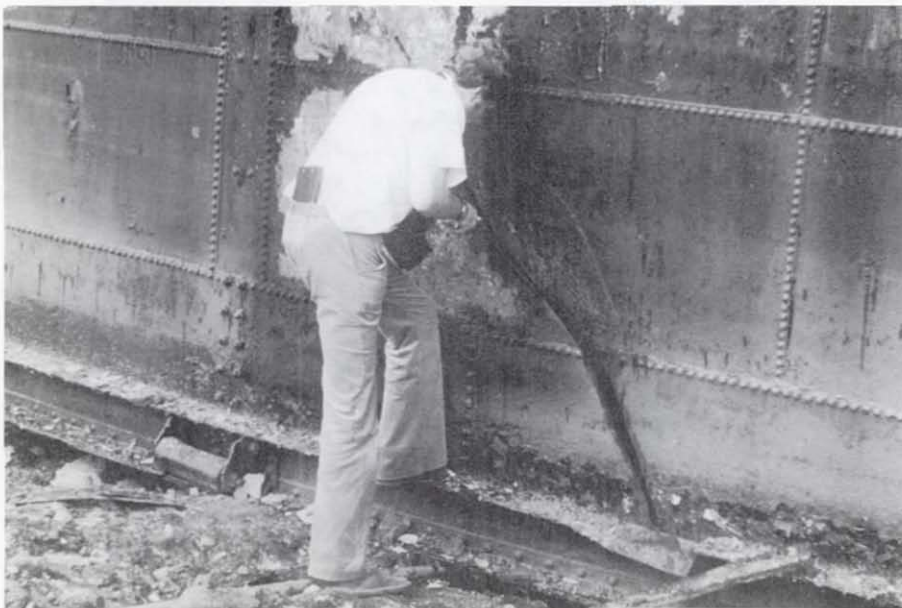

Figure 6.34 Haranomachi Plant, Sendai City Gas Bureau: damage to the telescoping gas holder and to some of the nearby pipeways and equipment. The trusses are portions of the original support structure that had surrounded the tank.



Figure 6.35 Haranomachi Plant, Sendai City Gas Bureau: buckling damage to the lower portion of one segment of the gas holder.

Figure 6.36 Haranomachi Plant, Sendai City Gas Bureau: a fracture of the 3/8-in. plate wall of the collapsed gas holder. The length of the fracture is approximately 1.5 m (5 ft).



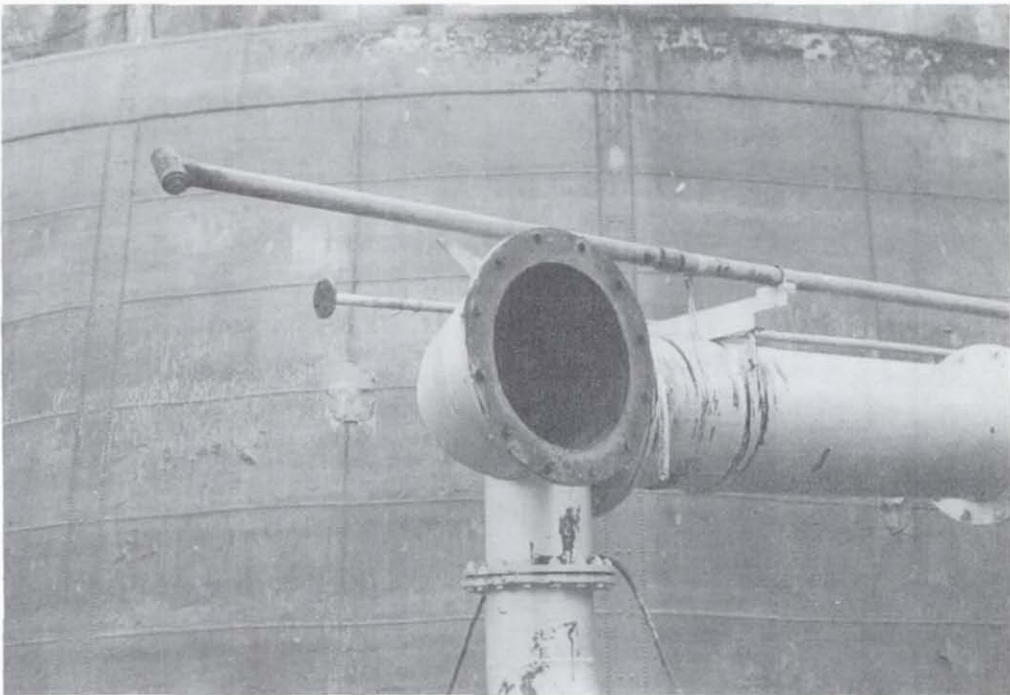
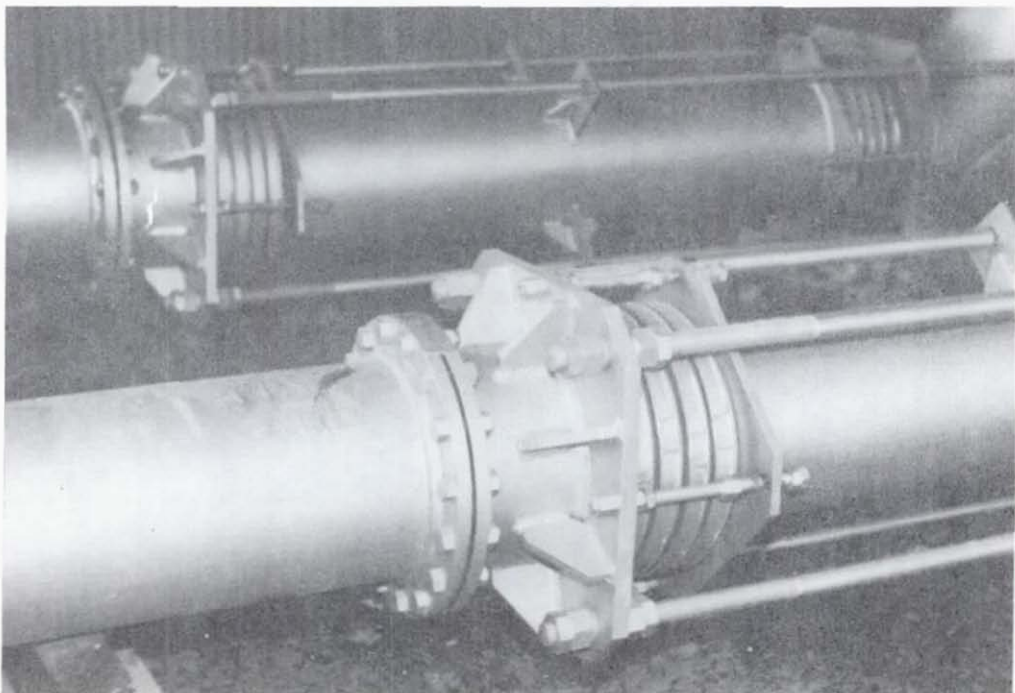

Figure 6.37 Haranomachi Plant, Sendai City Gas Bureau: sheared pipe flange connections in the pipeway structure in the vicinity of the collapsed gas holder.

Figure 6.38 Haranomachi Plant, Sendai City Gas Bureau: undamaged expansion bellows that moved several inches during the earthquake.



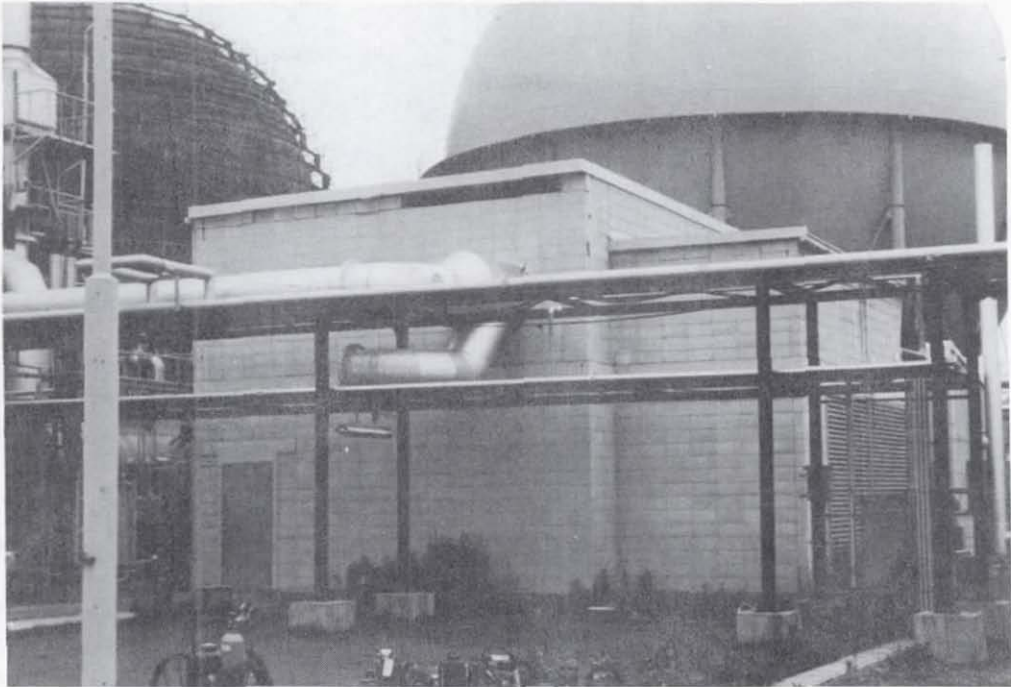

Figure 6.39 Haranomachi Plant, Sendai City Gas Bureau: a damaged reinforced concrete block structure. Some of the damage was due to pounding between the large diameter pipe and the structure at the pipe penetration.

Figure 6.40 Plan of the Sendai Refinery, Tohoku Oil Company, Ltd. Tanks are shown as circles in the plan. The circles that represent the three failed TC tanks have been blackened; ones that represent the three other damaged tanks are marked with an X. The refinery structures are located to the right of the tank farms.



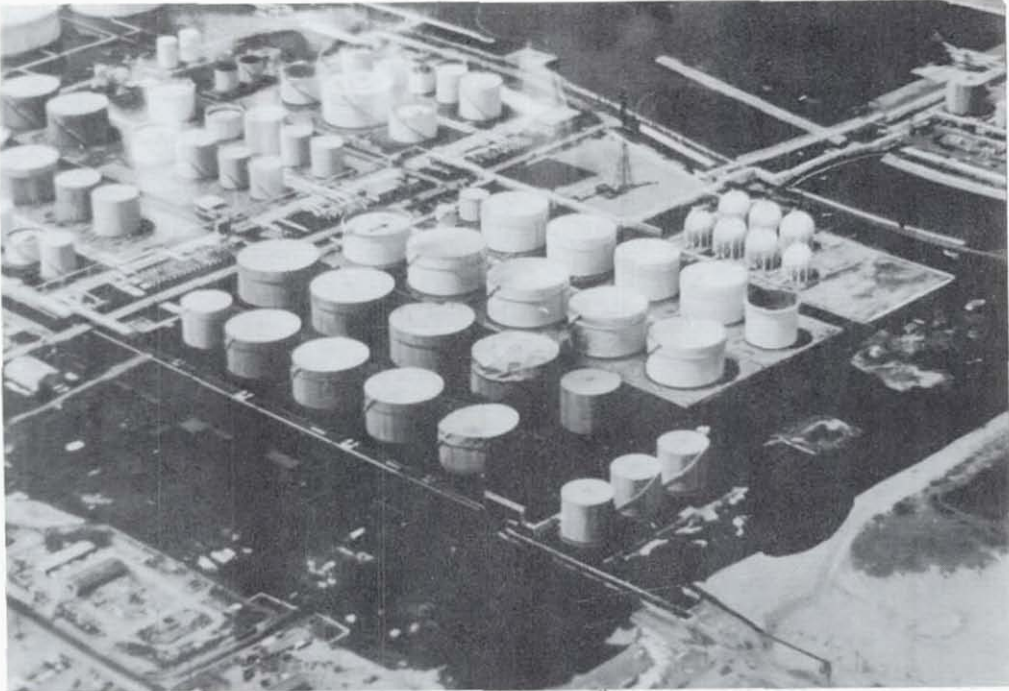

Figure 6.41 Sendai Refinery, Tohoku Oil Company, Ltd.: an overall view of the refinery's tank farm. The spilled oil appears as the dark area of the photograph. (Tohoku Oil Company photograph)

Figure 6.42 Sendai Refinery, Tohoku Oil Company, Ltd.: one of the three failed storage tanks. The damage illustrated is due to suction caused by rapid evacuation of the oil through the ruptured connection of the base and wall of the tank. The several tanks, of similar size, in the foreground are thought to be undamaged.

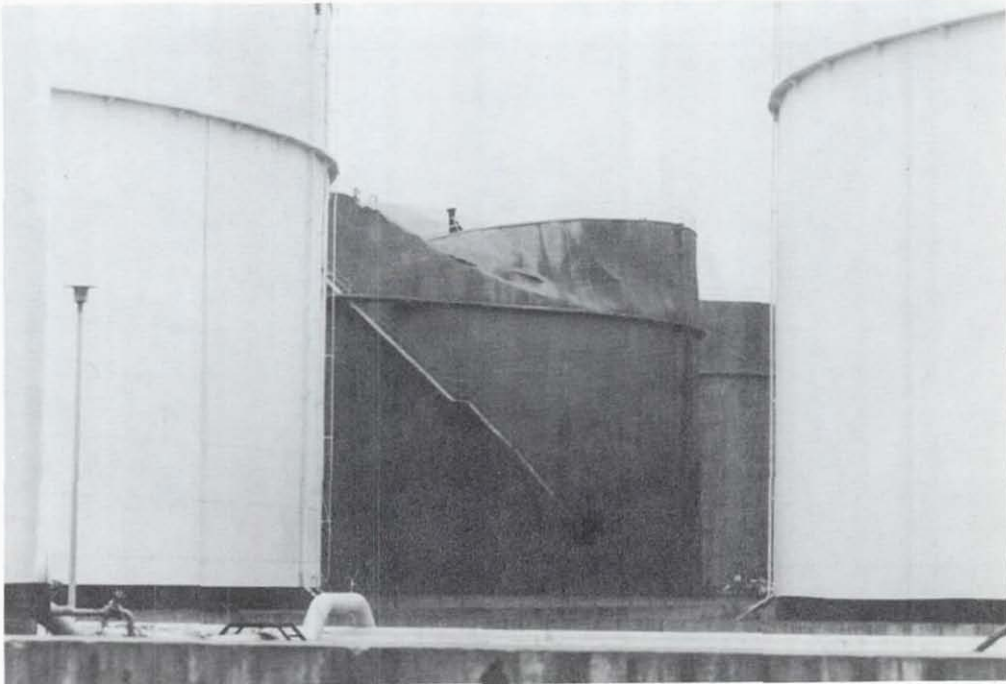
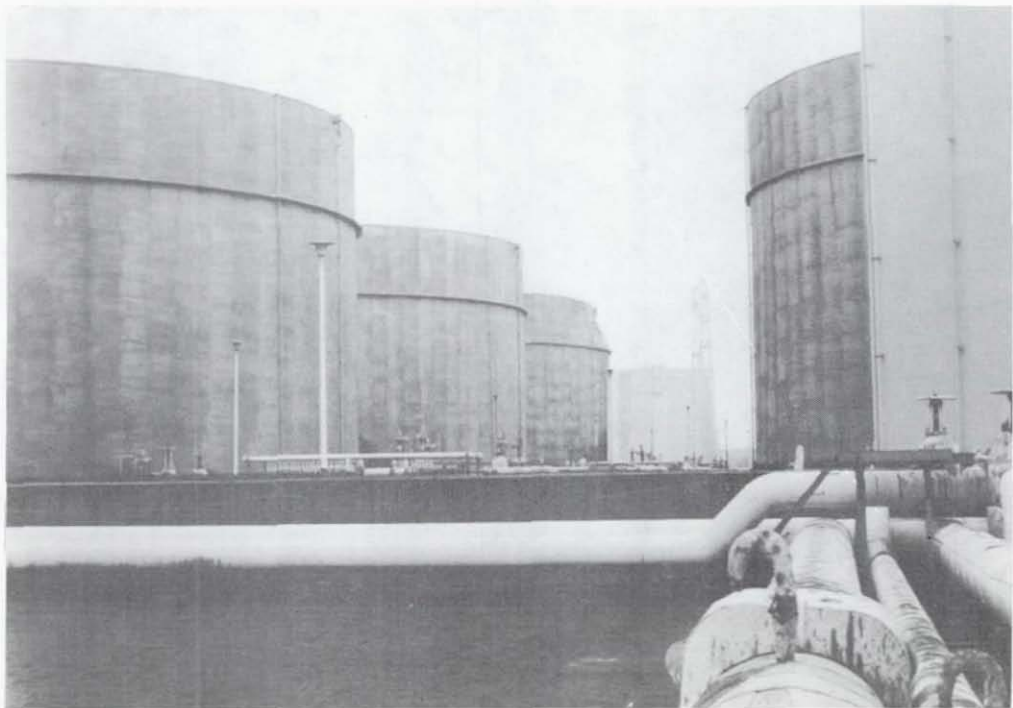



Figure 6.43 Sendai Refinery, Tohoku Oil Company, Ltd. Two other failed TC oil storage tanks.

Figure 6.44 Sendai Refinery, Tohoku Oil Company, Ltd. TC oil storage tanks.



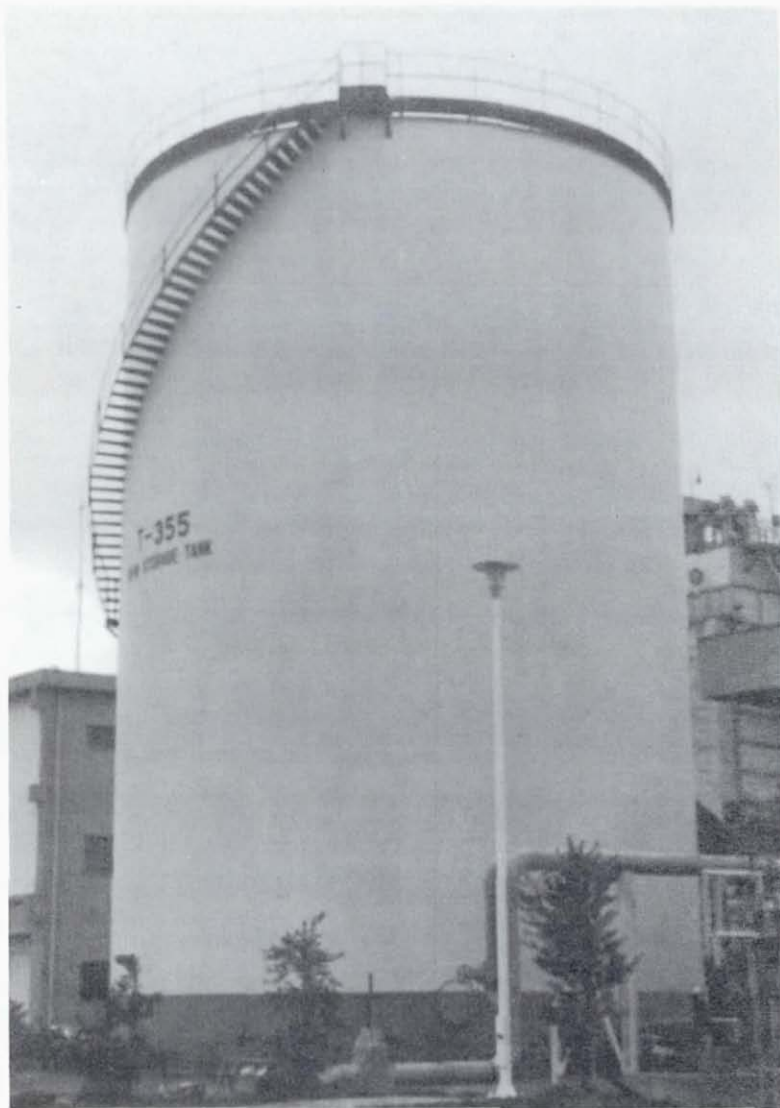

Figure 6.45 Sendai Refinery, Tohoku Oil Company, Ltd. A large water storage tank (left) near the main refinery complex appeared to have experienced significant rocking. Detail (right) of one of the pulled-out, or stretched, anchor bolts of the water storage tanks shown at left.

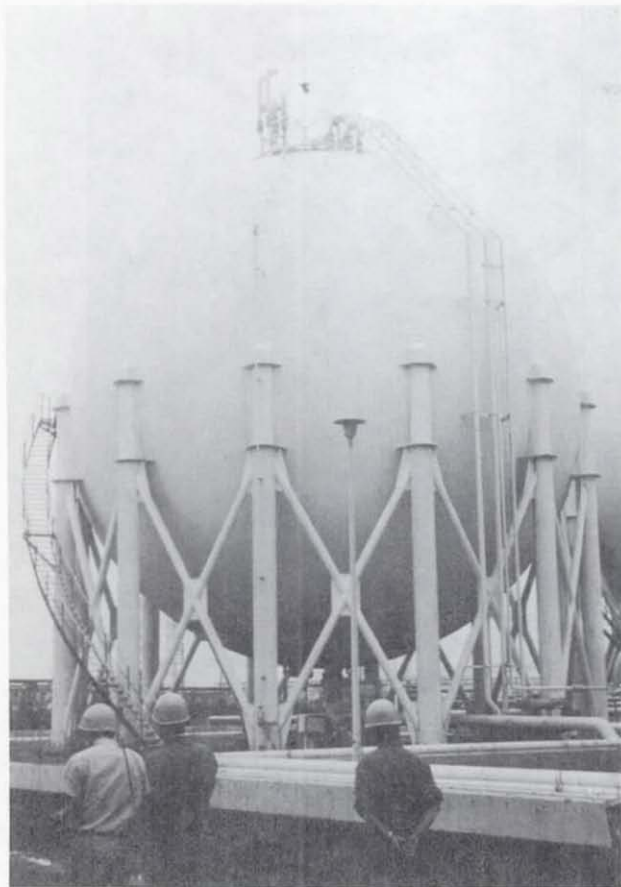
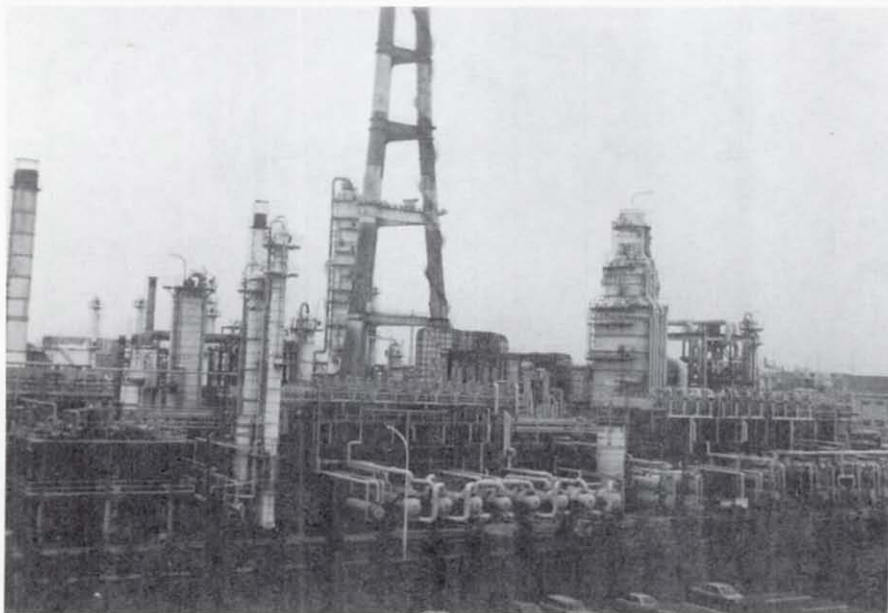

Figure 6.46 Sendai Refinery, Tohoku Oil Company, Ltd.: an undamaged LPG storage tank. Note the heavy diagonal bracing in the supporting structure.

Figure 6.47 Sendai Refinery, Tohoku Oil Company, Ltd.: a partial view of the refinery.



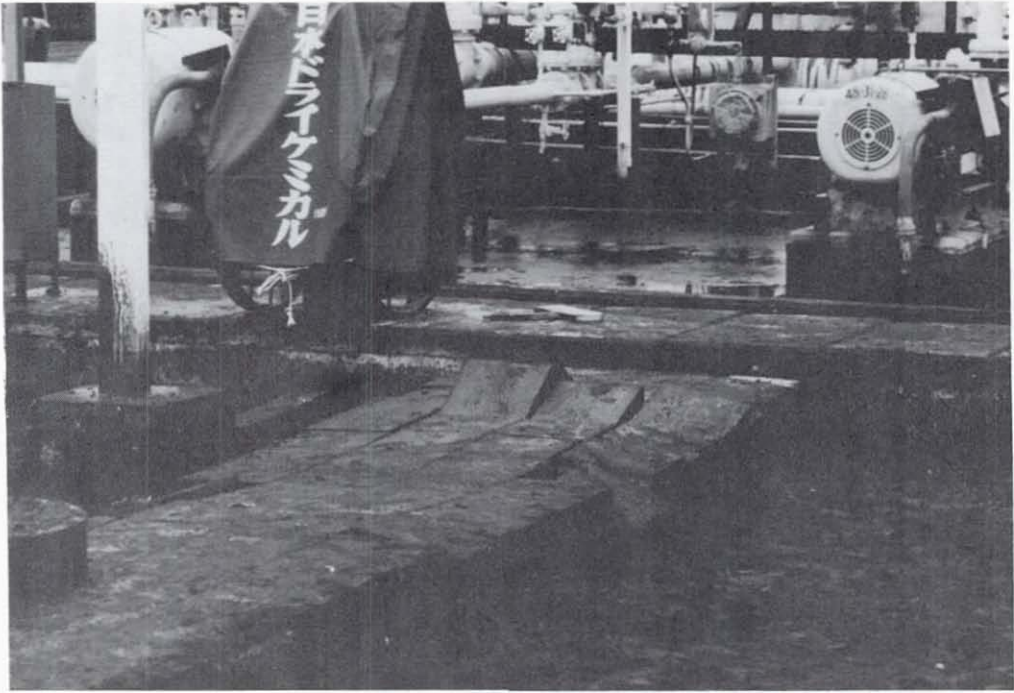

Figure 6.48 Sendai Refinery, Tohoku Oil Company, Ltd.: ground settlement at the refinery.

Figure 6.49 Sendai Refinery, Tohoku Oil Company, Ltd.: A wing of the damaged steel-framed administration building. Damage was obvious only to the architectural finishes.



As illustrated in Figure 6.40, the complex is divided in two parts by a river and some port facilities. The new Sendai Power Plant is to the east (right). The tank farms and the refinery complex itself are located on the eastern portion, adjacent to the port facilities, which can handle super tankers. The gas producing and pumping facilities are located on the western half of the complex. The land transportation facilities are also located on the west side.

The damage of the refinery and the lost oil represent one of the major losses from the Miyagi-ken-oki earthquake. At the time of the investigation (June 24, 12 days after the earthquake) the total amount of damage was unknown, as investigations were still continuing. It was expected that the damage investigations and evaluations by the company and the local fire authorities would continue well into July. The reported intensity at the site was 5 on the JMA scale, and the epicentral distance is approximately 100 km. The adjacent power plant had an accelerometer, which did not operate, and a seismic alarm, located at the turbine building operating floor, which was triggered by the earthquake. As the alarm was set at approximately 0.15 g, the motion was probably in excess of 0.15 g. In all probability, the motion exceeded 0.25 g.

The investigation revealed that the complex had been designed to reasonable seismic criteria. All of the observed tanks, equipment and piping systems were anchored and no overturning failures were observed. As discussed further, some of the tanks were designed for a 0.30 g peak ground acceleration. Major portions of the facility were located on engineered fill. There was some evidence of settlement, however it could not be determined if the settlement had occurred in filled areas.

There are at least 87 storage tanks in the facility. The tanks have different designs, and different functions; some stored oil, others stored liquid propane gas (LPG); some had fixed roofs, others had movable roofs. Three large tanks containing refined fuel called Top Crude (TC) failed, spilling approximately 68,100 kl of oil. The capacity of the tanks was 85,000 kl. The surrounding reinforced concrete dike could accommodate only 35,000 kl. The oil overtopped the dike, inundated much of the refinery area, and spilled over into the port (Figure 6.41). Because the surface soils are sandy, it is believed that much of the oil that was contained in the dike subsequently leaked under the walls and contributed to the spill.

At the time of the investigation a thick film of oil still covered much of the refinery grounds. Thus, the fire hazard was great, and the investigating team was unable to observe the details of the damage to the tanks. It is believed that the tanks shown in Figures 6.42 through 6.44 failed at their bases. The oil drained rapidly, causing a vacuum inside, which imploded the tanks. Three other tanks suffered damage and will need repair.

Another large water storage tank experienced interesting damage (Figure 6.45). The welded steel plate tank was anchored with bolts, spaced at approximately 6 ft (2 m), and embedded in a continuous concrete pad. The bolts around the entire circumference were stretched, or more likely, pulled out from their embedment from 1 to 6 in (2.5 to 15 cm). However, there was no apparent buckling or other damage to the steel base of the tank.

Visual inspection of several of the LPG tanks at the refinery, revealed no damage. There were minor cracks in the concrete supports and some spalling of paint in the steel connections due to working. The tanks were designed for 0.30g peak ground acceleration. As illustrated in Figure 6.46, the tanks were heavily braced with diagonal braces with circular cross-sections.

Figure 6.47 shows a partial view of the refinery, including several towers, heaters, boilers and a heavily braced steel stack. These structures are reportedly undamaged. The team was able to view some of the lower structures; no structural damage was observed. At the time of the reconnaissance, most of the equipment within the refinery complex had not yet been checked for operability. There was concern that some of the control equipment, and other minor operating equipment might have been damaged. Local settlements may have damaged some equipment, as illustrated in Figure 6.48. The pipeway support structures that were examined showed no significant damage.

Most of the refinery was shut down during the earthquake for its annual inspection. Thus a serious fire hazard from the spilled oil fortuitously was averted. During the investigation, the company was checking much of the equipment throughout the complex for damage, and a large scale clean-up effort was under way. The seriously damaged tanks were still not approachable because of the spilled oil.

6.7 Concrete Batch Plant, Sendai

This concrete batch plant is probably a representative small facility for the many thousands of similar (in size) industrial or manufacturing establishments in the metropolitan area of Sendai. It was operating at the time of the investigation. The facility sustained various types of structural damage to equipment and tank supports, buckling of storage tank walls, damage to structural steel framing, etc. It is very possible that this damage (and damage to similar small facilities), was not reported and is not included in the preliminary damage statistics that were available to the UJNR team members. The plant was inoperable for two days after the earthquake while repairs were being carried out. Because most of the damage was to structural steel braces, it apparently was easily repairable. In many cases the bolted connections of the braces to the vertical load carrying supports were sheared. Repairs were usually of two types: (1) the undamaged braces were realigned and the braces were welded to the gusset plates (in lieu of the previous bolting) and (2) damaged (presumably buckled) braces were replaced with new members, which were also welded in place (Figures 6.50 and 6.51). The most remarkable feature of the repairs was how quickly the work was completed, particularly at a time when skilled labor was presumably in short supply. Some serious structural damage had not yet been corrected at the time of the investigation; however, that damage was not to operating equipment and did not affect the day-to-day production. Except for some of the foundations and lower supporting structures, which were not damaged, all of the structures, tanks, and equipment at the site are made of steel.

A large welded steel plate storage tank, containing sand and gravel, and reportedly full during the earthquake, which was supported on a massive concrete pedestal, suffered buckling along several locations at the base of the steel plate (Figures 6.52 and 6.53). It seems apparent that the buckling was caused by overturning forces, rather than by sloshing of the contents. The tank and its superstructure and support structure did not experience any other damage.

One of the light steel-framed structures at the plant was damaged, as shown in Figure 6.54, apparently because of inadequate lateral bracing. The differential displacement caused by the failure of the structure was responsible for damage to a connecting vertical steel stack and associated piping. The stiffer first floor reinforced concrete structure was undamaged. A similar structure, Figure 6.55, located in the immediate vicinity of the plant and properly braced with light steel cable or rod braces, did not suffer damage. The latter type of construction is quite common in Sendai, and generally appeared to experience no significant damage.

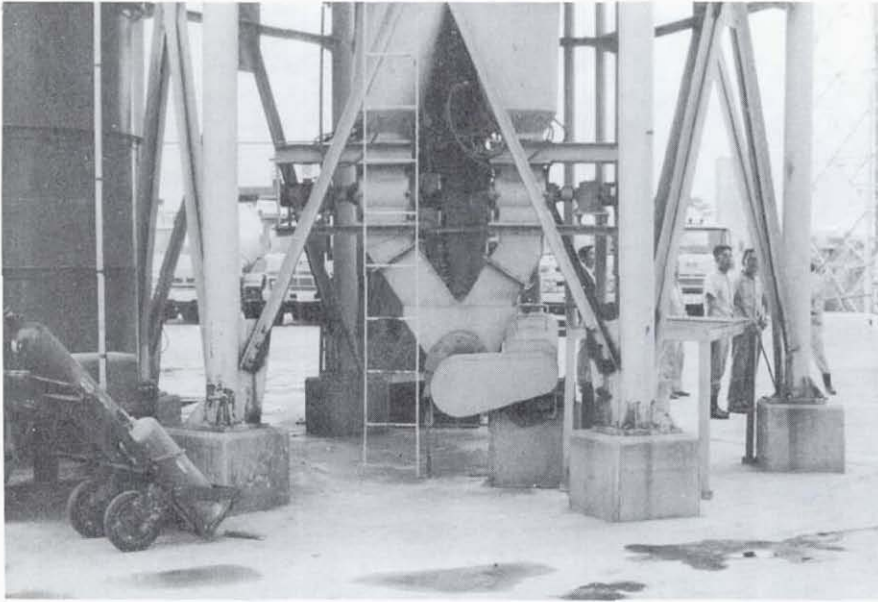

Figure 6.50 Concrete Batch Plant, Sendai: view of the repaired supporting substructure of a cement bin and related equipment. The sheared bolts at the brace connections have been removed and the braces have been welded to the gusset plates. Some of the buckled braces have been replaced entirely.



Figure 6.51 Concrete Batch Plant, Sendai: a detail of a replaced, and presumably buckled, diagonal brace. A number of similar repairs were carried out within two days after the earthquake.

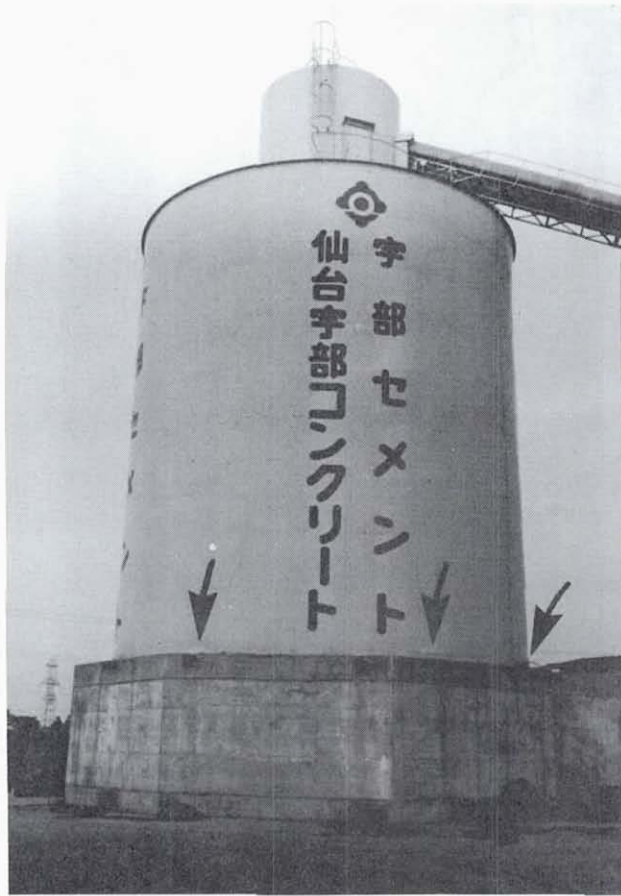
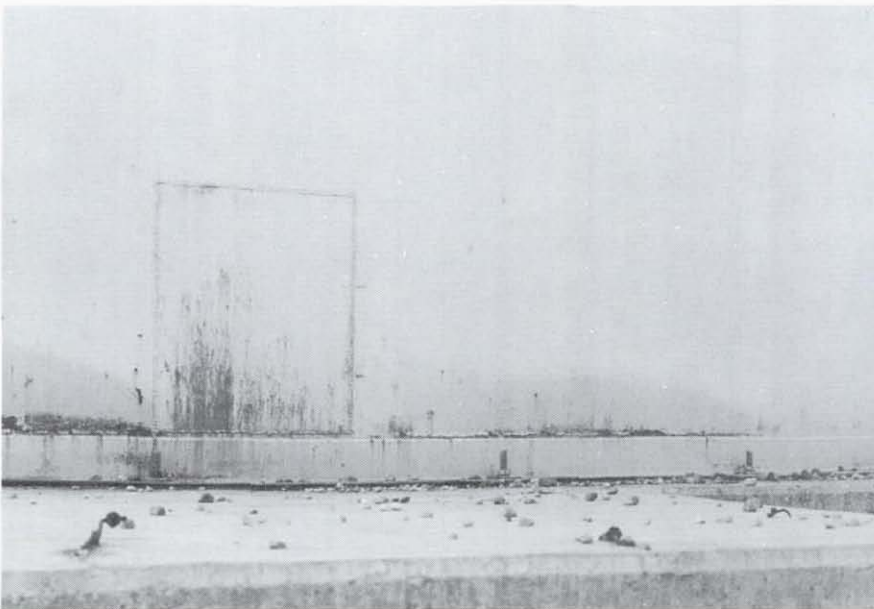

Figure 6.52 Concrete Batch Plant, Sendai: a large gravel-and-sand-storage tank experienced buckling of the welded steel plate at its base.

Figure 6.53 Concrete Batch Plant, Sendai: a detailed view of the damaged base of the sand and gravel storage tank. Note the closely spaced anchor bolts. Similar damage occurred at several locations along the circumference.



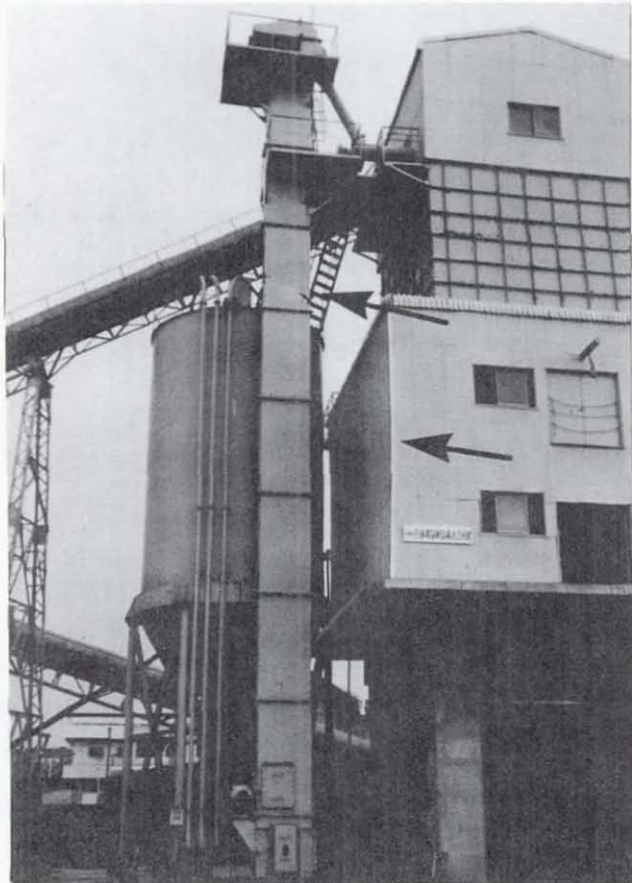
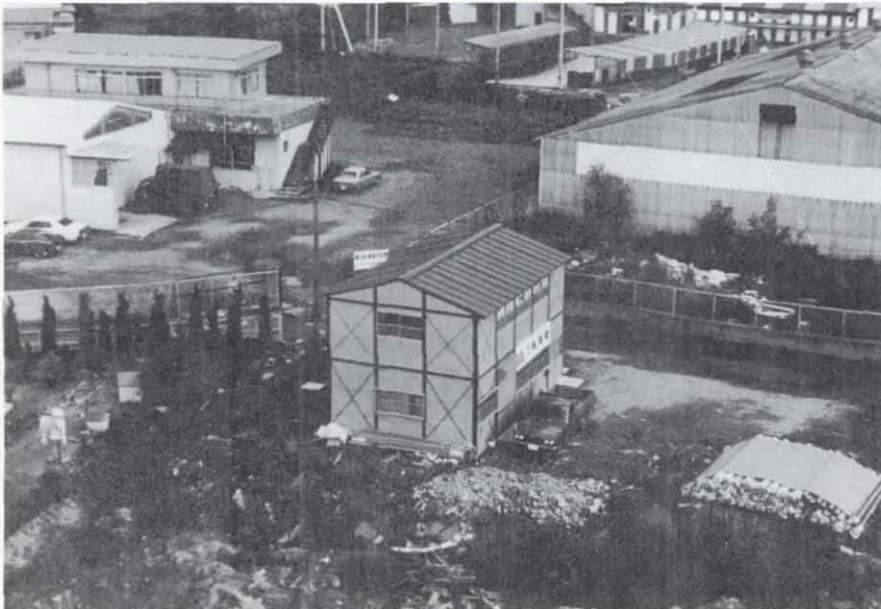

Figure 6.54 Concrete Batch Plant, Sendai: displacement due to damage to the light, unbraced steel superstructure damaged the vertical stack and the conveyor belt structure.

Figure 6.55 Concrete Batch Plant, Sendai: a typical undamaged light steel-framed structure braced with cable or rod braces.



7. EARTHQUAKE PERFORMANCE OF TRANSPORTATION LIFELINES*

7.1 INTRODUCTION

The Japanese Ministry of Construction (JMOC) reported that 78 highway bridges had been damaged as a result of the June 12, 1978, Miyagi-ken-oki earthquake. There were, however, no reports of damage to a multitude of pedestrian bridges in Miyagi prefecture. Only those bridges having an estimated repair cost of 1 million yen (\$5,000) or more were included in an inventory of damaged highway structures. Although damage to bridges was principally confined to those structures within Miyagi prefecture, some bridges sustained moderate damage in Iwate and Fukushima Prefectures also. Of approximately 100 bridges in Sendai, only four were reported as having been damaged. Two of those bridges were inspected by UJNR team members. The majority of damaged bridges were located in an area extending about 90 kilometers northeast of Sendai (see Table 5.1 and Figures 5.3 and 6.1).

The UJNR inspection team visited 13 highway bridge and four rail bridge sites, viewing representative damage. Typical types of damage included flexural and torsional cracking of concrete piers, displaced or dislodged girder bearing devices, settlements of abutments or piers, and vibratory induced settlements of fills at bridge approaches.

Significant strong motion records were obtained from the Kaihoku Bridge, 65 km northeast of Sendai and the Date Bridge about 75 km southwest of Sendai (just north of Fukushima City). Only the Kaihoku Bridge site was visited by UJNR team members. Maximum ground acceleration at Kaihoku was 294 gal, while maximum pier acceleration was greater than 500 gal. No ground record was obtained from the Date Bridge site. Maximum pier acceleration was 475 gal.

The Japanese National Railways stopped all trains following the earthquake until safety inspections could be made. Most damage was caused by blockage of track, by landsliding, and most train service was restored within 3 days following the earthquake. Heavy pier damage occurred at a rail bridge site which required 10 days to reopen.

There was no reported damage to highway tunnels in Miyagi prefecture. Only one railway tunnel on the New Sendai Shinkansen Line (fast train) northeast of Sendai was reported to have suffered minor, hairline cracks in its concrete lining.

The public bus system in Sendai was not adversely affected by the earthquake.

It is reported that airline traffic to and from Sendai was interrupted only briefly while a quick inspection of the airport was made by airport officials. Minor damage of the terminal was reported.

No major damage was reported at Shiogama Port 18 km northeast of Sendai. Some pavement settlement was noted. One free field strong motion record obtained from a SMAC B2 instrument at Shiogama Port recorded maximum accelerations of 266 gal in the N-S direction, 288 gal in the E-W direction, and 166 gal vertical component. For further discussion of strong motion records, see Chapter 4 of this report.

7.2 BRIDGE DESIGN CRITERIA

A comparison of current (1978) seismic bridge design criteria used in the United States and in Japan is presented prior to the documentation of bridge damage.

The bridges which were damaged in the June 12 earthquake in Japan were designed and constructed using pre-1971 design criteria. Most of the damaged bridges are two-lane structures, situated in rural areas northeast of Sendai. The most noticeable difference in the construction of bridges is the use of massive substructure elements. Most Japanese bridge piers are very large, massive appearing structures which are designed to resist seismic forces. Substructures in the United States are designed for lower seismic force levels and rely on ductile behavior of columns.

* Prepared by James D. Cooper, Federal Highway Administration Washington, D.C.

For purposes of comparing current U.S. and Japanese seismic design criteria the 1977 American Association of State Highway and Transportation Officials (AASHTO) and the 1971 Japan Road Association (JRA), "Specifications for the Earthquake-Resistant Design of Highway Bridges" are considered (see Refs. 7.1 and 7.2). The 1977 AASHTO criteria is an adaptation of the criteria developed by the California Department of Transportation in 1973. The 1971 JRA criteria superseded provisions found in several different Japanese bridge codes, and were established in order to give a common basis for the seismic design of bridges. They emphasize the method of evaluating seismic forces, the basic principles to be exercised for testing site soil conditions, and general provisions to be observed in structural detailing.

Both criteria allow for the use of three alternate approaches for determining design earthquake force levels. The most commonly used is the equivalent static force method. For more complex bridges, either a response spectrum analysis or full dynamic analysis can be performed. The more common, equivalent static force method used by both countries is compared.

Table 7.1 summarizes the 1977 AASHTO and 1971 JRA criteria.

The approach is similar in that the lateral force design coefficient is comprised of factors relating to location (A and $v_1 \cdot k_0$), soil conditions (S and v_2), and structure response (R/Z , F , and β). In addition, the JRA criteria incorporates an importance factor, v_3 . The vertical seismic force is generally not considered in either criteria, except in the JRA criteria for the design of bearings at the connection of the super and substructures. The vertical design seismic coefficient of $k_v = 0.1$ is used.

Use of either criteria requires the computation of the fundamental period of the bridge. The AASHTO criteria specifies the following formula to approximate the period (T) of the structure:

$$T = 0.32\sqrt{W/P}$$

which W is the dead load and P is the total uniform force required to cause a 1-inch maximum horizontal deflection of the total bridge. The JRA presents several alternate equations for use in estimating the period of the bridge which are dependent on the type of structural system, type of foundation, material of the pier, and direction of motion. The methods used to calculate period give slightly varying values which, when used in conjunction with a design spectra, give greatly varying values for design force levels.

For purposes of comparing the AASHTO and JRA criteria, the lateral force design coefficients are plotted in Figure 7.1. The comparison is made for a site having a depth of alluvium between 24 and 46 meters (80 and 150 feet), in a highly seismic area. For this condition, AASHTO requires $A = 0.5g$ and JRA requires $v_1 = 1.0$. Additionally, the JRA importance factor, v_3 , which is 1.0 for bridges on expressways, general national highways, and principal prefectural highways, etc., and 0.8 for all others, is assumed to be 1.0.

For the conditions assumed, the value of the JRA lateral force design coefficient (k_h) varies between 1.6 and 2.6 times the value given by the AASHTO criteria. The AASHTO criteria are applicable to structures having a period less than or equal to 3 seconds while the JRA criteria are applicable to structures having a natural period less than 5 seconds. The discontinuity of k_h at $T = 0.5$ is due to the increase of the modification factor (β) to reflect structural dynamic response and ground conditions. The larger JRA lateral force design coefficients would thus require the use of large substructure designs to resist earthquake forces when compared to designs using AASHTO criteria.

Seismic design criteria for highway bridges are currently (1979) under review by both the Japanese Ministry of Construction and the Federal Highway Administration. Both countries are in the process of revising requirements for determining seismic design force levels and structural details to provide improved resistance to earthquake induced ground motion.

7.3 BRIDGE DAMAGE

Significant bridge damage occurred during the June 12 earthquake. Given, however, the magnitude of the earthquake and the fact that most bridges damaged were pre-1960 vintage,

TABLE 7.1

Equivalent Static Force Method Code Comparison

Criteria	1975 AASHTO	1971 JRA
Lateral Force (EQ)	CFW	$k_h W$
Lateral Force Design Coefficient	$C = \frac{ARS}{Z}$ <p>Graphs of C as a function of bridge period and depth of alluvium are given where:</p> <p>A = max. expected to bedrock acceleration and related to 3 U.B.C. seismic zones.</p> <p>R = normalized rock response as a function of bridge period.</p> <p>S = soil amplification spectral ratio as a function of bridge period.</p> <p>Z = reduction factor for ductility and risk.</p>	$k_h = (v_1 v_2 v_3 k_0)^\beta$ $k = 0.2$ <p>β is a modification factor used when the bridge period is > 0.5 sec. and is a function of period and ground condition; where:</p> <p>v_1 = seismic zone factor.</p> <p>v_2 = soil factor based on depth of alluvium.</p> <p>v_3 = importance factor based on qualitative definition.</p> <p>k_0 = standard horizontal design seismic coefficient = 0.2.</p> <p>β = modification factor as a function of bridge period when period > 0.5 sec.</p>
Framing Factor	<p>F = 1.0 for single columns.</p> <p>F = 0.8 for continuous frames.</p>	None
Vertical Force Design Coeff.	None	$k_v = 0.1$ for design of bearing between sub and superstructure.
Design Force for Seismic Earth Pressure	No	Yes
Hydrodynamic Pressure During Earthquake	No	Yes

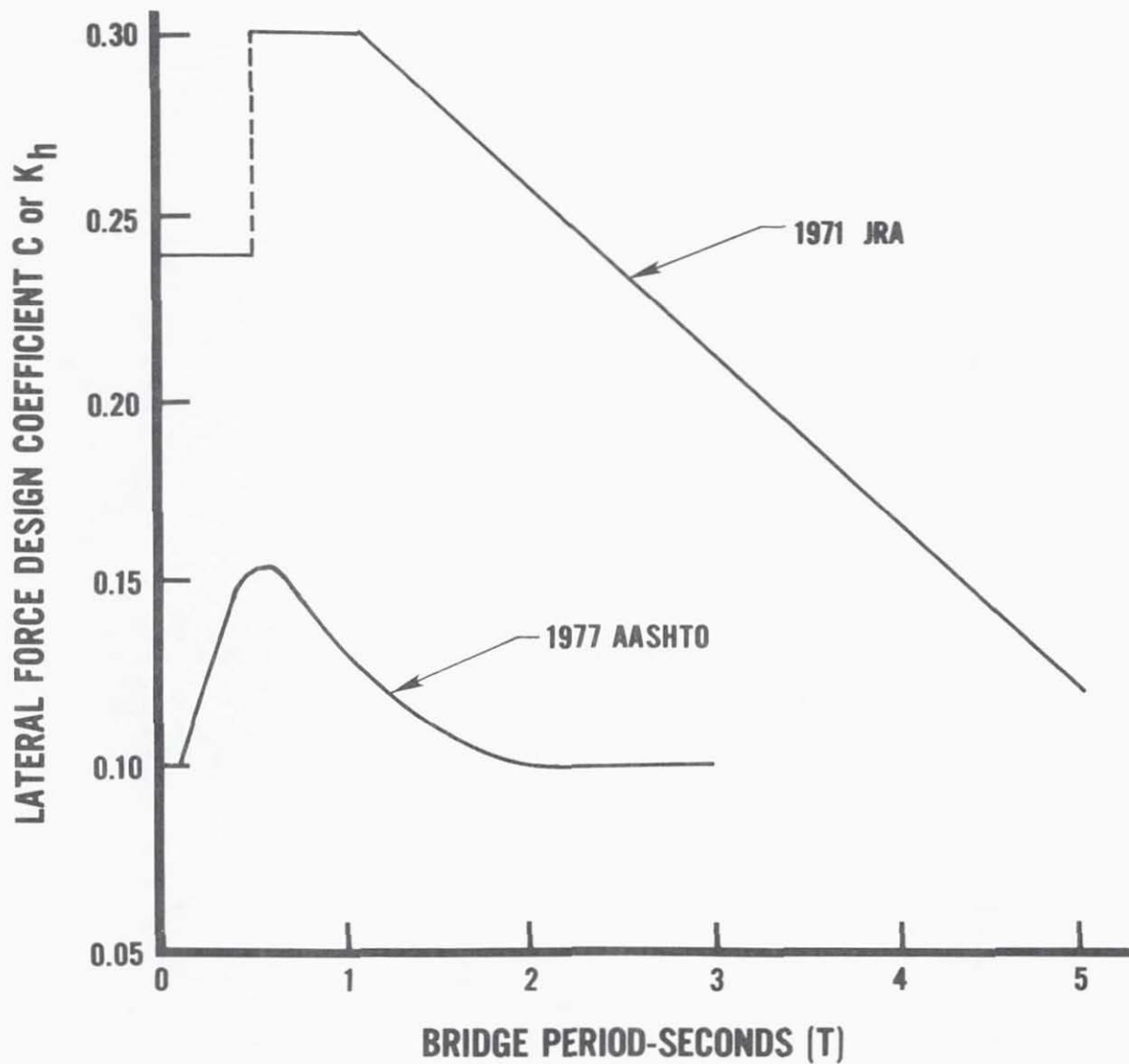

Figure 7.1 Comparison of AASHTO and JRA Lateral Force Design Coefficients

some dating back to 1930, bridges performed relatively well. The area of bridges affected extended from 20 km south of Sendai to 90 km northeast of Sendai. Refer to Figure 6.1 for location of bridges discussed. Table 7.2 summarizes the performance of those bridges inspected following the earthquake.

The UJNR inspection team arrived in Japan 10 days following the earthquake. The response plan to repair damage and open bridges incorporated by the Japanese Government was most impressive. Three bridges in or near Sendai which suffered major pier damage were in the process of being repaired and open to traffic. Other bridges in outlying areas were either in various stages of repair or plans were being made to build replacement structures. Following is a description of damage to those visited by the UJNR inspection team.

Kin-noh Bridge

The Kin-noh Bridge, (Figures 7.2 - 7.10) located about 65 km northeast of Sendai on National Highway, Route 346, is a two-lane, 15 span multi-configuration structure that is 575 meters long. The structure was constructed in 1956 and is comprised of nine simply supported plate girder spans, each 28 m in length; four of the spans are totally suspended; five are simply supported through-truss spans, each 60 m in length; and one is a simply supported plate girder span, 23 m in length. Three major earthquakes have occurred in the region since construction of the Kin-noh Bridge: (1) in 1962 (2) on February 20, 1978, in which significant damage occurred at one of the abutments and to the bearing devices; and (3) the current earthquake in which one of the suspended spans dropped. Repair work from the February 20 earthquake was underway at the time of the June 12 earthquake and had included the replacement of bearings on the five truss spans and tying the truss spans together with restrainers. The abutment at the end of the nine plate girder spans had been shored, but not repaired. Miyagi Prefecture has proposed replacing the bridge at an estimated cost of 16 million dollars (3.2 billion yen).

Yuriage Bridge

The 10-span Yuriage Bridge (Figures 7.11 - 7.18), constructed in 1962, is located 1.2 km from the mouth of the Natori River on the outskirts of Sendai and is 107 km from the epicenter. It has seven prestressed concrete T-girders each 45 m in length and three main spans which are twin cell, segmentally constructed, post-tensioned concrete box girders, 60, 90, 60 meters in length. The bridge was open to one lane of traffic because of heavy column damage. No damage was reported to the three-span box structure. Excavation at the first pier at the opposite side of the bridge was being done to determine the extent, if any, of foundation damage.

Sendai Ohashi Bridge

The Sendai Ohashi Bridge over the Hirose River on Japan National Highway, Route 4, constructed in 1965, suffered heavy pier damage (Figures 7.19 - 7.27). The structure is a nine-span, simply supported composite concrete and steel plate girder bridge with 34 m span lengths. The bridge had been retrofitted at points across the joints at the piers with steel restraining plates bolted to the girder webs. The bridge was closed to traffic the night of June 12 while temporary pier supports were constructed at two of the more severely damaged piers.

Although the UJNR team inspected the bridge site only 11 days after the earthquake, repair efforts were well underway, making it impossible to view much of the original damage.

Abukuma Bridge

The Abukuma Bridge (Figure 7.28), located about 20 km south of Sendai on National Highway, Route 6, near the junction of Route 4, is a two-lane, 17-span structure 571 meters long. The structure is comprised of eight plate girder approach spans, each 18 m in length, seven through truss-spans, each 55 m in length, which cross the Abukuma River, and two 18 m plate girder spans. Significant damage occurred to the portal frame piers which were being repaired at the time of the inspection (Figures 7.29 and 7.30).

TABLE 7.2
Summary of Highway Bridges Inspected

Name	Map Location No. from Fig. 6.1	Type	Main Damage
Kin-noh	35	Steel Plate Girder, Through Truss	Down-in span dropped out, bearings dislodged.
Yuriage	22	Prestressed Concrete I-Girders and Concrete Box Girder	Massive pier cracking, bearing dislodgment; pier settlement, abutment cracking.
Sendai	37	Steel Plate Girder	Massive pier cracking footing damage, bearings dislodged, abutment damage.
Abukuma	23	Steel Plate Girder	Pier cracking.
Kaihoku	29	Steel Box Girder	None. Settlement of roadway at abutment.
Tenno	30	Steel Plate Girder and Tied Arch	Pier cracking.
Kitakami	36	Steel Deck Truss	None. Apron settlement at abutment.
Kimazuka	27	Steel Plate Girder	Bearing dislodgement; possible pier tilting.
Maiya	34	Steel Gerber Truss	Brittle fracture of top chord member and buckling of top lateral truss bracing.
Toyoma	33	Concrete T-Beam	Flexural cracking of T-beams and shear crack- ing of hinge seats; abutment cracking.
Ono	26	Steel Plate Girder	Abutment damage, bearing damage, and possible pier tilting.
Iinogawa	31	Steel Box Girder	Bearing dislodged.
Yanaizu	32	Steel Deck Truss	Abutment settlement and bearing damage.

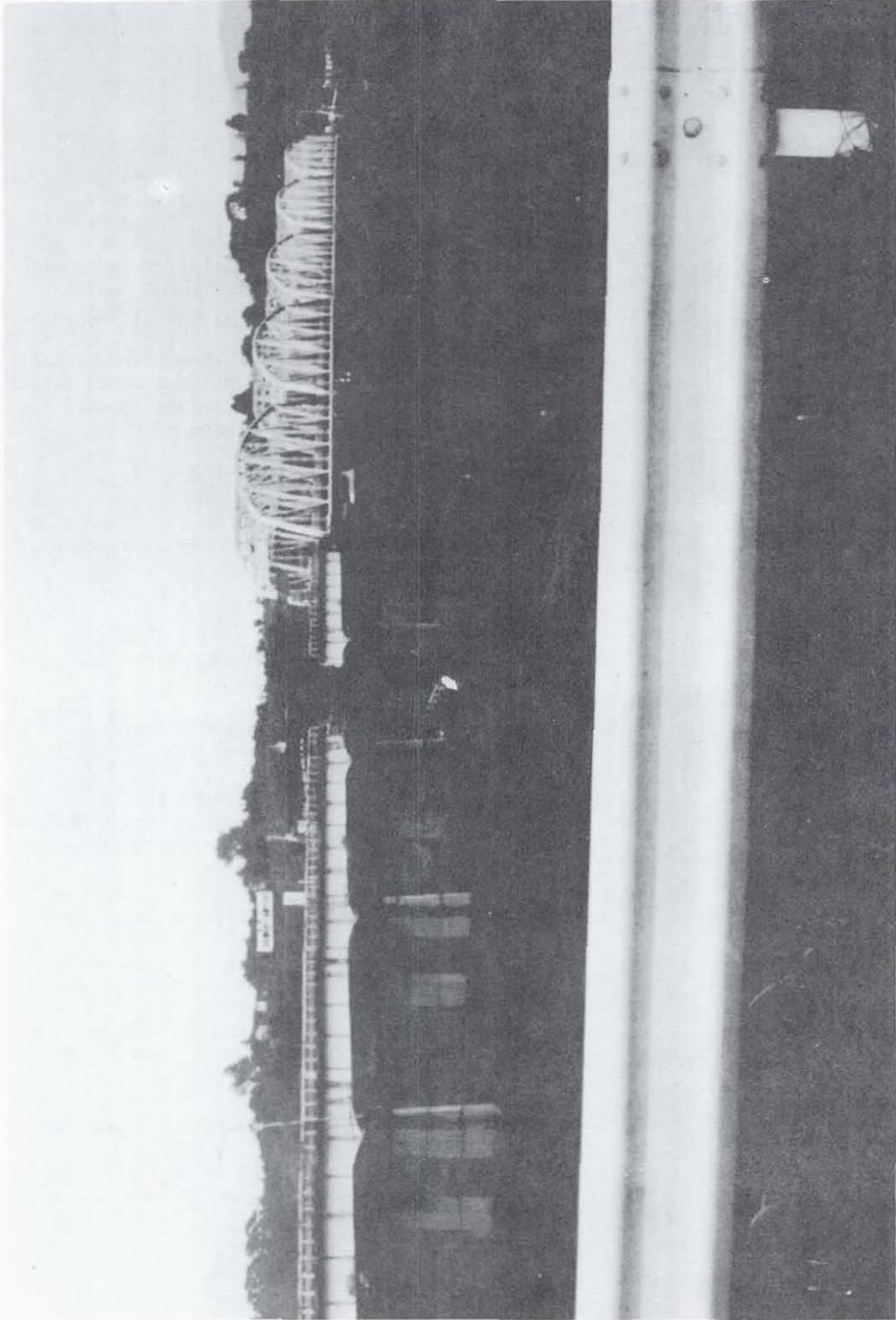

Figure 7.2 General view of the Kin-noh Bridge

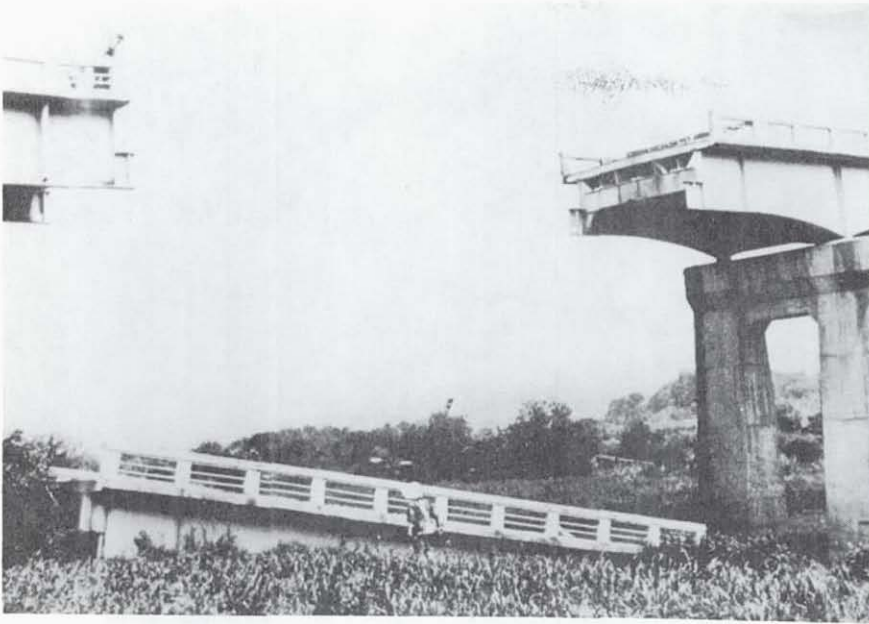

Figure 7.3 Kin-noh Bridge. View of the collapsed suspended plate girder span. Similar damage occurred to bridges in the 1971 San Fernando and 1976 Guatemala earthquakes because of lack of superstructure restraint and small bearing seats. Suspended spans are no longer used in seismically active areas. (Courtesy J.M.O.C.)

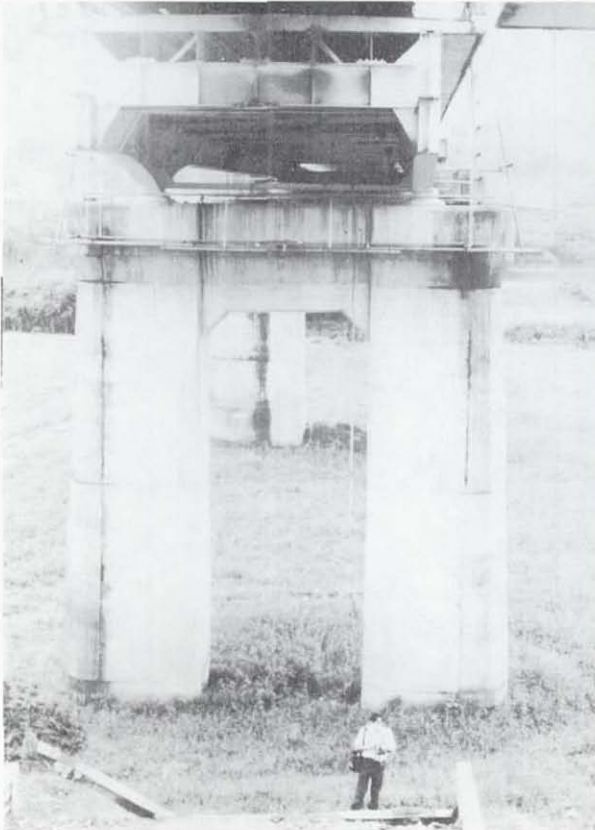

Figure 7.4 Kin-noh Bridge. The only visible pier damage occurred at Pier 8, which is adjacent to the collapsed suspended span. Shear cracking extended 125 cm through the 152 cm deep pier, approximately one-fourth the way up the column from grade.

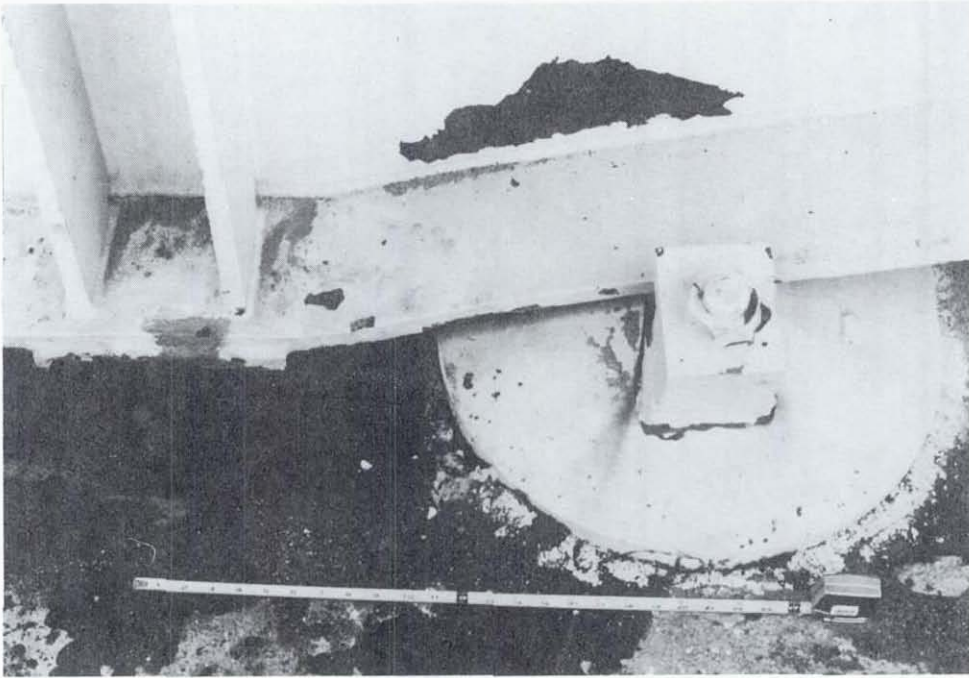
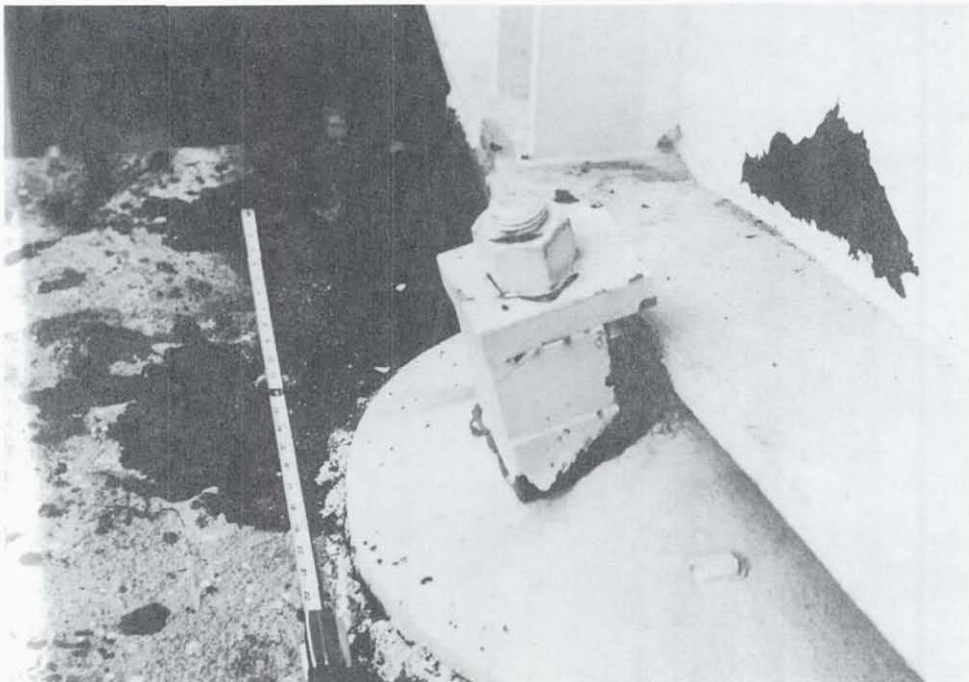

Figure 7.5 Kin-noh Bridge. The girders at Pier 8 displaced longitudinally toward the abutment 55 cm allowing the unrestrained suspended span to drop off the 45 cm hinge seat. The movable girder bearing plate came to rest at the edge of the pier cap. The fixed bearing on Pier 7, the opposite side of the suspended span, displaced longitudinally 0.5 cm.

Figure 7.6 Kin-noh Bridge. Evidence of minor transverse displacement of the main girder with broken keeper. This reportedly occurred at the time of the February 20 earthquake.



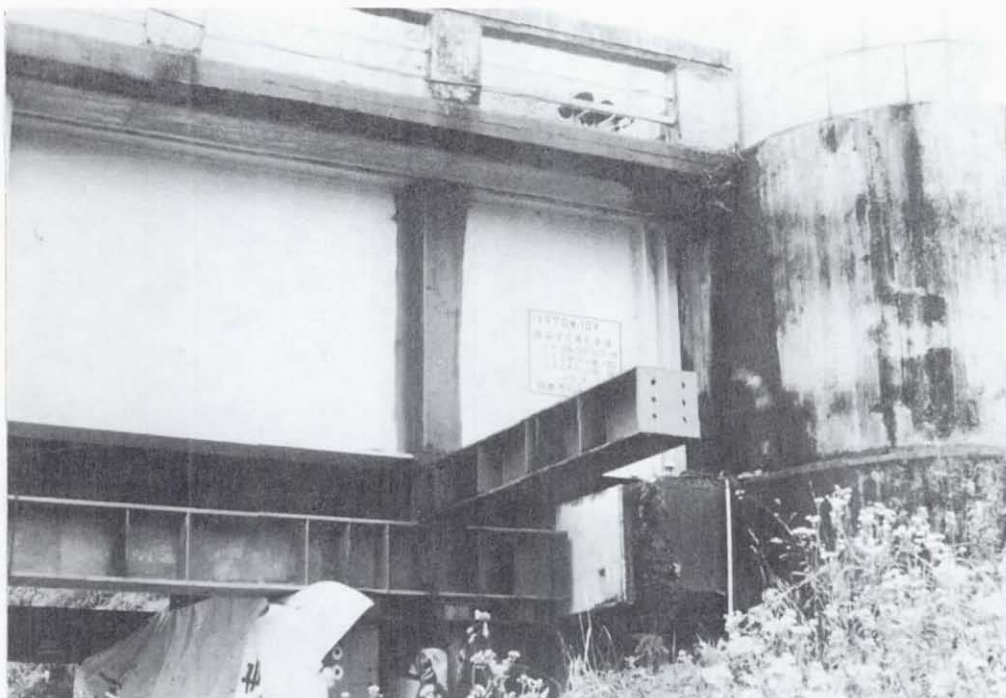

Figure 7.7 Kin-noh Bridge. Damaged abutment from the February 20, 1978, 6.7 magnitude earthquake. New web stiffener at point of temporary shoring.

Figure 7.8 Kin-noh Bridge. Detail of bearing damage and abutment ledge failure, from February earthquake. Note extension of anchor bolt caused by 20 cm displacement of span towards abutment.



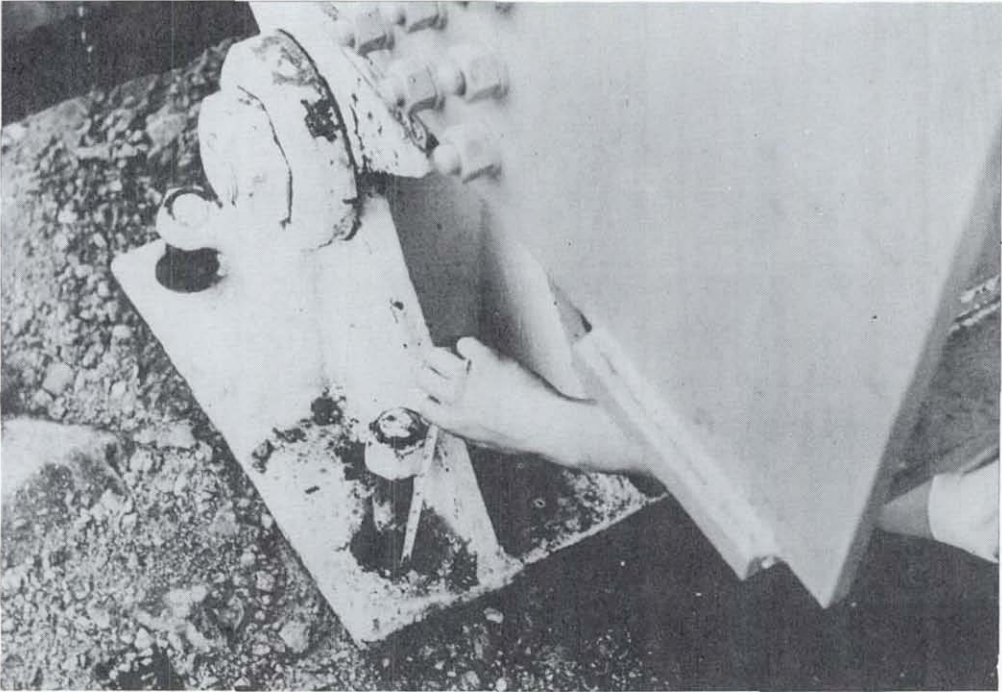

Figure 7.9 Kin-noh Bridge. Extension of anchor bolts at Pier 6. The foreground shows a portion of repaired lower chord truss member.

Figure 7.10 Kin-noh Bridge. Bearing restraining device used on the repaired bearing supports of the truss spans. The restrainers were placed before the June 12 event.



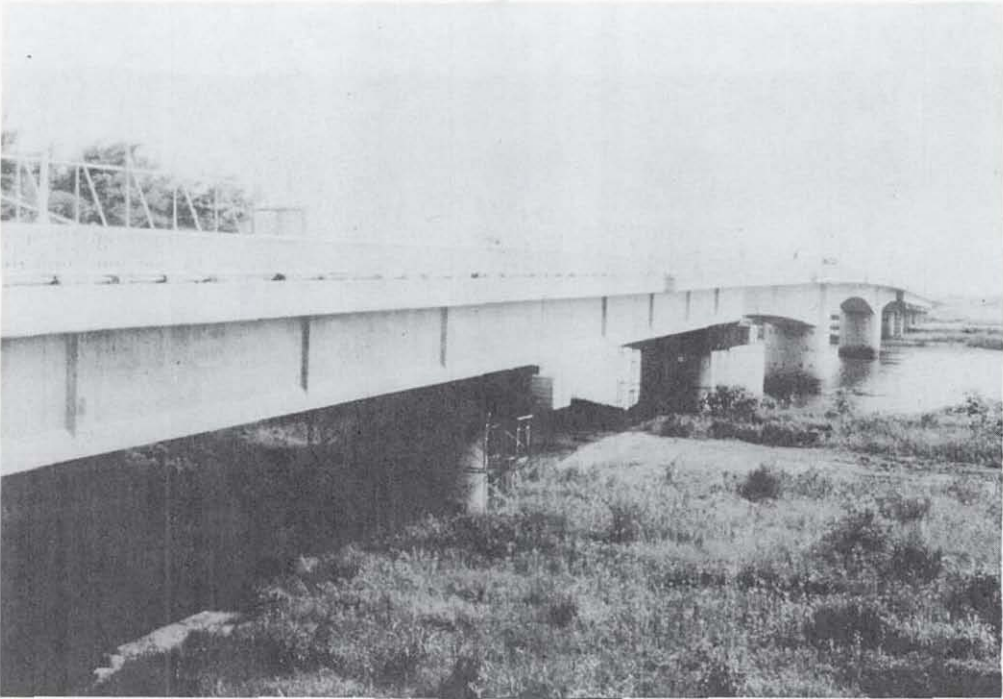

Figure 7.11 General view of the Yuriage Bridge showing the first two columns which were heavily damaged.

Figure 7.12 Yuriage Bridge. Liquefaction in the flood plan below the bridge.



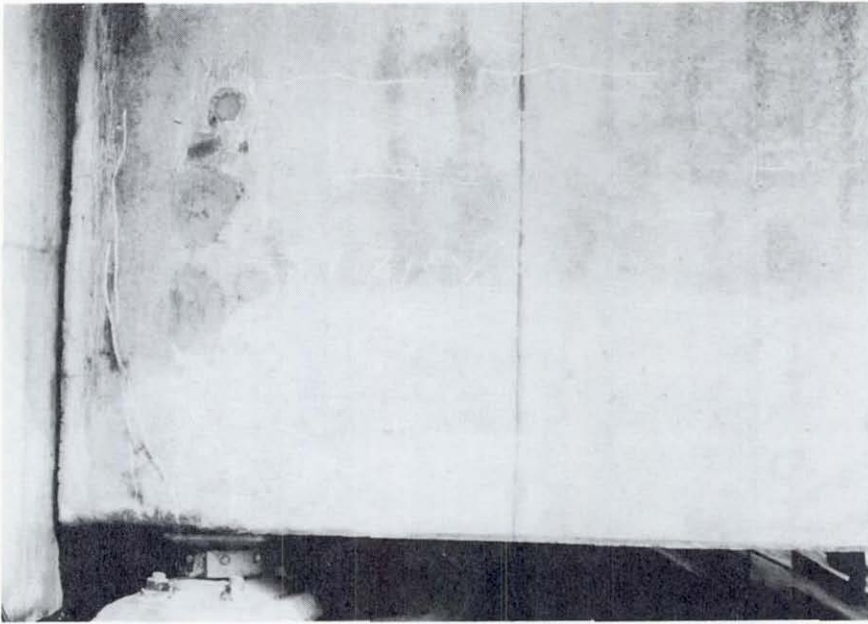

Figure 7.13 Yuriage Bridge. Evidence of light girder impacting with the abutment and pronounced shear cracking of exterior girder at the bearing.



Figure 7.14 Yuriage Bridge. Pier 1, founded on a caisson 19 m deep and 2 m by 4 m in plan, suffered heavy shear cracking. The pier cap was reported to have settled uniformly 5 cm.

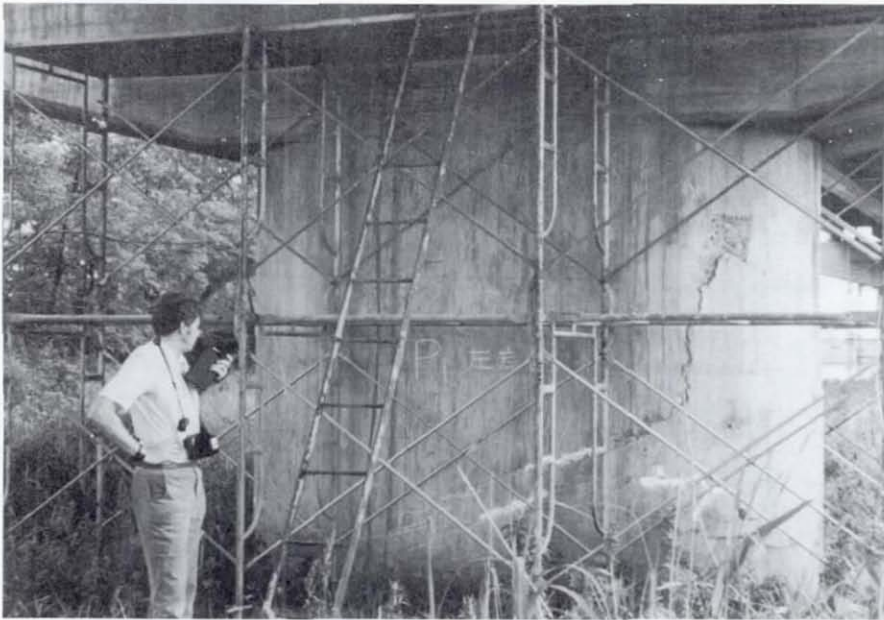

Figure 7.15 Yuriage Bridge. The face of Pier 1 showing severe distress. The plaster of paris patchwork is used to determine if additional pier cracking has occurred.



Figure 7.16 Yuriage Bridge. Detail showing 1 cm offset of cracking, indicating torsion in pier.

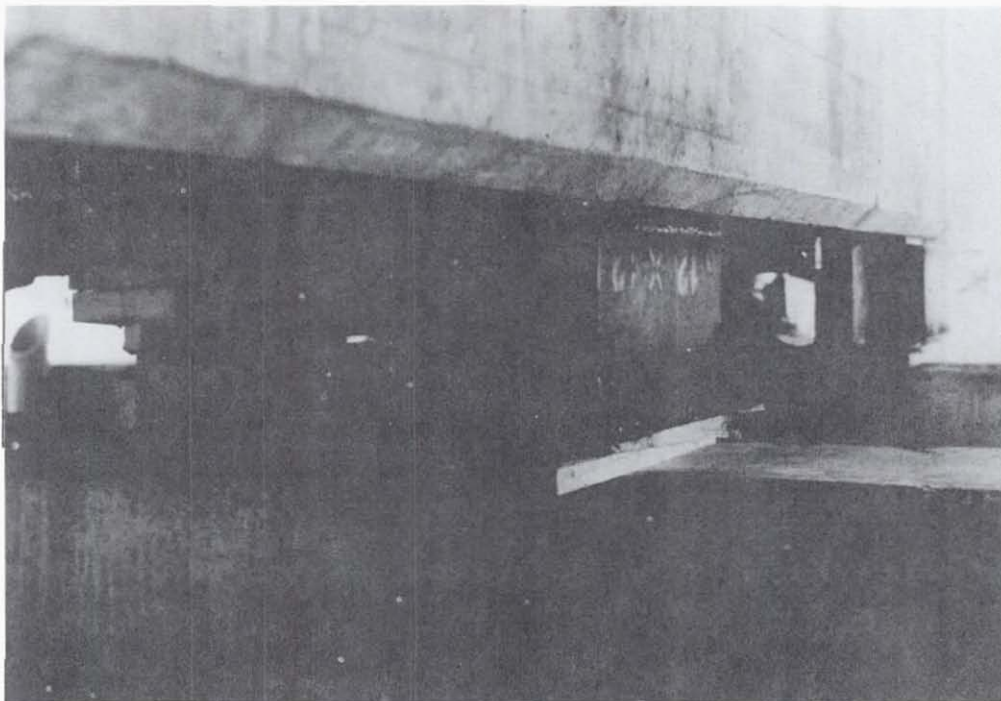

Figure 7.17 Yuriage Bridge. Temporary girder supports at Pier 1. Bearings showed evidence of girder displacement - broken keeper and containment plates.

Figure 7.18 Yuriage Bridge. Evidence of 8 cm of longitudinal movement as shown at the handrail expansion joint, Pier 2. However, there was no evidence of damage to the girders or the second pier.

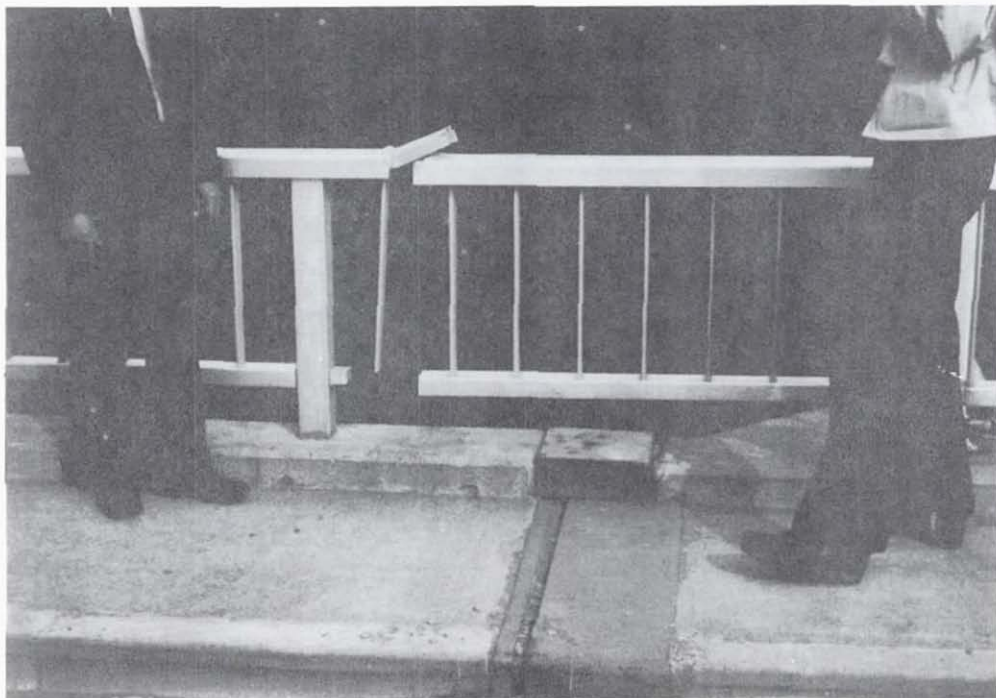
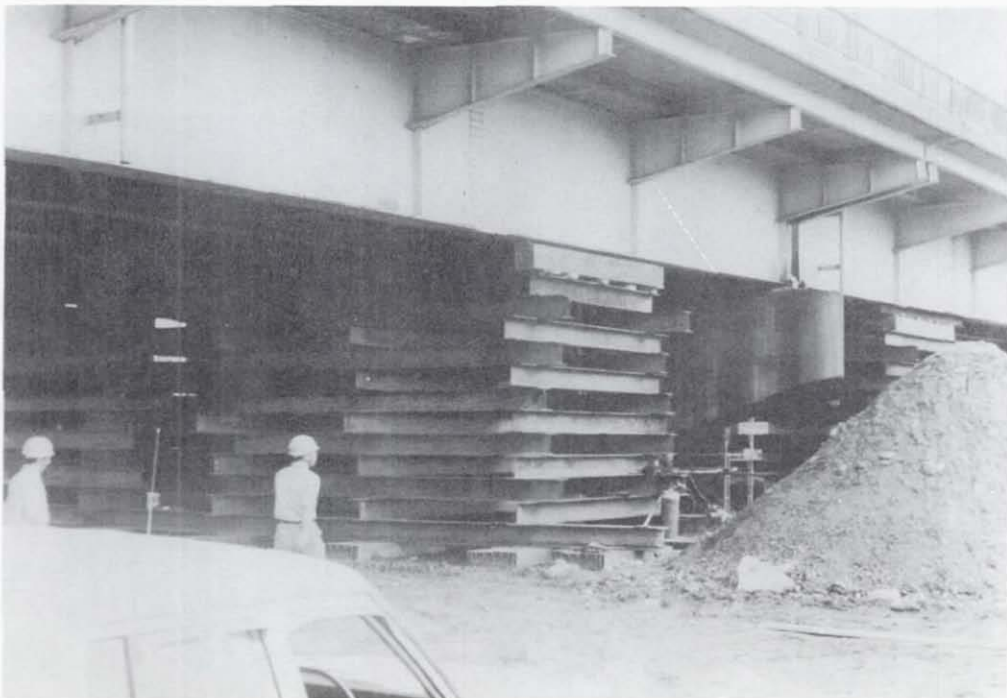



Figure 7.19 General view of the Sendai Ohashi Bridge. The deck arch bridge in the background, which is comprised of two steel plate girders with cross bracing and supported on slender circular columns, carries an industrial water pipeline and was reportedly undamaged.

Figure 7.20 Sendai Ohashi Bridge. Temporary cribbing used to support the steel plate girders.



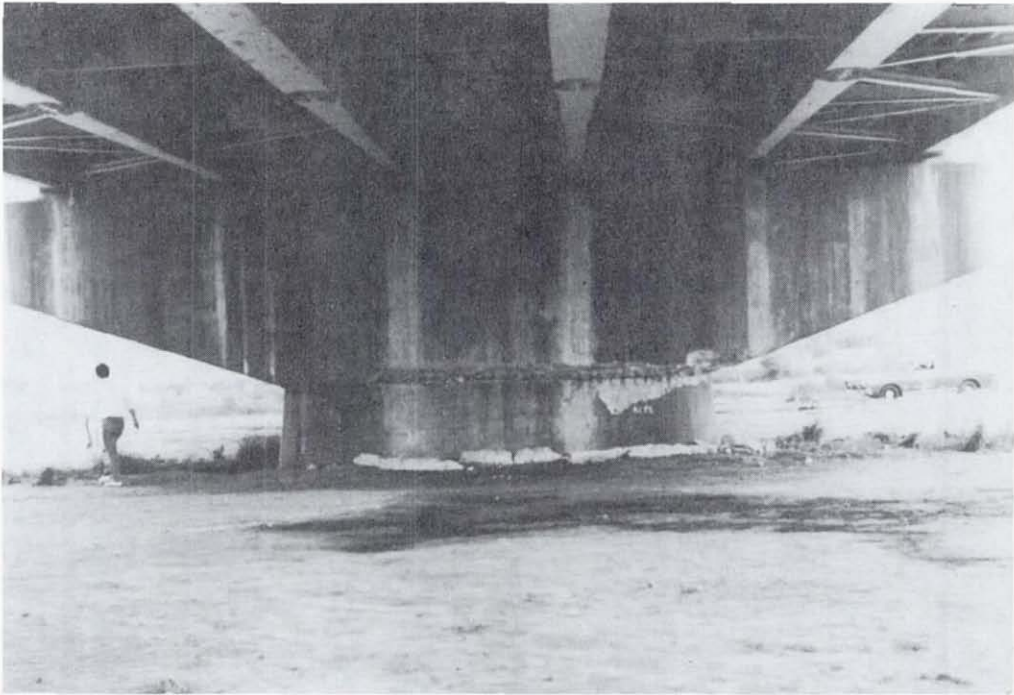
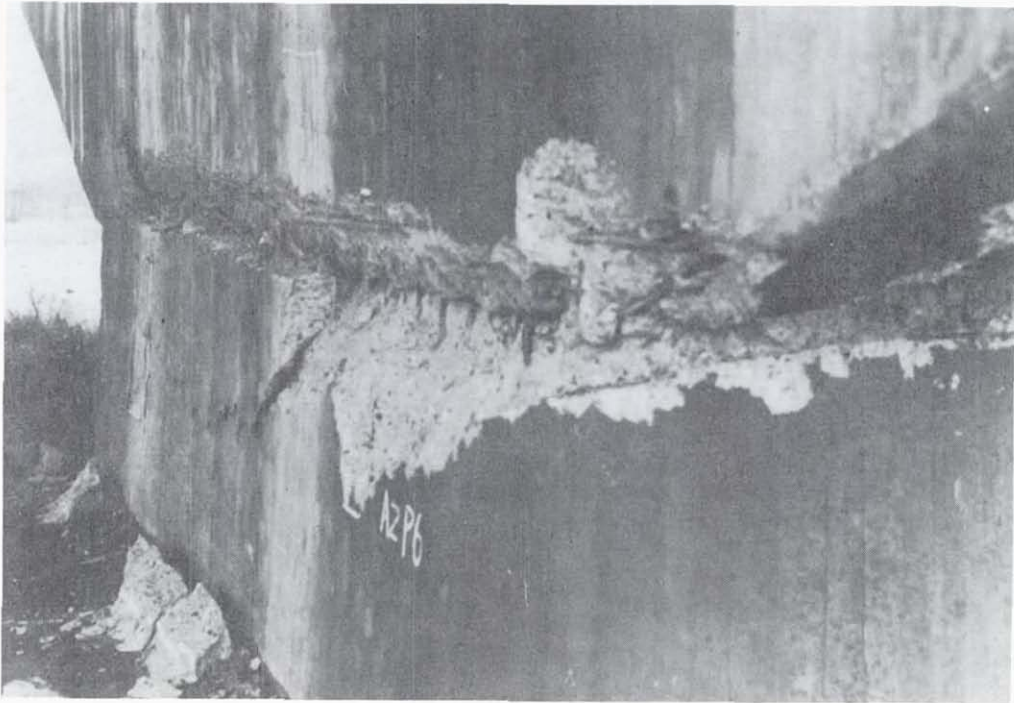

Figure 7.21 Sendai Ohashi Bridge. Typical pier configuration. The cross pier dimensions are approximately 5 m x 2 m. Note the massive pier caps. (Courtesy J.M.O.C.)

Figure 7.22 Sendai Ohashi Bridge. Typical pier damage at the construction joint between pier and cap. The vertical rebar are buckled across the joint. Significant concrete spalling is evident. Horizontal cracking around the pier was discovered upon excavation of soil around the piers. (Courtesy J.M.O.C.)



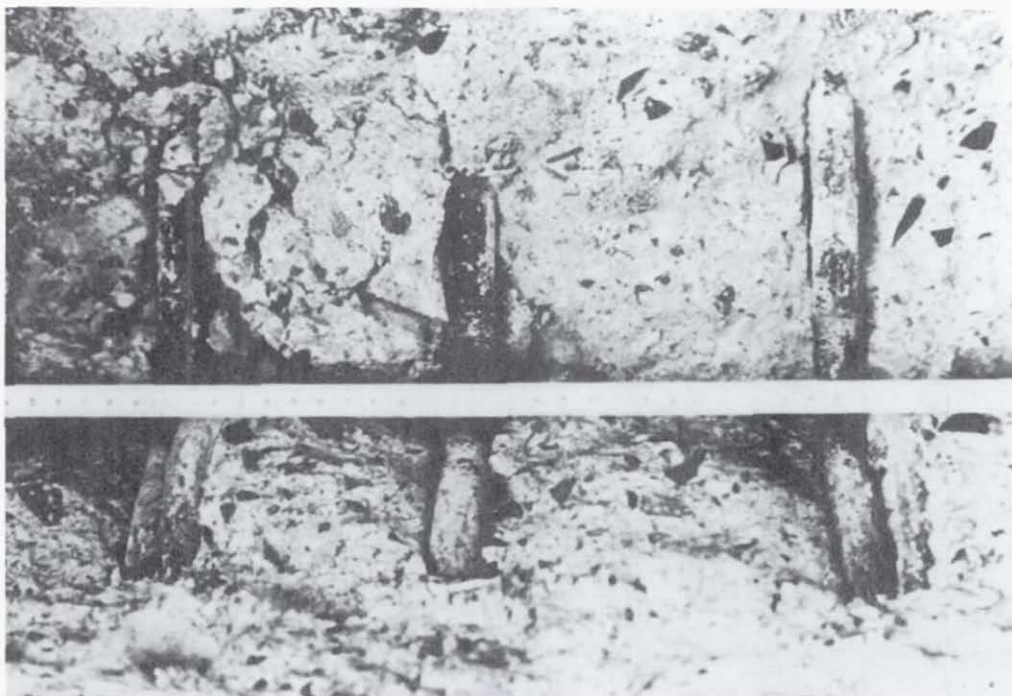

Figure 7.23 Sendai Ohashi Bridge. Detail showing buckled vertical rebar at the construction joint. Strong motion records in Sendai indicated approximately 100 gal. vertical accelerations. (Courtesy J.M.O.C.)

Figure 7.24 Sendai Ohashi Bridge. Typical damage to the base of a pier before repair.



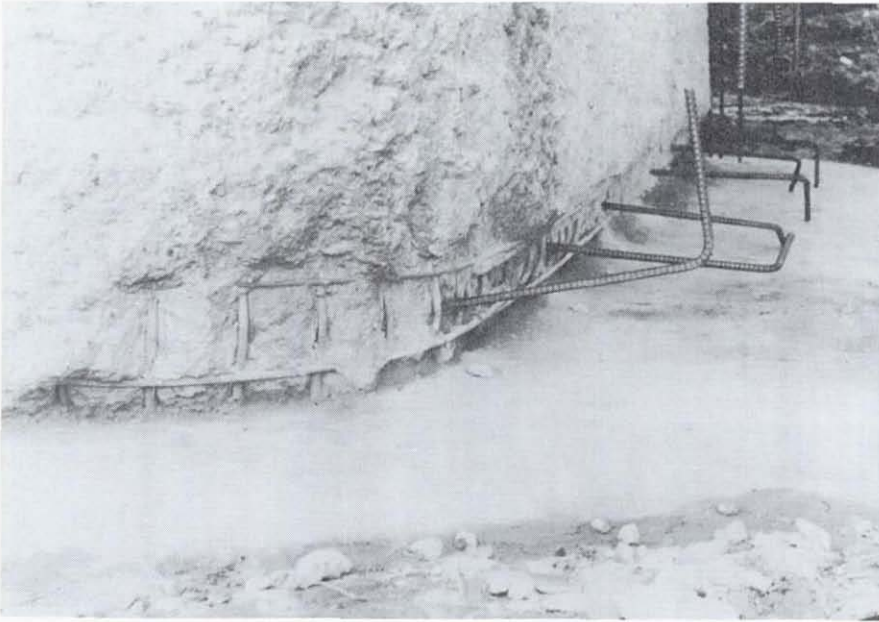

Figure 7.25 Sendai Ohashi Bridge. Typical damage being repaired at the base of the pier. Note the outward buckling of the underformed vertical rebar. The concrete cover had been roughened, the footing strengthened, and additional rebar placed to strengthen the pier.

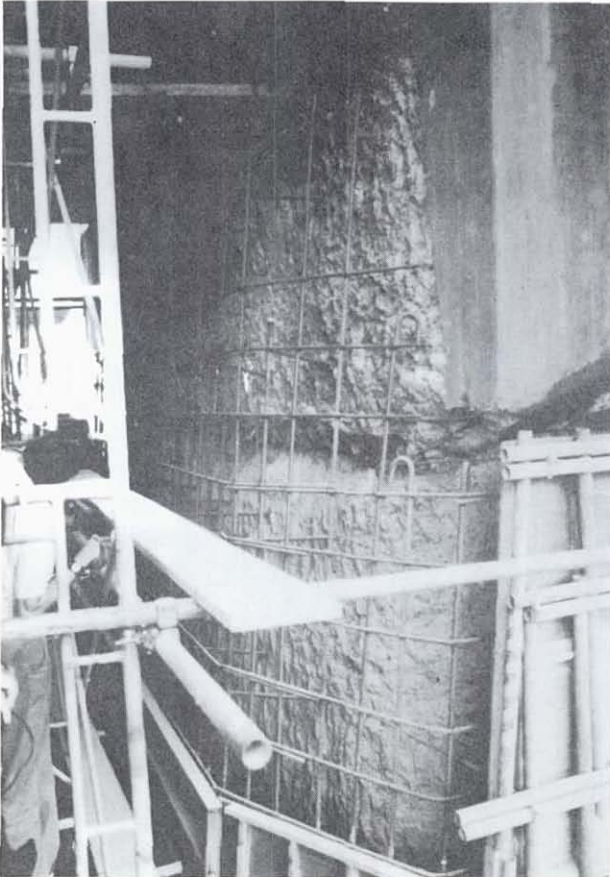

Figure 7.26 Sendai Ohashi Bridge. Details showing the added reinforcing concrete form work. The pier thickness will be increased on each side by 50 cm at the top, tapering to 70 cm at the base.

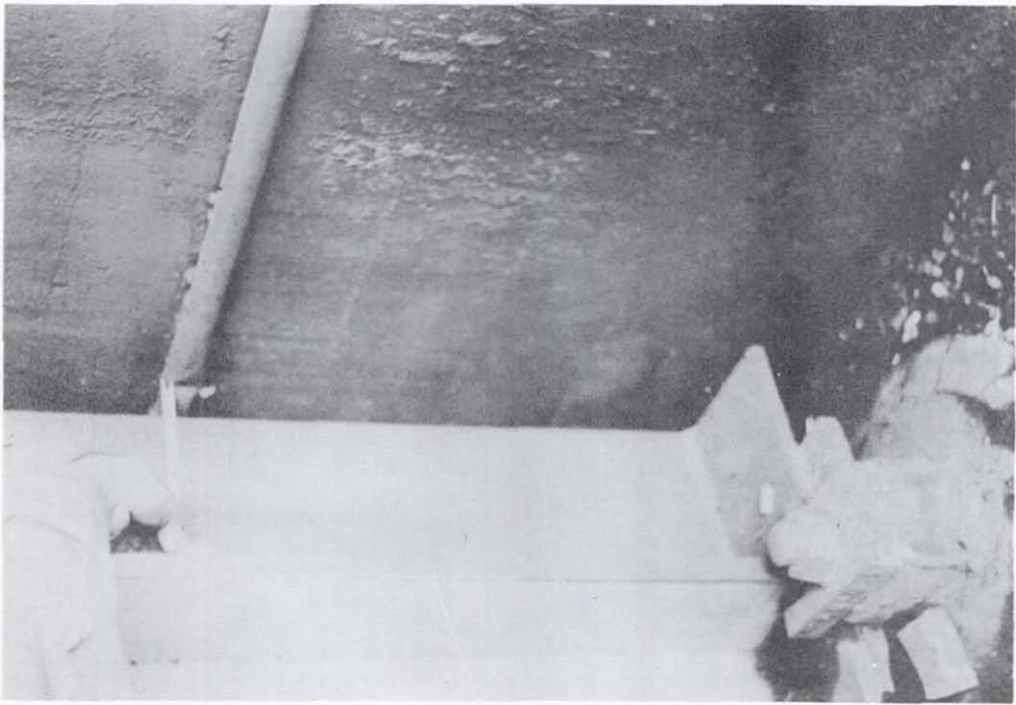

Figure 7.27 Sendai Ohashi Bridge. Abutment damage. Bearing plate broken and evidence of girder impact at abutment.

Figure 7.28 General view of the Abukuma Bridge. Note the trace of pier cracking on the pier in the foreground and scaffolding at and surface preparation of the pier in the background.



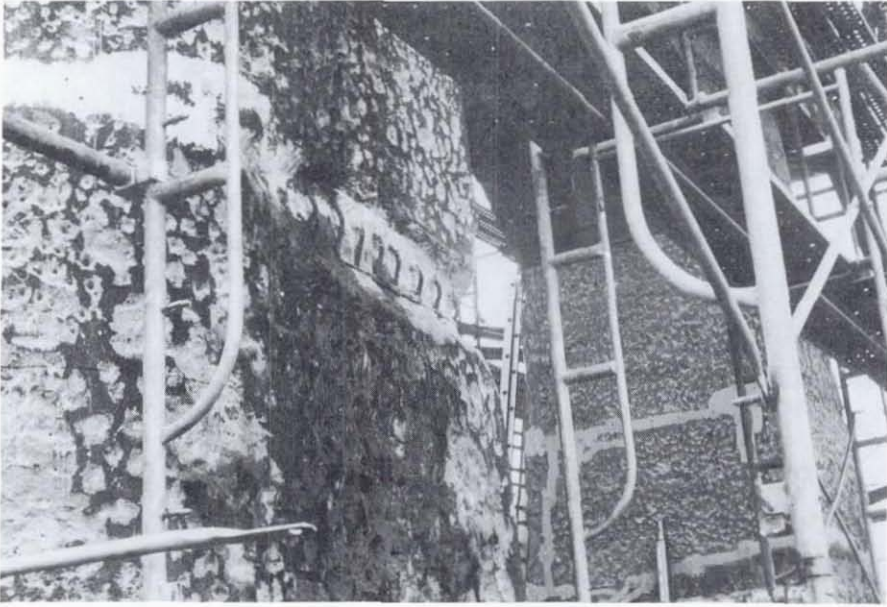

Figure 7.29 Abukuma Bridge. Outward buckling of vertical rebar at one of the damaged piers.

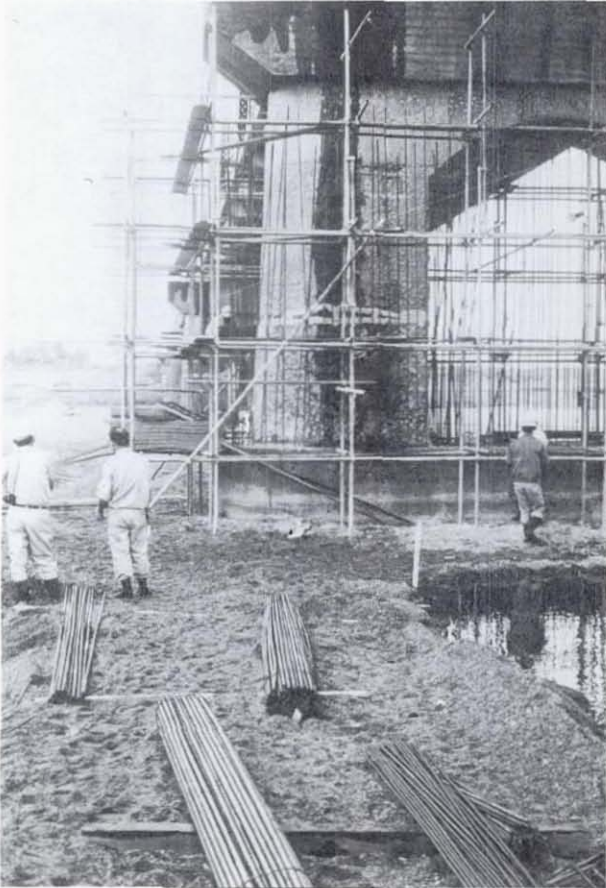

Figure 7.30 Abukuma Bridge. Typical repair of a damaged pier includes epoxy injection of cracks, epoxy covering of buckled rebar, preparation of existing concrete surface to accept fresh concrete, emplacement of vertical rebar into the footing and horizontal rebar into the pier, and an increase of the gross cross sectional area of the pier with new concrete. The technique is similar to that used on the Yuriage and Sendai Ohashi bridges.

Kaihoku Bridge

The Kaihoku Bridge, located on Principal Route 51, approximately 45 km northeast of Sendai, is a two-lane, five-span continuous single cell steel box girder, 285 m in total length (Figure 7.31).

The bearings are movable at all piers except Pier 2, Figures 7.32, where a SMAC-B type strong motion accelerograph is located. Hydraulic dampers acting in the longitudinal direction have been incorporated into the bearing system. All piers and the abutments are skewed. A free field SMAC-B instrument was located on rock between Pier 1 and Pier 2, approximately 30 meters from the structure. The axes of the pier and free field instruments were aligned with principal axes of the bridge. The peak recorded accelerations are:

	<u>Longitudinal</u>	<u>Vertical</u>	<u>Transverse</u>
Free Field	200 gal	113 gal	294 gal
Pier	500 gal or more (off scale)	138 gal	338 gal

The only damage noted was minor settlement of an abutment wing wall. Closer inspection by the Japanese revealed detachment of mortar near anchor bolts of the dampers. There was not visible damage to the piers or bearings, and no evidence of girder impacting with the east abutment.

Tenno Bridge

The Tenno Bridge, Figure 7.33, located approximately 50 km northeast of Sendai on National Route 45, is comprised of several steel plate girder approach spans with a tied arch main span. The total bridge length is 367 meters. The only damage occurred at the southwest wall pier where a 45° crack extended from the pier cap to a point one-third the way down the pier. Traffic was limited to one lane at the damaged pier.

Kitamami Ohashi Bridge and Dike

The seven-span, 400 m Kitakami Ohashi Deck Truss Bridge, completed in 1976, crosses the Kitakami River, 60 km northeast of Sendai on Principal Route 23 (Figure 7.34). The structure suffered no visible structure damage although there was minor settlement of the abutment apron. The structure was designed with the latest Japanese criteria and incorporated new abutment bearing details (Figure 7.35). Significant damage occurred to the dike and roadway along the Kitakami River south of the bridge site, (Figure 7.36). The most severe damage occurred along the approximately one-half kilometer length in which the roadway on top of the dike settled about 1.5 m. The roadway was closed to traffic, the dike sand-bagged, and continuous steel sheet piling was being driven to stabilize the dike.

Kimazuka Bridge

The Kimazuka Bridge, constructed in 1931, is located on Principal Route 32, approximately 35 km northeast of Sendai (Figure 7.37). It is a 19-span, simple supported, steel plate girder structure 236 m in length. Damage occurred to the top of the piers where bearing shoes pulled out of the top of the portal frame (Figures 7.38, 7.39). Longitudinal movement of the girders almost exceeded the bearing area of the bent cap. Sand boils and ground cracking were noted at the bridge site.

Maiya Ohashi Bridge

The Maiya Ohashi Bridge, Figure 7.40, is a three-span Gerber-truss bridge located on National Highway Route 342 approximately 62 km northeast of Sendai. The 181 meter long truss bridge, constructed in 1928, was closed to traffic because of a brittle fracture through the rivet holes of the top chord channel members at the first pier, Figure 7.41. Four steel plates had been welded around the top chord members. Some of the small steel angle top lateral bracing members were buckled in the vicinity of the pier, Figure 7.42. No damage was reported to either of the piers or abutments. The Maiya Bridge is scheduled to be replaced.

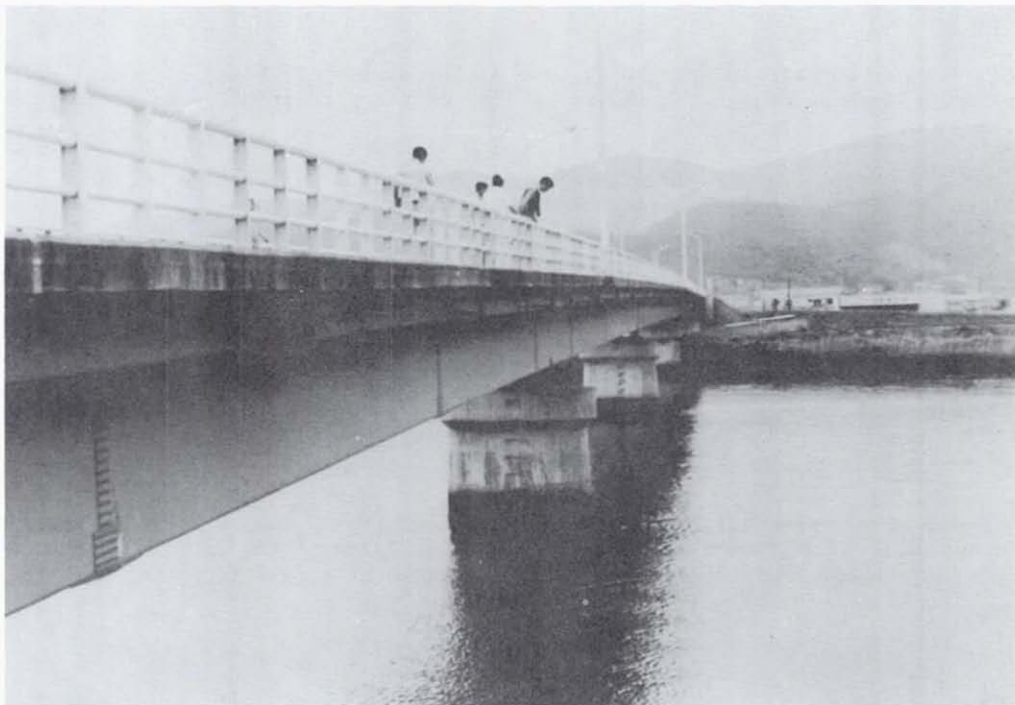
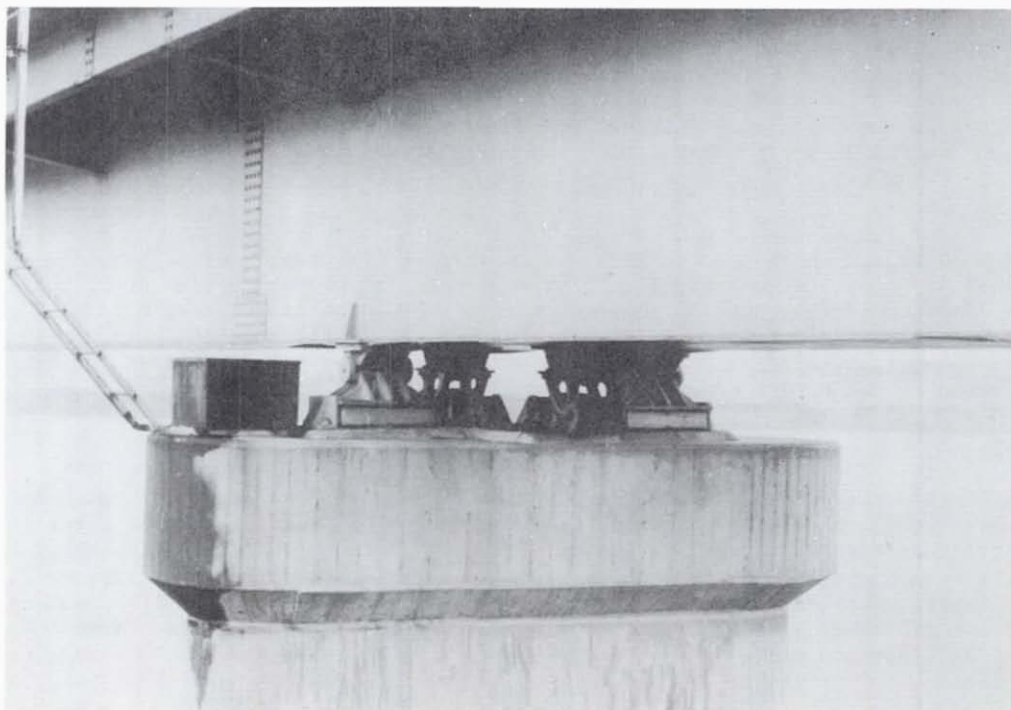

Figure 7.31 General view of the Kaihoku Bridge. (Courtesy J.M.O.C.)

Figure 7.32 Kaihoku Bridge. Pier 2 showing the SMAC-B2 instrument (which recorded a peak acceleration greater than 500 gal. in the longitudinal direction) and the fixed bearing and hydraulic damper system.



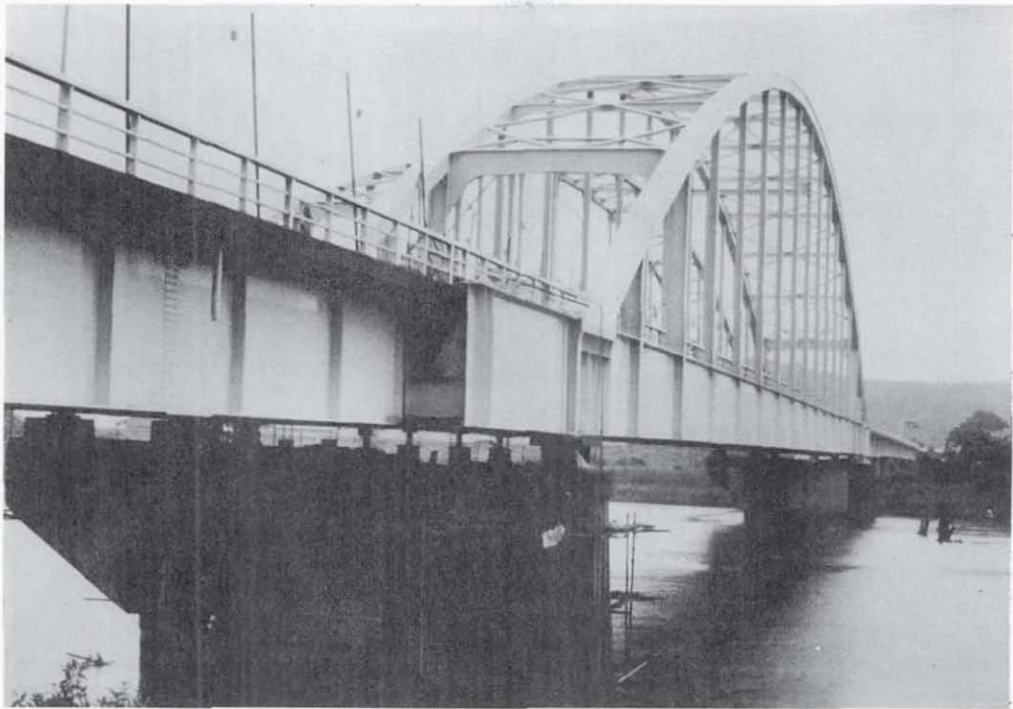

Figure 7.33 The main tied arch span of the Tenno Bridge with the cracked wall pier in the foreground. Note the smaller, pedestrian bridge in the background.

Figure 7.34 Kitakami Ohashi Bridge. No structural damage was reported.



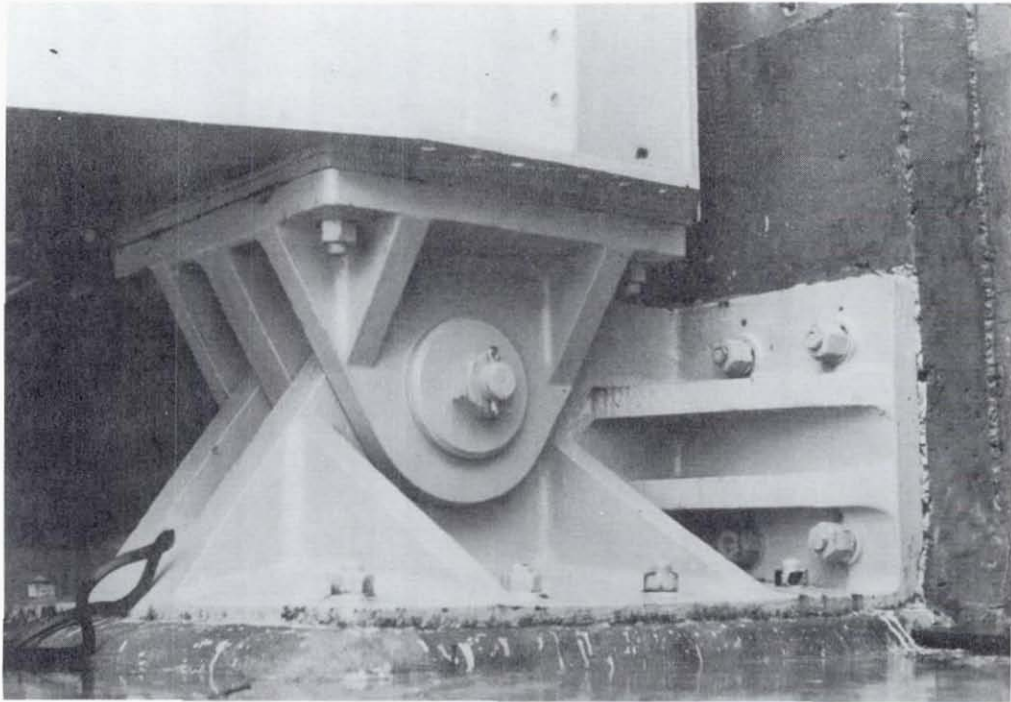

Figure 7.35 Kitakami Ohashi Bridge. Detail of a seismic bearing device at the abutment.

Figure 7.36 Road damage and temporary stabilization of the Kitakami Dike near the bridge site.





Figure 7.37 Spalled concrete at bent cap of Kimazuka Bridge.

Figure 7.38 Longitudinal displacement of superstructure. Note the temporary structure which spans the dislodged main span.





Figure 7.39 Vertical displacement of dislodged span.

Figure 7.40 The Maiya Ohashi Bridge.



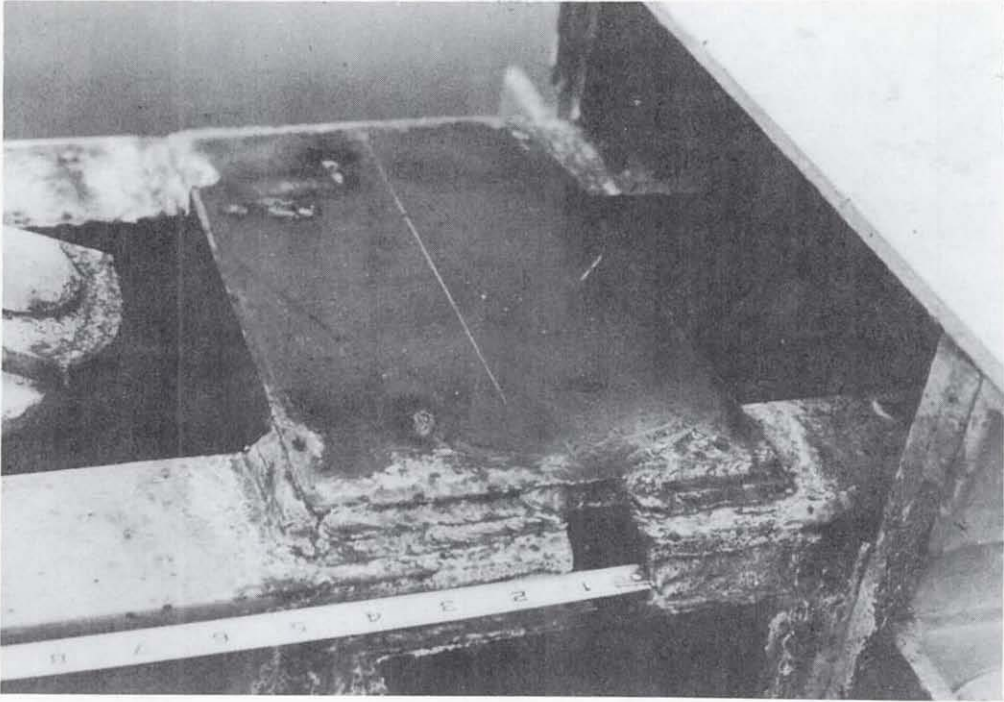

Figure 7.41 Maiya Ohashi Bridge. Steel plates welded to the top chord channel members. Note the clean fracture at a line passing through the centerline of the rivet holes of the lattice bracing and the permanent 2.5 cm separation.

Figure 7.42 Maiya Ohashi Bridge. Buckled lateral bracing of the overhead truss.



Toyoma Bridge

The Toyoma Bridge is a 13-span concrete T-beam bridge constructed in 1945, (Figure 7.43). Prior to the earthquake, the bridge, located about 60 km northeast of Sendai, was restricted to automobile traffic because of damage suffered during the February 20, 1978, earthquake. The bridge was closed following the June earthquake. Flexural induced cracking of the girders occurred at the center of the spans and at the haunched ends over the piers. Shear cracking was also noted at the corners of the concrete hinge seats of several suspended spans. The ground motion, between 0.1 and 0.2g, was sufficient enough to induce pavement cracking of the roadway.

7.4 HIGHWAY DAMAGE

Widespread highway damage (e.g., Figure 7.44) occurred in the region north and east of Sendai. Typical damage included settlement of bridge approaches, cracking of pavements, failure of roadway embankments, and blockage of roads from rockslides. This type of damage has been documented in reports on previous large earthquakes in Alaska, Japan, California, and Guatemala and is virtually impossible to design against.

A major toll road expressway, owned and operated by the Japan Highway Public Corporation, experienced pavement cracking in numerous spots where fill material was used. Additional settlement occurred at the approach to bridges along the expressway which was closed from the time of the earthquake until 7:00 a.m., June 15, while temporary repairs were made.

Reinforced concrete approach settlement slabs were used at many of the bridge abutments. Use of the slabs forced settlement to occur at the end of the slab instead of at the abutment, as illustrated in Figure 7.45.

In areas of rugged terrain, particularly along the West Coast of Japan, roadways are protected against earthquake induced landslides by stabilizing the steep slopes above the roadway with a covering of shotcrete. Rockslides are contained or controlled by emplacing wire mesh screening which is anchored and hung from the crest of the slope and extends down to the roadway or by the construction of rock bins at the base of the roadway cut (see Figures 7.46 and 7.47). These techniques worked quite well in the January 1978 Off-Izu earthquake, but were not utilized in the area affected by the June earthquake.

7.5 RAILROAD DAMAGE

The Japanese electric railroad serves a vital role in Japan. The train is relied upon by most Japanese in major cities such as Sendai as the means of commuting between home and work. The train is also the most popular form of intercity travel within Japan. Major damage was reported at one rail station when the retaining wall supporting the boarding platform collapsed, resulting in track blockage. The main Sendai train station, including the structural portion of the electrification system, was reportedly undamaged. However, the trains were inoperative because of massive power failures. Several rail bridges were severely damaged and are discussed below.

Eai River Rail Bridge

The Eai River Bridge (Figure 7.48), owned by the Japanese National Railways (JNR), is a dual eight-span steel plate girder structure 160 m in length, which is located 40 km northeast of Sendai. The superstructure is supported by massive unreinforced concrete gravity piers on caisson foundations. Ground acceleration in the area was estimated by the Ministry of Construction to be 200-250 gal. Two piers were severely damaged when large wedged shaped sections of concrete dropped out below a construction joint.

The JNR New Sendai Shinkansen Trunkline

JNR is constructing the New Sendai Shinkansen Trunkline, a series of elevated structures for the fast train, extending through Miyagi Prefecture to the northern tip of Honshu. The line is scheduled for completion in 1981. The majority of the elevated structures, a series of prestressed concrete T, I, and box girders with varying configurations of single and multiple column bents, are completed and experienced varying degrees of damage, namely to the



Figure 7.43 General view of the Toyoma Bridge which was closed to traffic. The columns in the background support an independent steel box girder pedestrian structure which was undamaged.

Figure 7.44 Typical Road Fill Failure.

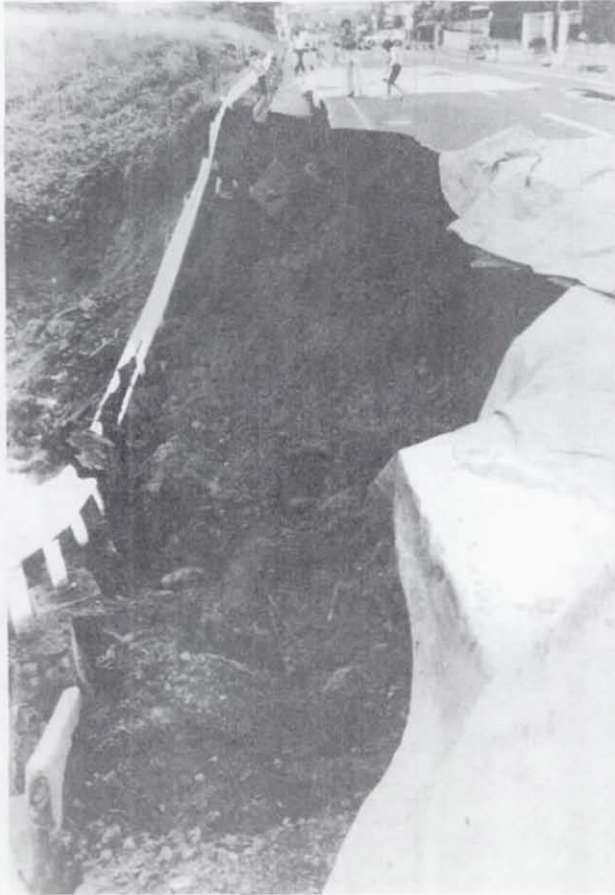

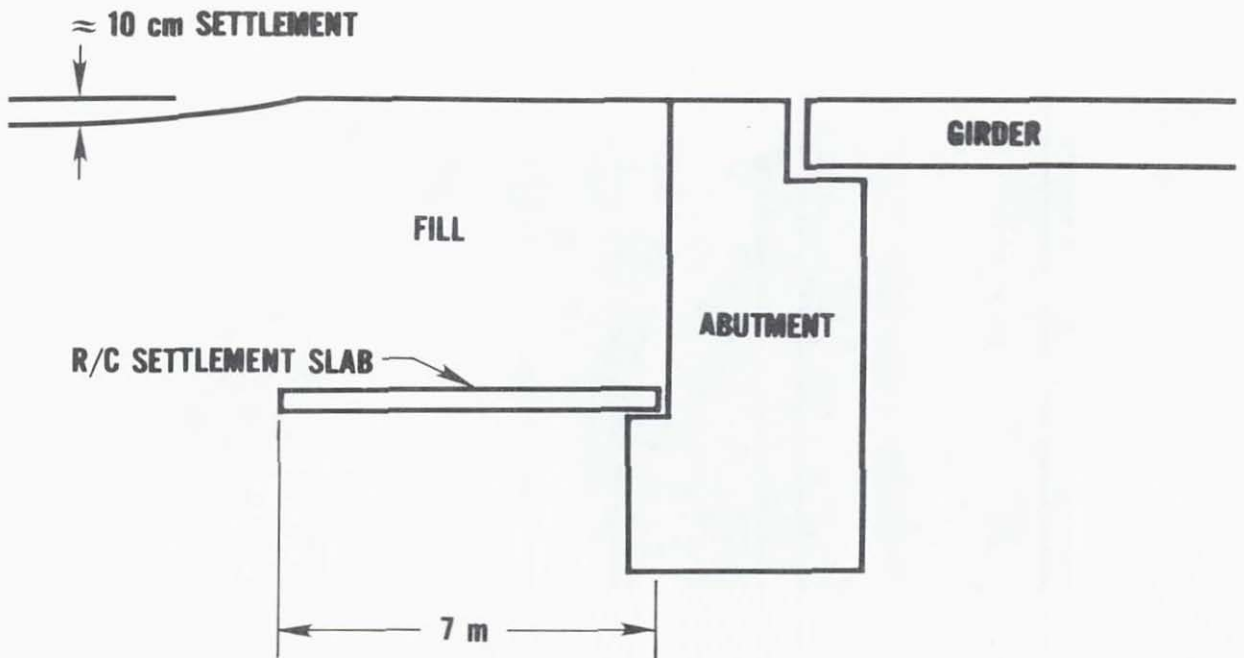
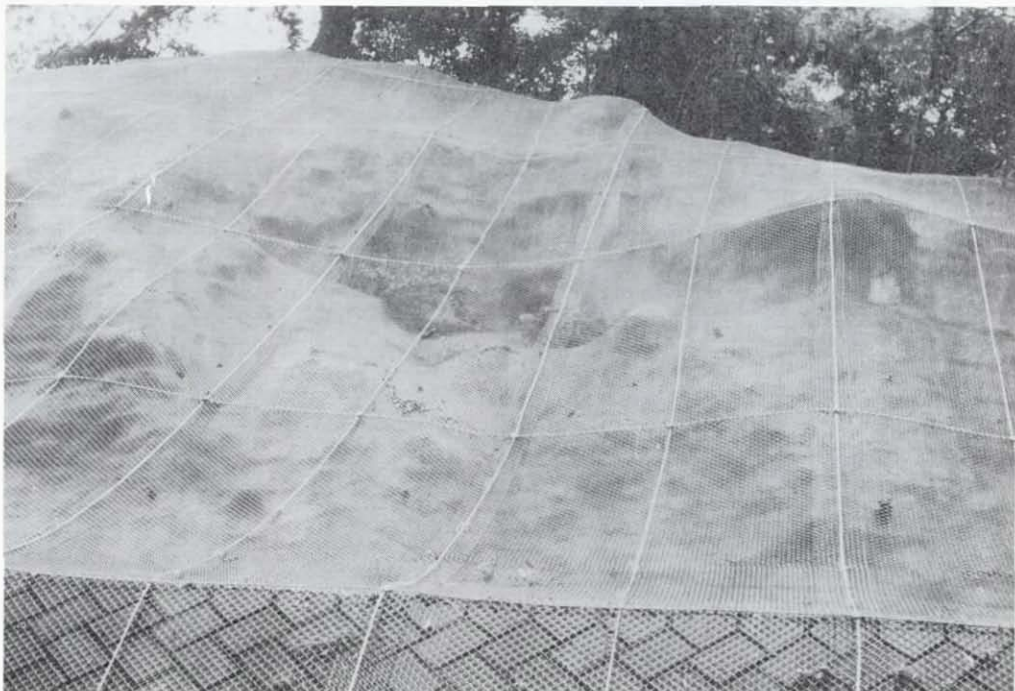

Figure 7.45 Detail of Reinforced Concrete Approach Settlement Slabs.

Figure 7.46 Wire mesh screening used to contain land and rockslides along highways.



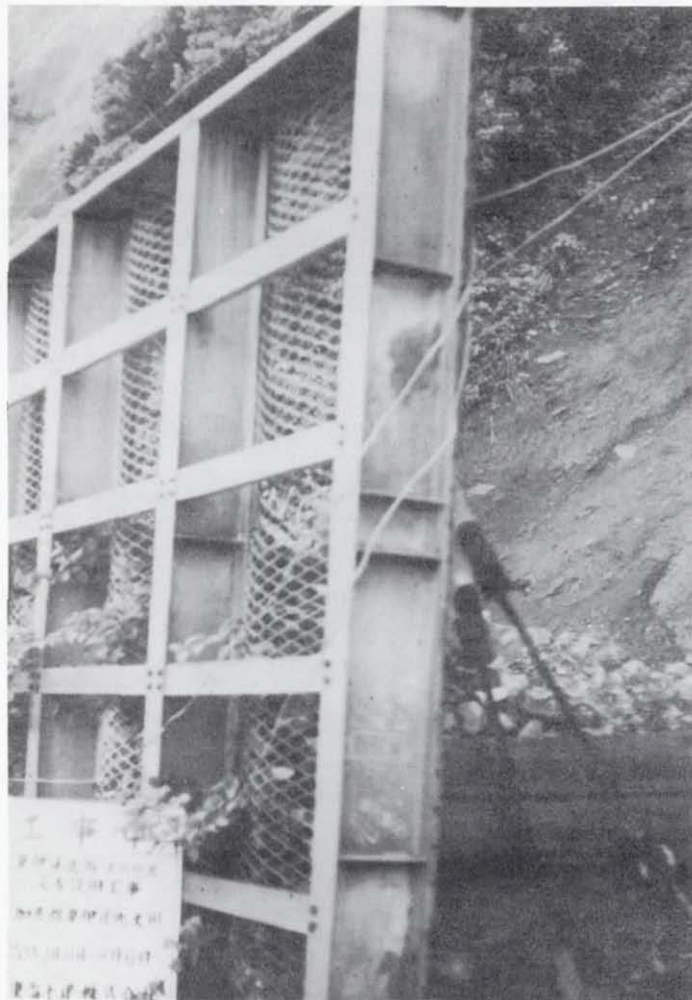

Figure 7.47 Steel bins constructed to contain rockslides along highways.

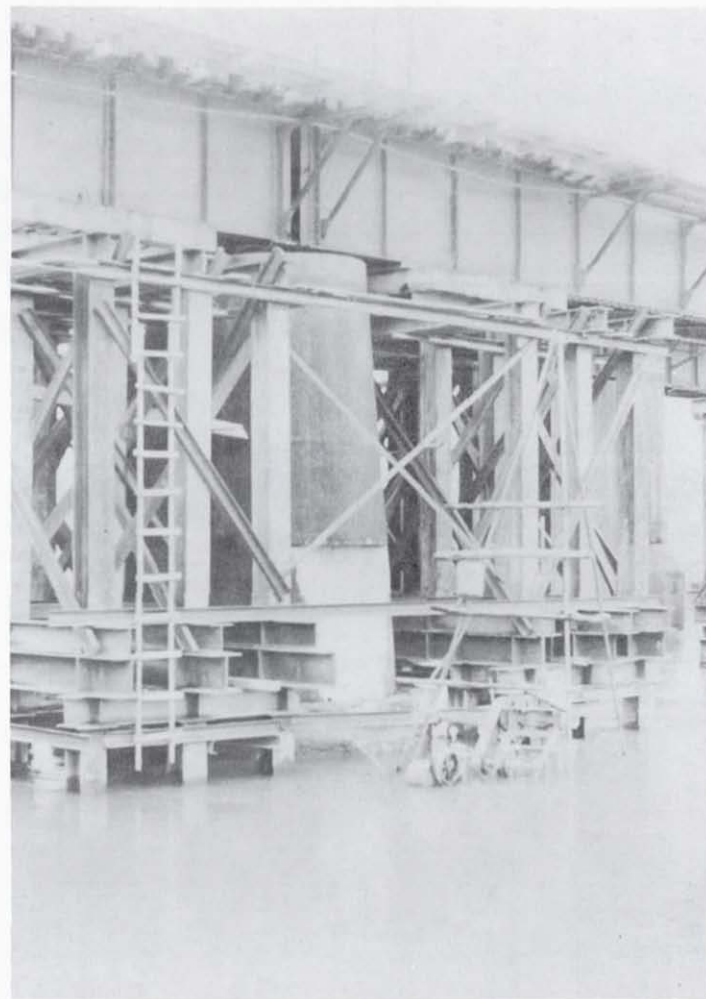

Figure 7.48 Eai River Bridge. Damaged pier of Eai River Rail Bridge. Temporary pier supports were constructed following the earthquake. Full train service was established approximately 10 days after the earthquake.

bearing shoes and columns (see Figures 7.49 - 7.54). Damage was concentrated to those new structures located approximately 30 to 40 kilometers northeast of Sendai. All structures were designed using the 1971 Japanese seismic code.

7.6 TUNNEL PERFORMANCE

Five short, unreinforced concrete-lined highway tunnels through rock, located about 20 km northeast of Sendai on National Highway Route 45, suffered no apparent damage (e.g., Figure 7.55). The Japanese National Railways reported that one concrete-lined tunnel on the Sendai New Shinkansen Line about 40 km northeast of Sendai had hairline cracking.

7.7 CONCLUSION

The June 12 Miyagi-ken-oki earthquake demonstrated the ability of the Japanese Government, both local and national, to respond to the adverse conditions created by a major natural disaster. Specifically, the prompt enactment of their disaster response plan alleviated major problems which could have resulted from the prolonged loss of major transportation routes. The plan allowed for the immediate identification of damaged structures, emergency temporary repairs, and initiation of permanent repair within a matter of days after the earthquake. Major routes, although severely damaged, were opened to traffic within three days after the earthquake.

Bridge substructures which were severely damaged were massive reinforced concrete piers, which responded essentially as non-ductile, rigid bodies to the earthquake motion. In spite of the major damage of these elements, the designs proved satisfactory in that collapse was avoided and the bridges remained operational for emergency use. Although this type of construction proved successful, it would be prohibitively expensive for use in the United States where the philosophy is to utilize more ductile, energy absorbing designs.

Evidence of pier tilting and abutment movement existed which probably caused rather extensive damage to bridge bearing devices. This type of movement is exceptionally difficult to control. This damage indicates the need to perform in-depth site investigations in areas where high water tables exist and to make special considerations in foundation design.

The Kin-noh Bridge was being repaired as a result of damage induced by the February 20 earthquake. Bearings were being strengthened and spans were being restrained at their expansion joints. The failure of the suspended span which had not been retrofitted could be expected and demonstrates once again the need to provide for continuity of the superstructure across all joints.

Damage to bridges inflicted by this and past earthquakes reinforces the need to consider an aggressive retrofit program for those structures built under older seismic design criteria. The most vulnerable components requiring retrofit are bearings and columns, including connections into the foundation. Modest investments can significantly reduce future damage and help to avoid collapse of older, important structures.

As in previous earthquakes, significant damage occurred to roads in the area of strong ground shaking. Embankments fail, fill material settles, and land- and rockslides block roads and trackage. These types of damage are difficult to control, although stabilization and control techniques utilized by the Japanese do help. Special consideration, including the use of control and stabilization techniques described earlier in this chapter and/or the development of specific emergency response plans in susceptible areas, should be given to those important routes which must remain open following a major earthquake.

Given the magnitude of the Miyagi-ken-oki earthquake, transportation structures in general performed very adequately. Air, train, bus, and highway travel, although temporarily interrupted, did not adversely hinder emergency operations or affect the general movement of commerce or people.

7.8 REFERENCES

- 7.1 "Earthquake Resistant Design for Civil Engineering Structures, Earth Structures, and Foundations in Japan," compiled by the Japan Society of Civil Engineers, Tokyo, Japan, 1977.
- 7.2 "Standard Specifications for Highway Bridges," Twelfth Edition, American Association of State Highway and Transportation Officials, Washington, D.C., 1977.

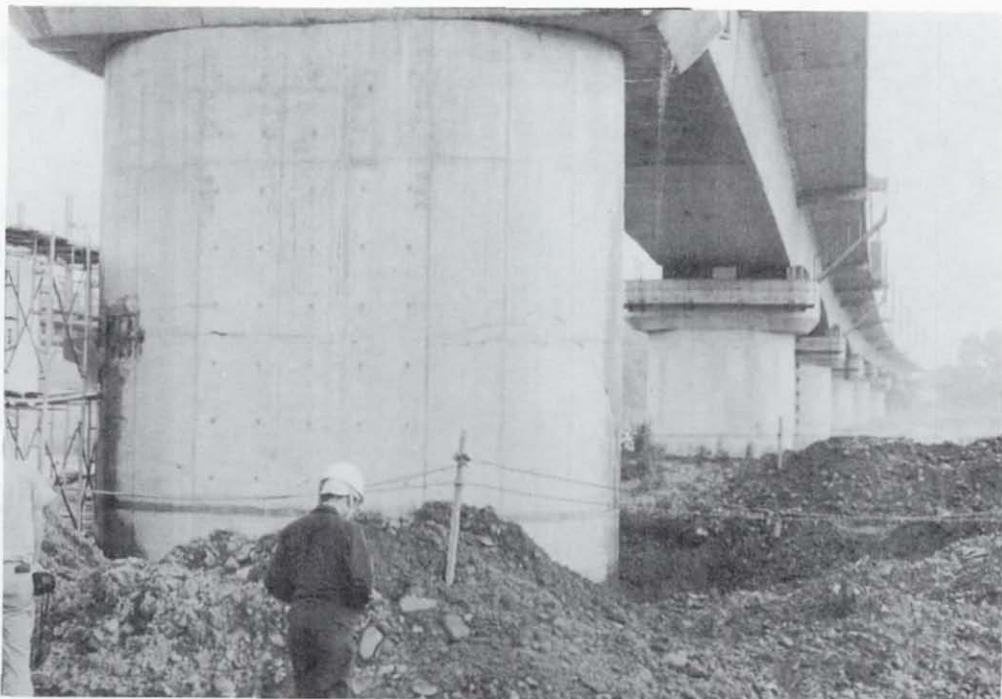

Figure 7.49 The Natori River Bridge is a three-span continuous single cell reinforced cast-in-place concrete box girder structure on 3 m x 6 m piers approximately 8 meters above grade. Typical damage included cracking in the central part of the pier where the gross cross-sectional area of vertical steel was reduced.

Figure 7.50 Natori River Bridge. Detail of spalled concrete at the Natori River Bridge site showing the buckled vertical rebar.





Figure 7.51 Typical structures which experienced pier cracking near the Rifu Construction Office of the Sendai Shinkansen Construction Bureau, JNR.

Figure 7.52 Shear cracking in the relatively lightly reinforced upper portion of the pier.



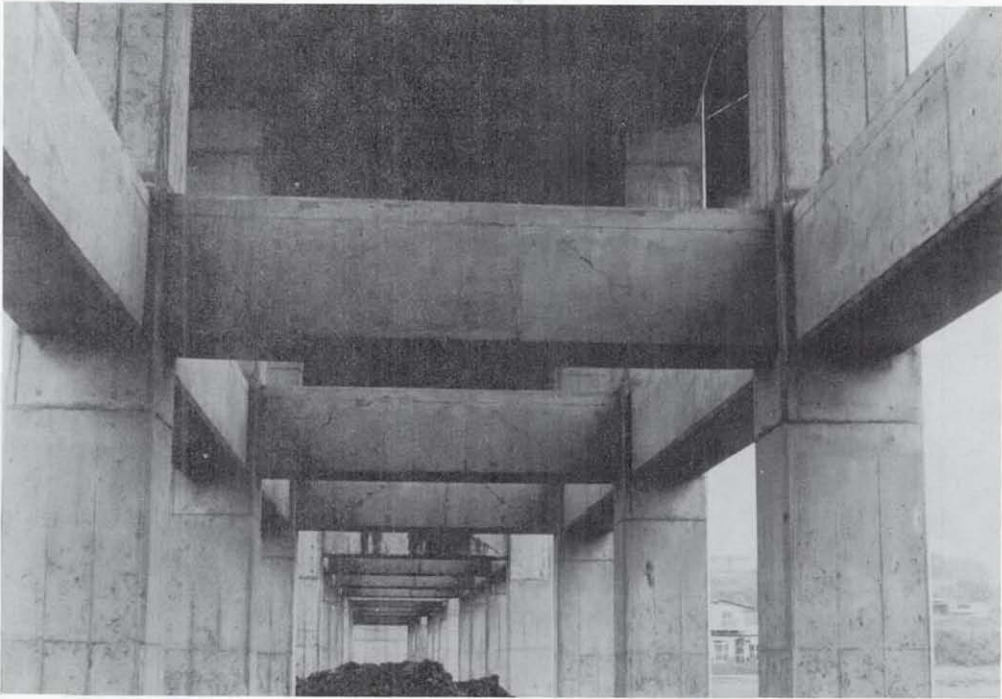

Figure 7.53 Tensile cracking of space frame tie beams near the Rifu Construction Office.

Figure 7.54 Failure of a bearing plate supporting a single cell box girder near the Higashi Sendai Construction Office. Girder displaced laterally 50 cm.



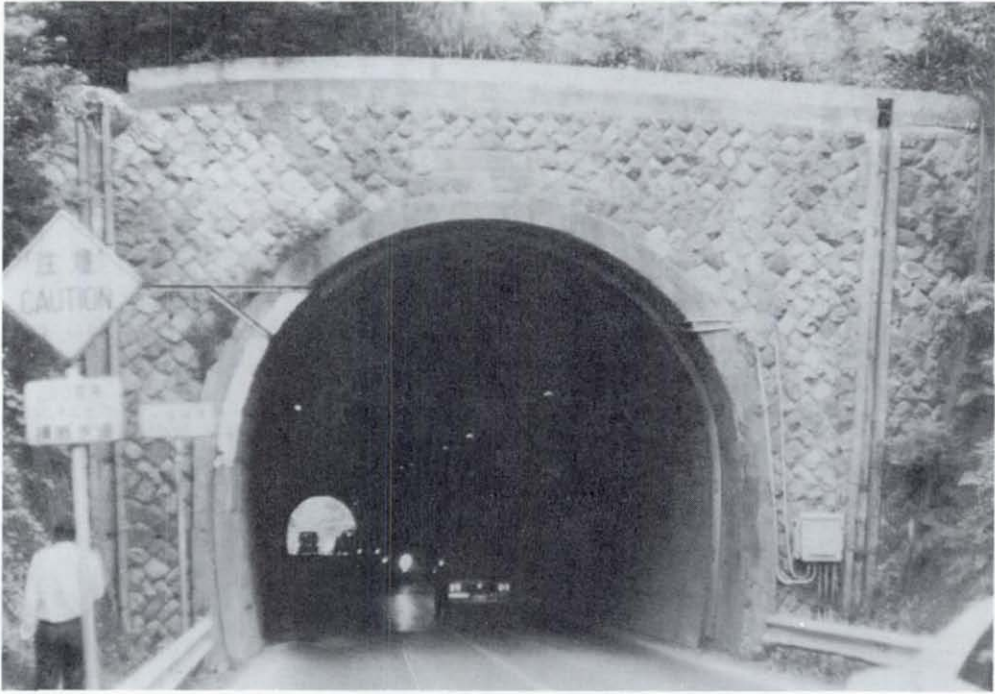

Figure 7.55 Typical undamaged highway tunnel on Route 45 along the coast between Sendai and Ishinomaki to the north.

8. LIQUEFACTION AND DAMAGE TO DIKES*

8.1 INTRODUCTION

The June 12, 1978, Miyagi-ken-oki earthquake caused soils to liquefy at several sites on the coastal flood plain bordering the Bay of Sendai. The engineering structures most extensively damaged by liquefaction were flood-control dikes composed of earth fill. The damage consisted primarily of cracking, settlement, and minor lateral spreading and slumping. During a trip to Miyagi Prefecture on June 26, 1978, six sites were visited where dike damage had occurred (Figure 8.1). Additional information on earthquake-induced dike damage was provided by officials of the Public Works Research Institute (PWRI), the Japanese government agency charged with building and maintaining river works. Liquefaction-induced damage also occurred in an uncompacted sand fill in the port of Ishinomaki.

8.2 SUMMARY OF DIKE DAMAGE

Reported damage sites are scattered in an arc extending from the Abukuma River on the southwest to the mouth of the New Kitakami River on the northeast (Figure 8.1). Within this region, damage occurred along parts of the Abukuma, Natori, Hirose, Yoshida, Eai, Naruse, Old Kitakami, and New Kitakami rivers (Figure 8.1, Table 8.1). Most or all sites are underlain by unconsolidated Holocene coastal flood plain deposits; a few may be underlain by Holocene alluvial fan deposits (Geological Survey of Japan, 1968; Geologic Map of Miyagi Prefecture). Many of the damaged dikes are founded on river channel deposits less than 500 years old. Because of the proximity of all dikes to rivers, the water tables under them are close to the ground surface at all times. A total of 28 linear kilometers of dikes was damaged in this earthquake, and total repair costs of dikes and other river works amounted to about 10 billion yen (approximately \$50 million) (Ministry of Construction of Japan, unpublished data). Most of this damage was caused by liquefaction.

The dikes are composed chiefly of compacted sand. They are built directly on alluvial fan or flood plain sediments with little or no ground improvement. Most dikes are several meters high, several meters wide at the crest, and have side slopes of 2 Horizontal: 1 Vertical or less. At the time of the visit, repairs to the dikes were already well advanced. The repairs consisted of regrading and filling cracks, placing sand bags, and driving steel sheet piles to reduce seepage under the dikes.

8.3 GEOLOGIC SETTING

Most sites of damage are on the coastal plain bordering the Bay of Sendai; a few are on the margin of Natori River alluvial fan and may be underlain by alluvial fan deposits (Geological Survey of Japan, 1968; Geologic Map of Miyagi Prefecture). The coastal plain sediments are unconsolidated Holocene gravels, sands, silts, and clays primarily deposited by rivers; beneath most dikes these deposits are several tens of meters thick (Hase, 1967). The river deposits are of three main types: channel, natural levees, and back marsh deposits (Tohoku Regional Construction Bureau, MoC, unpublished data; H. Nakagawa, Tohoku University, unpublished data). Engineering structures including dikes founded on channel or back marsh deposits performed relatively poorly during the earthquake. Liquefaction occurred most commonly in channel deposits.

Performance of engineered structures founded on natural levee deposits varied from place to place. These deposits are generally thin, and the performance of structures was therefore strongly influenced by the materials underlying the natural levees (H. Nakagawa, Tohoku University, oral communication). Structures near the coast, founded on beach ridge and dune sand deposits sustained little damage in the earthquake. Natori River alluvial fan materials consist primarily of gravel but also contain a few thin layers of sand and silt (Hase, 1967).

* Prepared by David K. Keefer, U.S. Geological Survey, Menlo Park, California.

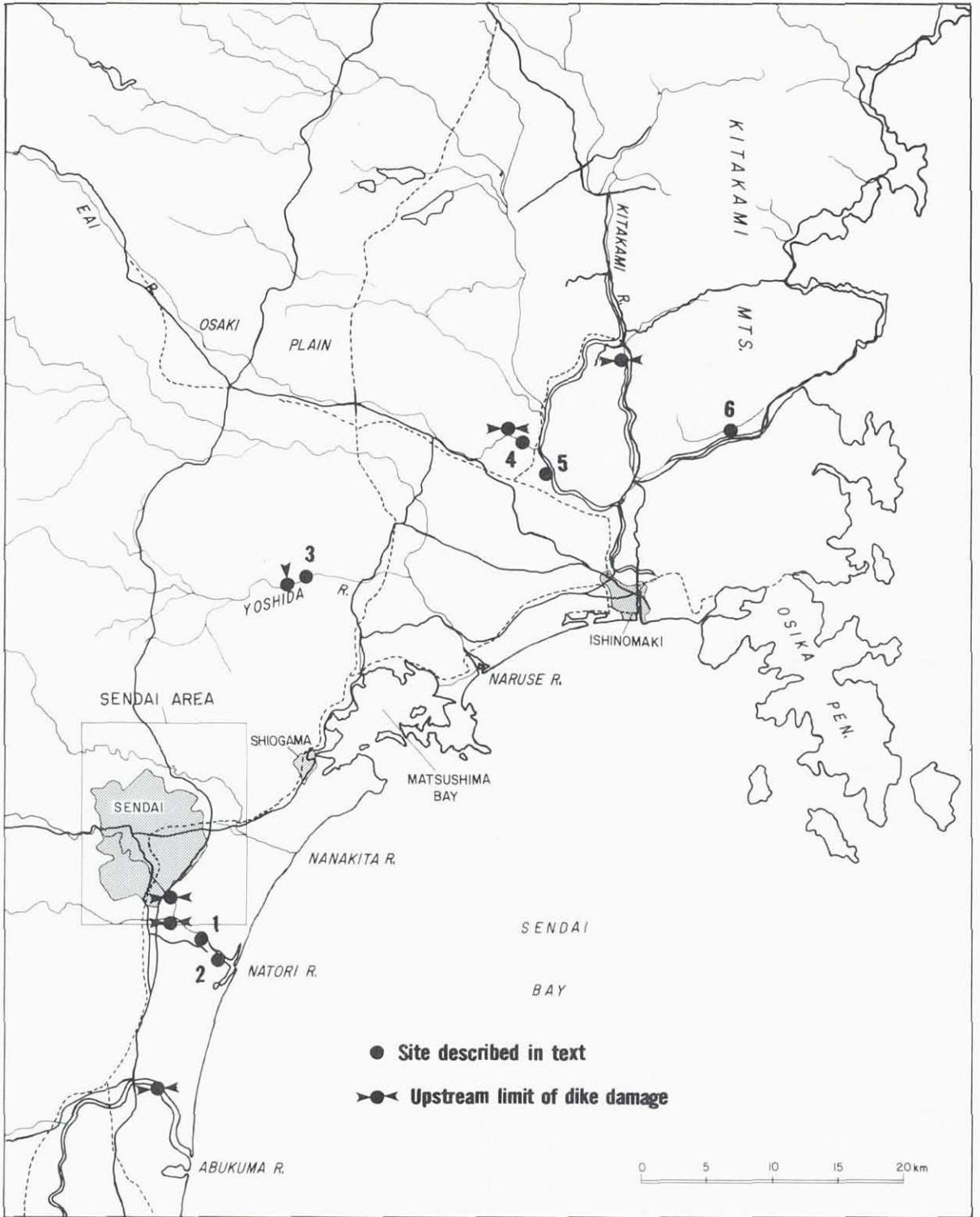

Figure 8.1 Dike Damage in Miyagi Prefecture

TABLE 8.1

DIKE DAMAGE IN MIYAGI PREFECTURE

River	Bank ¹	Number of damage sites	Total length of dike affected by cracking, settlement, lateral spreading, or slumping (kilometers)
Abukuma	left	2	0.38
	right	5	0.68
Natori	left	11	1.87
	right	6	2.17
Hirose	left	0	0
	right	5	0.38
Yoshida	left	9	0.51
	right	12	5.50
Eai	left	5	2.90
	right	6	0.21
Naruse	left	13	0.79
	right	10	1.08
Old Kitakami	left	3	0.15
	right	9	0.29
New Kitakami	left	16	7.13
	right	17	4.13
TOTAL		129	28.17

Information furnished by the Tohoku Regional Construction Bureau.

¹ Right or left relative to an observer facing downstream.

8.4 FIELD OBSERVATIONS OF DIKE DAMAGE

8.4.1 Natori River (Sites 1 and 2)

Lateral spreads, fissures, and sand boils were apparently widespread along the Natori River for 3 km upstream from its mouth (T. Tazaki, PWRI, oral communication). In this area the flood plain is underlain by fluvial sand that extends to a depth of 15 m or greater (Hase, 1967). Two damaged dikes in this area (Figure 8.1) were visited.

At Site 1, liquefaction caused slumping, lateral spreading, and settlement of up to 1.5 m along a 160-m-long section of the dike (Figures 8.2, 8.3, and 8.4). Longitudinal cracks several tens of meters long opened in the dike crest. Between the dike and the river, fissures striking obliquely to the dike formed, and sand was ejected from them (Figure 8.5). Other fissures trending parallel to the dike and the river formed near the river bank, more than 100 m from the base of the dike. The occurrence of fissures and sand boils in ground away from the dike indicates that liquefaction took place primarily in material beneath the dike and not in the dike material itself.

The configuration (Figure 8.4) and composition of this dike are typical of those seen throughout Miyagi Prefecture. The dike is composed primarily of compacted, fine to medium sand. It rises 2 m above the high water level of the river and is 4 m wide at its crest. Its riverward flank has a slope of 2H: 1V. The opposite flank descends as a series of slopes (2H: 1V) and benches to the agriculture land beyond.

The damaged section is built on a former channel abandoned by the river less than 500 years ago. Beneath the dike, fluvial sand extends to a depth of at least 60 m (Hase, 1967), and much of the top 15 m of sand is fine grained, loose, and well sorted (poorly graded) (Tohoku Regional Construction Bureau, MoC, unpublished data).

Liquefaction previously took place at this site during a M 6.7 earthquake in February 1978 (T. Tazaki, PWRI, oral communication). The same section of dike was affected and the same materials liquefied in both the February and June earthquakes.

At Site 2 (Figure 8.1), the dike is contained by a concrete retaining wall (Figures 8.6, 8.7, 8.8, and 8.9). A section of the retaining wall several hundred meters long moved about 30 cm toward the river. Longitudinal fissures opened in the dike behind the retaining wall and in a concrete pavement along part of the dike. The dike also settled by as much as 30 cm. This site, at the mouth of the river, is underlain by at least 20 m of sand (Hase, 1967).

8.4.2 Yoshida River (Site 3)

This was one of the most severely damaged sections of dike in Miyagi Prefecture. Settlements of up to 1 m occurred over a distance of 5 km, longitudinal cracks and scraps formed in the dike crest, bulges appeared in the lower slopes, and sand boils occurred along some cracks (Figures 8.10, 8.11, 8.12, and 8.13). The cracks and bulges indicate that lateral spreading and slumping took place. The damaged section rests on the fan-delta of a small stream, and a boring near this site penetrated 15 m of silt, 2 m of fine sand, and 5 m of coarse sand (Tohoku Regional Construction Bureau, MoC, unpublished data; Hase, 1967). Bedrock lies at an average depth of 35 m.

8.4.3 Eai River (Site 4)

Sand boils were common in an old river channel at Site 4, on the right bank of the Eai River (Figure 8.14). A concrete block fence near this channel was cracked by lateral spreading toward the old channel bank (Figure 8.15). Damage to the dike on this side of the river was minor. Across the river from Site 4, cracks up to 80 cm deep and 10 cm wide occurred in the dike. On both sides of the river, the foundation material contains much soft clay. Some layers of silt and sand may also be present. It was reported that the dikes were built relatively slowly, and significant settlement took place during construction (K. Kawashima, PWRI, oral communication).



Figure 8.2 Site 1, Natori River, view downstream (southeast) along repaired portion of dike. Dike is made of compacted sand. It rises 2 m above the high water level of the river and has side slopes of 2H:1V. Natori River in center-left background.

Figure 8.3 Site 1, Natori River. Slumping of dike on flank away from river. View north. (Photo courtesy Tohoku Regional Construction Bureau)



Figure 8.4 Site 1, Natori River--cracking, settlement, slumping, and lateral spreading induced by liquefaction. (From Tohoku Regional Construction Bureau, MOC, unpublished data)

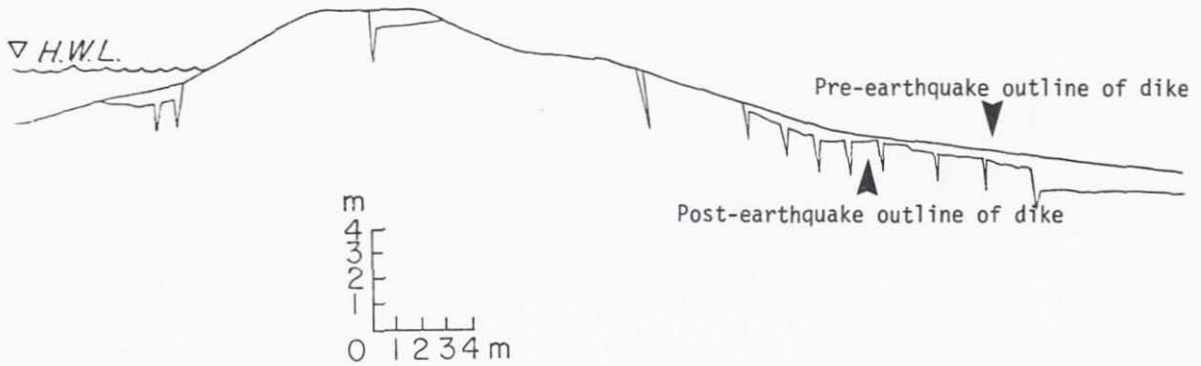

Figure 8.5 Site 1, Natori River. Liquefaction-induced cracks and sand boils in ground between river and dike indicate that liquefaction took place in materials beneath the dike. Sand in center-ground to left of crack is from sand boil. Sand bags on dike were placed after the earthquake as a repair measure. View is south.



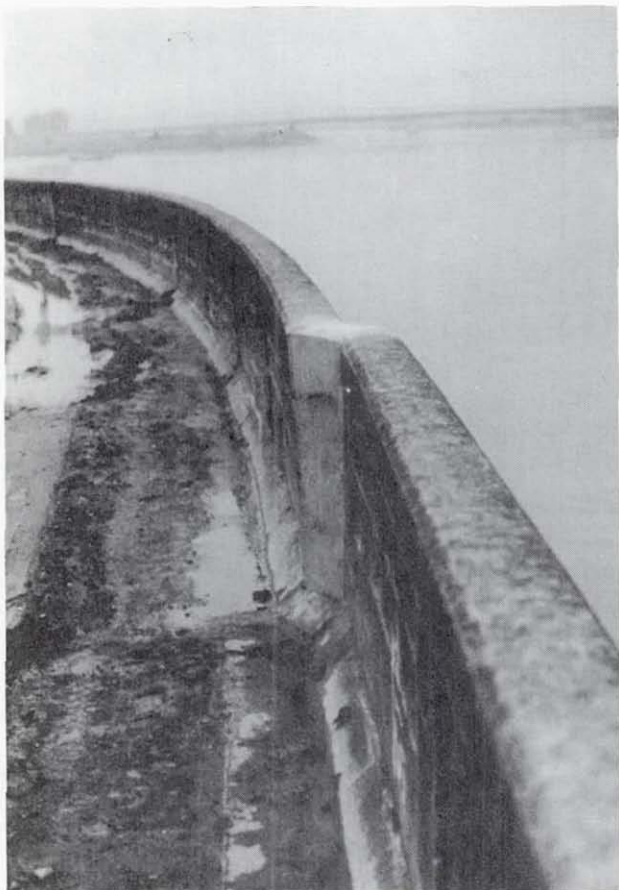

Figure 8.6 Site 2, Natori River. View is west along repaired portion of dike. Note patch across offset in retaining wall offset caused by lateral spreading during earthquake. Retaining wall rises approximately 1 m above roadway.

Figure 8.7 Site 2, Natori River. Settlement, lateral spreading, and longitudinal cracking of dike. View is east.
(Photo courtesy Tohoku Regional Construction Bureau)





Figure 8.8 Site 2, Natori River. View is west across tributary of Natori River. Dike section shown in Figs. 8.6 and 8.7 is to right of houses in background of this figure. Note crack in concrete pavement in foreground is aligned with crack in retaining wall in background.

Figure 8.9 Site 2, Natori River--Retaining wall moved laterally and dike crest settled (From Tohoku Regional Construction Bureau, MOC, unpublished data)

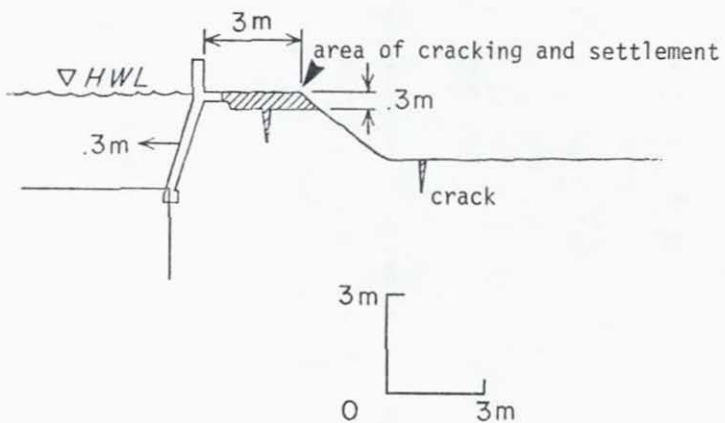

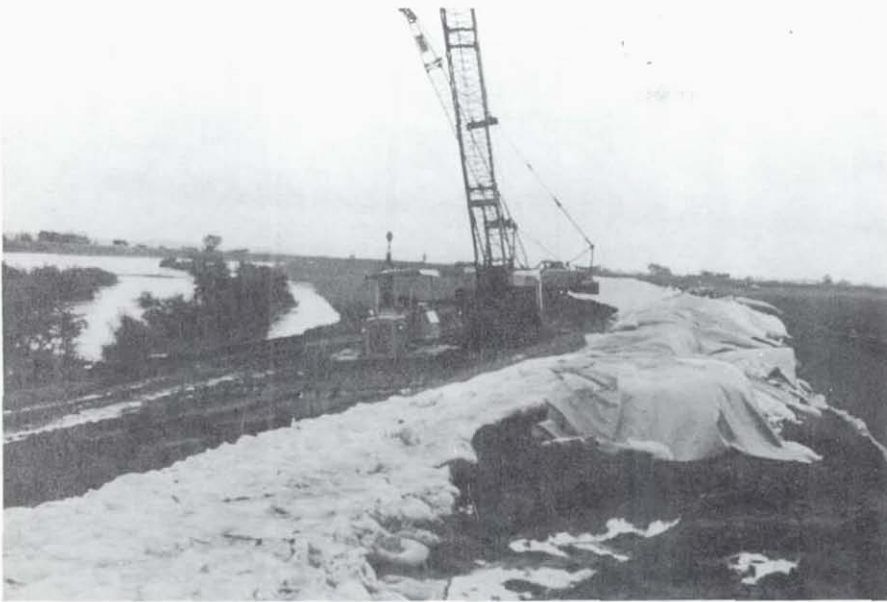

Figure 8.10 Site 3, Yoshida River. View east (downstream) along section of dike where repairs are underway. Dike crest settled as much as 1 m over a length of 5 km. Sand bags have been placed as part of repair process.

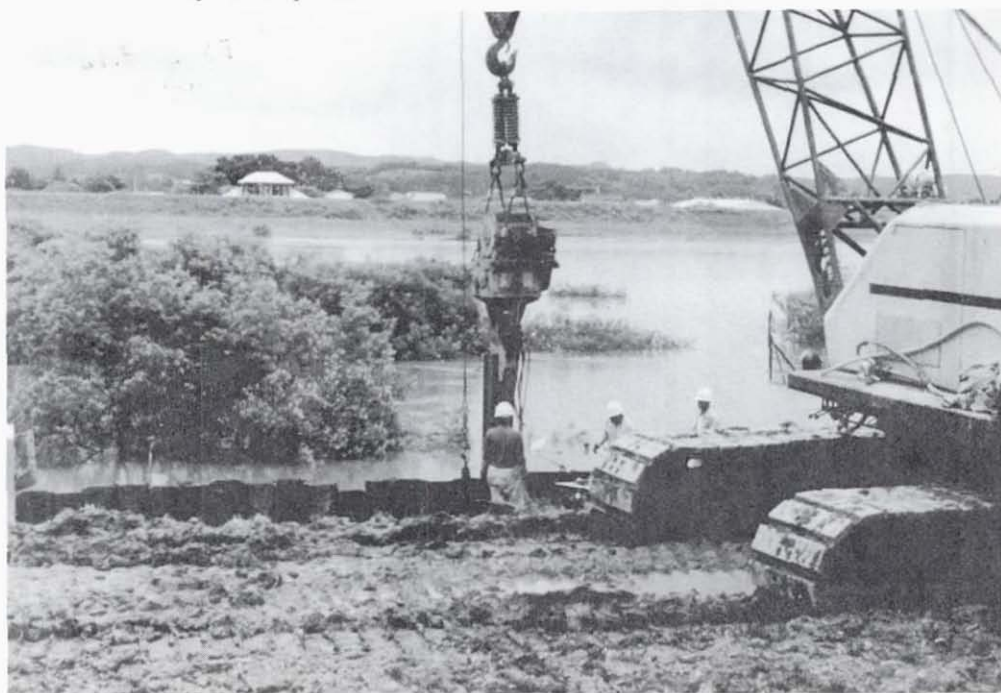

Figure 8.11 Site 3, Yoshida River. Cracks in dike caused by slumping and lateral spreading. Cracks are 10-30 cm wide. View is west. (Photo courtesy K. Kawashima, PWRI)



Figure 8.12 Site 3, Yoshida River. Scarps in dike caused by slumping. Note man in background for scale. (Photo courtesy K. Kawashima, PWRI)

Figure 8.13 Site 3, Yoshida River. Steel sheet piles being placed by vibratory driver as part of repair process. Purpose of sheet piles is to reduce seepage under part of dike weakened by earthquake.



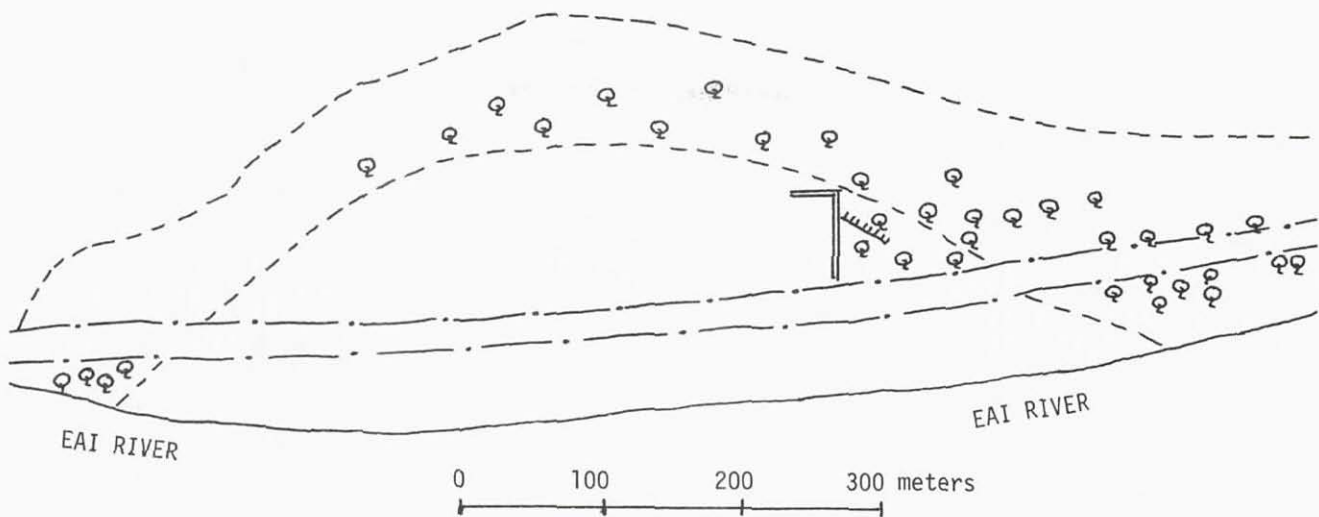

LEGEND

- Q Sand boil
- - - - - Dike
- · · · · Old river channel
- ||||| Ground crack caused by lateral spreading
- └┘ Concrete block fence

Figure 8.14 Site 4, Eai River--Most sand boils occurred in old river channel. Minor cracking of dike apparently occurred where dike crosses old channel, but cracks were repaired prior to visit. (After Tohoku Regional Construction Bureau, MOC, unpublished data)

Figure 8.15 Site 4, Eai River - View southwest from crest of dike. Crack (indicated by heavy line) in fence and rice field caused by lateral spreading toward bank of old channel in background.

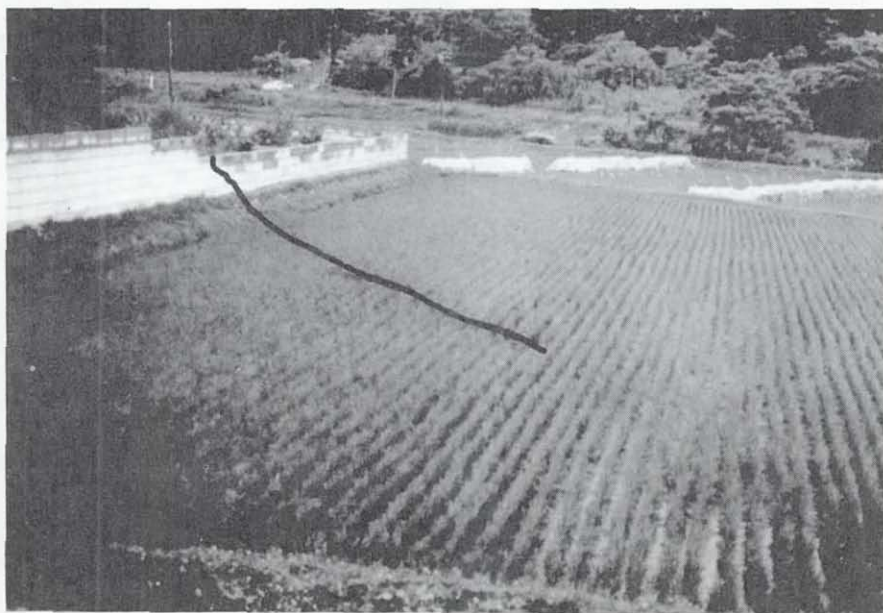

8.4.4 Old Kitakami River (Site 5)

Sand boils occurred in the rice field adjacent to the dike (Figure 8.16), but damage to the dike itself was apparently minor. Subsurface material at Site 5 consists of alternating layers of silty sand and clay to a depth of 15 m. (T. Tazaki, PWRI, oral communication).

8.4.5 New Kitakami River (Site 6)

The dike and paved roadway at Site 6 settled up to 1.5 m and cracked over a distance of 4 km (Figures 8.17 and 8.18), and sand boils formed on both flanks of the dike, which is built over an old river channel. According to data from borings completed by the Tohoku Regional Construction Bureau, MoC, the soil under the damaged part of the dike is similar to the soil under an adjacent, undamaged section. To a depth of 8 in, the soils consist of gravels, sands, and silts with a few thin layers of clay. N-values (blows/foot from a standard penetration test) for most soil layers under both sections are less than 10. Reasons for the differences in behavior between damaged and undamaged sections are currently under study by Japanese engineers.

8.5 LIQUEFACTION IN THE PORT OF ISHINOMAKI¹

In the port of Ishinomaki, a fine-sand fill liquefied, causing severe damage to anchored steel-sheet-pile bulkheads. The fill material had been dredged from the seafloor and placed hydraulically with no compaction. It was placed next to old beach deposits, and the boundary of the liquefaction damage followed the contact very closely; the beach deposits were not involved in the liquefaction.

8.6 CONCLUSION

The Miyagi-ken-oki earthquake caused cracking, settlement, lateral spreading, and slumping of man-made dikes along several rivers in the prefecture. Most of the damage was due to liquefaction. A total of 28 linear km of dikes were damaged, and total damage to dikes and other river works was approximately \$50 million. Liquefaction also occurred in hydraulic fill composed of fine sand in the port of Ishinomaki. These effects are currently being investigated by several Japanese scientists and engineers; some reports have already been published (Yoshimi and others, 1978; Okubo and Ohashi, 1979; Tatsuoka and others, 1979; Yamamura and others, 1979), and other reports should be forthcoming in the near future.

8.7 REFERENCES

1. Geological Survey of Japan, 1968, Hydrogeological Map of the Coastal Region of Bay of Sendai. Hydrogeological Maps of Japan 16, 1 map, scale 1: 100,000.
2. Geologic Map of Miyagi Prefecture, scale 1: 200,000 (legend in Japanese).
3. Hase, Kotaro, 1967, Geology of the Alluvial Plains of Miyagi Prefecture (in Japanese with English figure captions), Contributions from the Institute of Geology and Paleontology, Tohoku University, No. 64, 45 p.
4. Okubo, T., and Ohashi, M., 1979, Miyagi-ken-oki, Japan earthquake of June 12, 1978, general aspects and damage, Report distributed at 2nd U.S. National Conference on Earthquake Engineering, Stanford, California, 15 p. (In English)
5. Tatsuoka, F., Ohkochi, Y., Fukushima, S., Igarashi, H., and Yamada, S., 1979, Soil liquefaction and damage to soil structure during the earthquake off Miyagi Prefecture on June 12, 1978, Institute of Industrial Science, University of Tokyo, Bulletin of Earthquake Resistant Structure Research Center, No. 12, p. 3-13. (In English)
6. Yamamura, K., Iwasaki, T., Sasaki, Y., Koga, Y., Taniguchi, E., and Tokida, K., 1979, Ground failures and damage to soil structures from the Miyagi-ken-oki, Japan earthquake of June 12, 1978, Report distributed at 2nd U.S. National Conference on Earthquake Engineering, Stanford, California, 16 p. (In English)
7. Yoshimi, Y., Tohno, I., and Tokimatsu, K., 1978, A report on the Miyagi-ken-oki, Japan, earthquake of June 12, 1978: Part II: Geotechnical aspects of damage, International Conference on Microzonation, 2nd, San Francisco, Proc., v. 1, p. 600-605. (In English)

¹ Data kindly provided by Mr. Hajime Tsuchida, Chief, Earthquake Resistant Structures Lab, Port and Harbor Research Institute, Ministry of Construction.



Figure 8.16 Site 5, Old Kitakami River ~ Sand boils in rice field. Plants are several centimeters tall. Damage to the dike at this site was minor. (Photo courtesy K. Kawashima, PWRI)

Figure 8.17 Site 6, New Kitakami River. View east along crest of dike and highway that are being repaired. Uneven nature of highway surface is due to liquefaction-induced differential settlement. Settlements of up to 1.5 m occurred along a distance of 4 km.





Figure 8.18 Site 6, New Kitakami River. Cracking of dike crest and roadway due to liquefaction-induced slumping. (Photo courtesy K. Kawashima, PWRI)

9. SEISMIC-INDUCED LANDSLIDES*

9.1 INTRODUCTION

Several thousand landslides were triggered by the June 12, 1978, Miyagi-ken-oki earthquake. Landslides were concentrated within Miyagi and northern Fukushima Prefectures. The landslide distribution was densest along the coast nearest the epicenter from Sendai northeast to the area around Matsushima. Landslides were responsible for 1 death, 1 injury, 2 houses destroyed and 13 houses damaged (Y. Tsuruya, 1978, unpublished data; Tohoku University report, 1979).

Small rock falls and rock slides issuing from steep slopes were the most abundant landslides. Along the mountainous roads of the Ojika Peninsula, these landslides were generally less than 10 m³ in volume and occurred in closely fractured Triassic and Jurassic slate and interbedded quartzite. The largest contained several thousand cubic meters of debris and occurred on natural slopes in tuffaceous deposits near Matsushima and eastward on slopes near the mouth of the Naruse River (Figure 9.1).

Although fewer in number, rotational slumps in artificial fill were larger than most rock falls and slides and caused significant damage to highways and buildings. Such slumps within the city limits of Sendai were responsible for damage and destruction to houses. The poor seismic performance of fills indicates that they could be hazards in future earthquakes.

The author spent approximately three days surveying seismic-induced landslides and their effects from south of Sendai along the Natori River to the mouth of the New Kitakami River. Data included within this report comprises observations from the author's reconnaissance, information provided by Mr. Y. Tsuruya of the Japanese Ministry of Construction, and data from a report published by Tohoku University (1979).

The following descriptions of seismic-induced landslides are presented at site observations (referring to Figure 9.1 for locations of individual landslide sites and local geography). The landslide sites depict noteworthy and representative examples of the different kinds of landslides that occurred in this earthquake. Sites 1 and 4 through 8 are described with the aid of supplemental data and photographs provided by Mr. Y. Tsuruya of the Slope Protection Division, Ministry of Construction, Tokyo.

9.2 ROCK FALLS AND ROCK SLIDES ON NATURAL SLOPES

9.2.1 Site No. 1

Two of the largest rock falls from the earthquake occurred near Takayamashita in Matsushima town west of the Takagi River on steep (greater than 45°) natural slopes. The larger of these rock falls (Figure 9.2) occurred in a deeply weathered and closely jointed Miocene tuff breccia (Geologic Map of Miyagi Prefecture) exposed in a 45-m scarp. The slope affected is approximately 110 m wide, and the volume of debris is about 6,000 m³. The rock fall damaged four houses built next to the slope. A close view of some of the damage to the house second from the left in Figure 9.2 is shown in Figure 9.3.

About 0.5 km to the north, a smaller rock fall occurred on a steep slope in dark brown volcanic rocks (Miocene tuffs (?)). The scarp is about 20 m high and about 50 m wide (Figure 9.4). The debris is blocky and includes boulders up to 2 m in diameter. The scarp reveals extensively fractured bedrock. The fractured surfaces probably provided planes of weakness along which the rock failed.

9.2.2 Site No. 2

Three rock falls occurred on steep east-facing bluffs flanking a broad flood plain near the mouth of the Naruse River. All three were narrow failures, about 15 m wide, that occurred in dark brown volcanic rock similar to the smaller rock fall at Site No. 1. The slides extended from near the crest of the bluffs to the base, a height of approximately 30 m. Two of the slides are shown in Figure 9.5.

* Prepared by Edwin L. Harp, U.S. Geological Survey, Menlo Park, California.

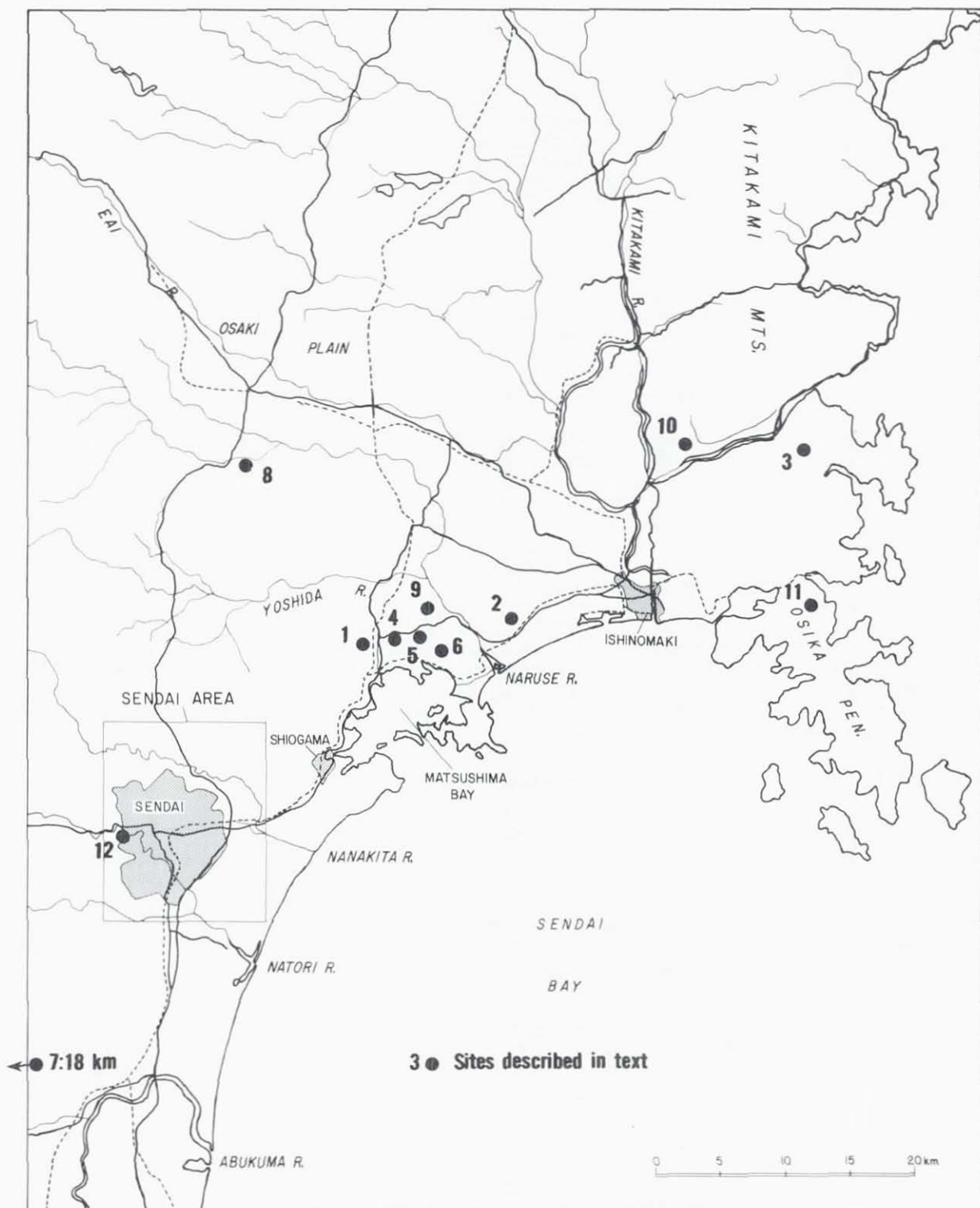

Figure 9.1 Sendai area showing sites of landslides described in text (dots).



Figure 9.2 Rock fall on steep slopes of Miocene pumiceous tuff breccia near Takayamasuita. This rock fall damaged four houses close to the base of the slope. (Photograph courtesy of Y. Tsuruya, Slope Protection Division, Ministry of Construction).

Figure 9.3 Closeup of rock fall damage to houses shown in left portion of figure 9.2. (Photograph courtesy of Y. Tsuruya)





Figure 9.4 Rock fall on steep slopes in volcaniclastic sediments.

Figure 9.5 Rock falls (arrows) in steep bluffs bordering flood plain near mouth of Naruse River.

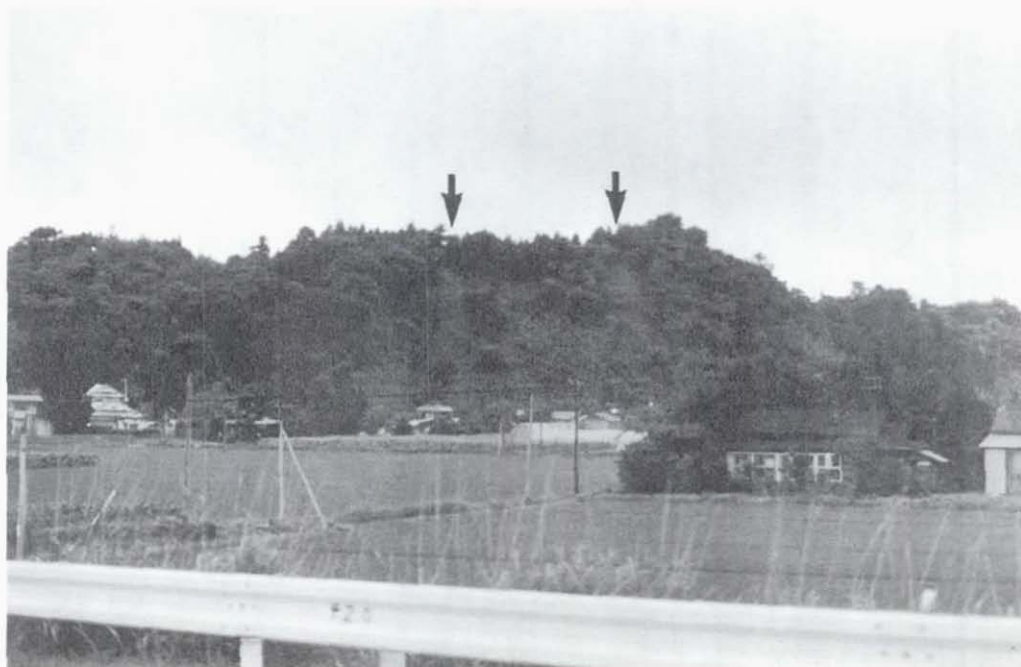

9.2.3 Site No. 3

A small rock fall south of the New Kitakami River occurred on the end of a narrow ridge of Triassic slate and quartzite. Slopes adjacent to this end of the ridge showed no failure, suggesting that this point, which was the narrowest part of the ridge, experienced stronger shaking than adjacent slopes. This phenomenon has been documented in other earthquakes (Bonilla, 1959; Nason, 1971; Harp and others, 1978) and has been attributed to the topographic focusing of seismic energy.

9.3 ROCK FALLS AND ROCK SLIDES IN CUT SLOPES

9.3.1 Site No. 4

Near Atago in Matsushima, approximately 1.0 km east of the Site No. 1, rock falls from tuff, similar to the tuff forming the larger rock fall at Site No. 1, damaged outbuildings near three houses. About 500 m³ of debris was shaken from cut slopes 15 m in high beneath which houses and storage buildings were closely juxtaposed (Figure 9.6). Most of the damage was not to the houses proper but to attached storage sheds and outbuildings as shown in Figure 9.7.

9.3.2 Site No. 5

Approximately 3 km east of Atago in Mototetaru, Matsushima, small rock falls occurred in tuff-breccia deposits, damaging several storage buildings adjacent to houses. Failures occurred along a section of cut slope about 100 m in long and produced about 200 m³ of debris. The slope is 10-13 m high and is inclined at about 60°. One rock fall and a scarp exposing tuff breccia is shown in Figure 9.8.

9.3.3 Site No. 6

At Kakinoura in Matsushima, about 100 m³ of blocky debris was produced by a seismic-induced rock fall in tuff that damaged a concrete wall adjacent to a house. This rock fall occurred on the nose of a narrow ridge of about 35 m local relief. The slope failed along pre-existing fractures or joints and produced blocks of debris as long as 1.0 m. The size of the blocks reflects the fracture spacing of the rock. The rock fall and the house adjacent to the damaged concrete wall are shown in Figure 9.9. Two other small rock falls nearby did minor damage to walls of three other houses.

9.3.4 Site No. 7

At Kitashionai, Murata, 25 km southwest of Sendai, another steep slope in tuff failed, generating a small rock fall damaging one house. Figure 9.10 shows several houses near the nearly vertical cut slope about 15 m high. One of these houses suffered damage to a retaining fence and part of the roof. A closeup of the rock fall and roof damage is shown in Figure 9.11.

9.3.5 Site No. 8

A rock fall of approximately 1000 m³ occurred at Hebinumayama, Sanbongi, on a 20 m high, 110 m long, nearly vertical cut-slope no more than 10 m from five houses at the base of the slope (Figure 9.12). The falling rock did minor damage to two houses and attached storage sheds (Figure 9.13). Rock fall occurred along the entire length of the slope which is composed of a bedded tuff containing numerous fractures. Here, as at Kakinoura, failure took place along the pre-existing fracture surfaces. Block size of the debris ranged from several centimeters to several meters.

9.3.6 Site No. 9

A typical roadcut failure (Figure 9.14) was derived from weakly cemented sandstone along a valley west of the Naruse River. The rock fall is less than 1 m thick, and slope height is about 10 m.

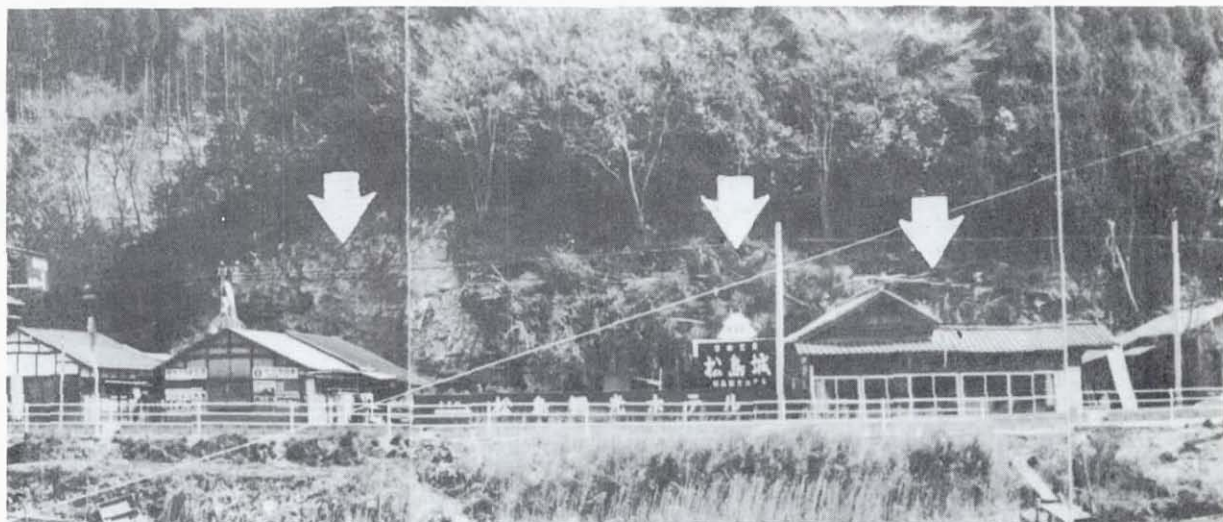

Figure 9.6 Panoramic view of houses damaged by rock fall from adjacent cut slope in tuff*. Rightmost arrow points to area shown in figure 9.7. (Photograph courtesy of Y. Tsuruya).

* Arrows point to failure scarps.

Figure 9.7 Closeup of rock fall and damage to buildings shown in right-hand portion of figure 9.6. (Photograph courtesy of Y. Tsuruya)



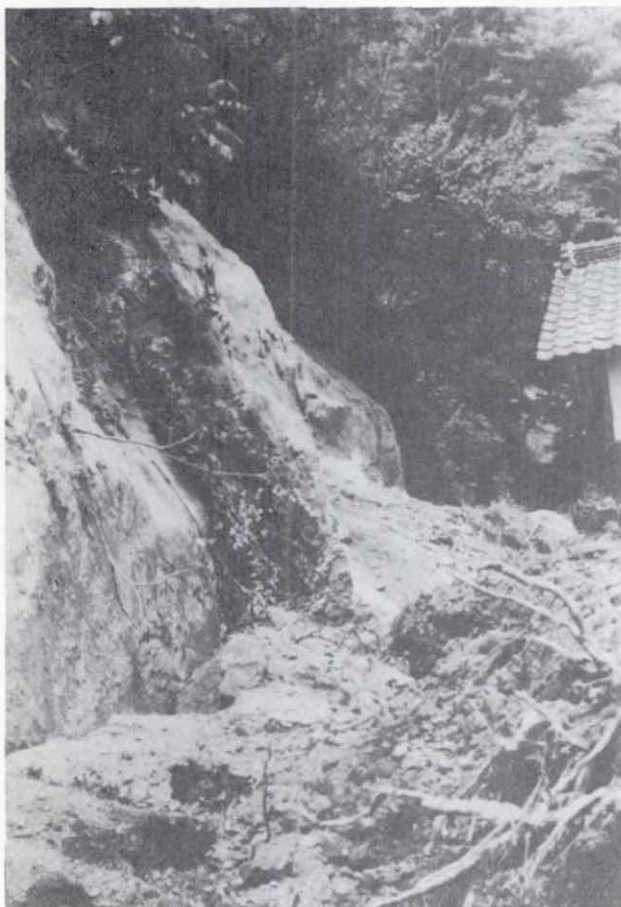

Figure 9.8 Rock fall from steep slope in pumiceous tuff breccia near Mototataru. Failure was about 200 m³ in volume. (Photograph courtesy of Y. Tsuruya)

Figure 9.9 Rock fall in Miocene tuff causing damage to concrete wall adjacent to house. (Photograph courtesy of Y. Tsuruya)



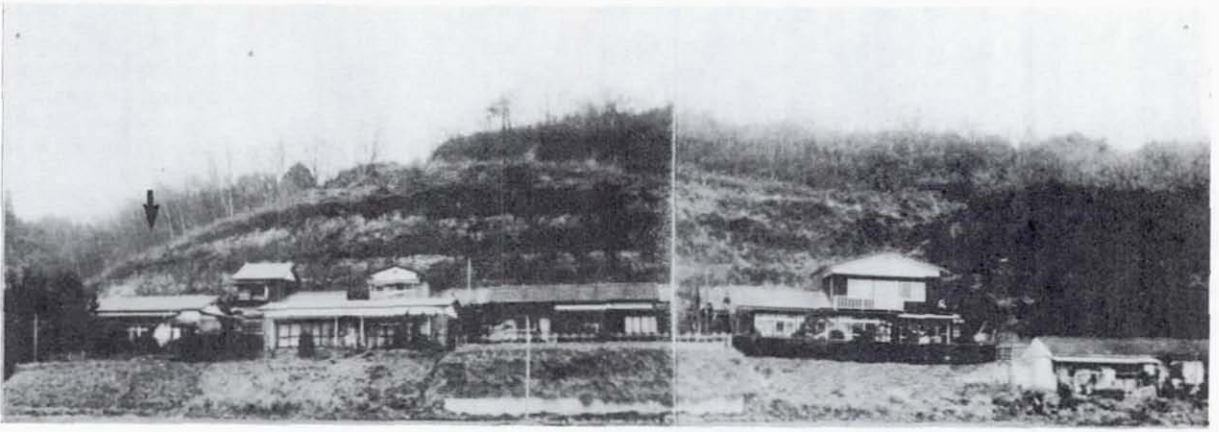
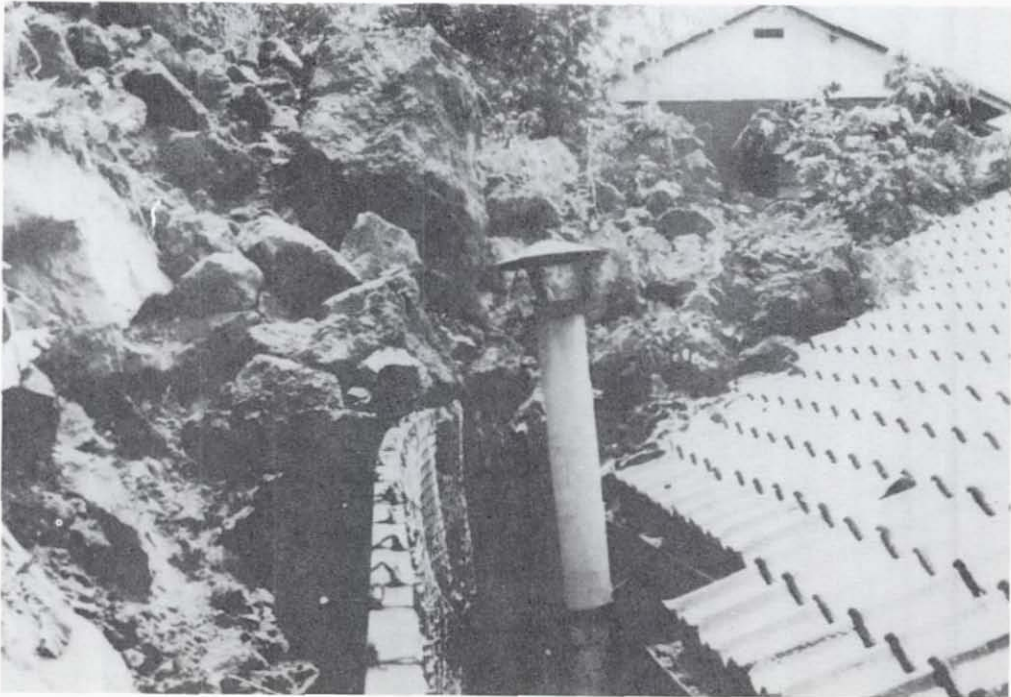

Figure 9.10 Panorama of cut slope near Kitashiona in Miocene tuff which produced rock falls during earthquake damaging nearby houses. Arrow points to damaged house shown in closer view in figure 9.11. (Photograph courtesy of Y. Tsuruya)

Figure 9.11 Rock fall damage to retaining wall and roof of house in left-hand portion (arrow) of figure 9.10. (Photograph courtesy of Y. Tsuruya)



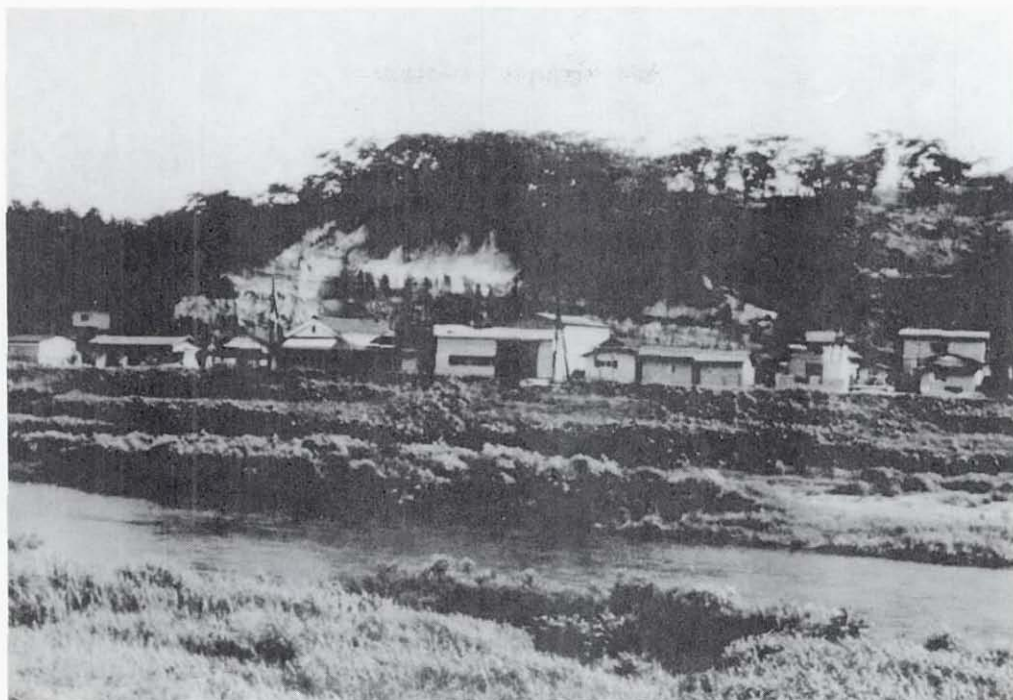

Figure 9.12 Steep slope near Hebinumayama in heavily fractured tuff which underwent failure as rock falls damaging portions of houses in front of the slope.

Figure 9.13 Rock fall from slope shown in figure 9.12 impinging on storage shed next to slope.





Figure 9.14 Rock fall from roadcut in weakly cemented sandstone.

9.3.6 Site No. 10

A rock fall in Triassic slate and fine-grained quartzite occurred on a steep roadcut slope on the north side of the New Kitakami River. The scarp of the rock fall is inclined at about 60° and is formed by prominent slaty cleavage planes (Figure 9.15). The blocky debris broke into pieces of up to 30 cm in longest dimension. Almost all of the debris consisted of blocks that had separated along pre-existing fractures.

9.3.7 Ojika Peninsula

Reconnaissance of the Ojika Peninsula and area immediately to the north was along winding mountain roads that traversed heavily vegetated slopes. The slopes had a thin soil mantle, generally less than 0.5 m thick. Numerous small rock falls were derived from the near vertical roadcuts in these slopes. None contained more than a few cubic meters of debris.

9.4 LANDSLIDES IN ARTIFICIAL FILL

9.4.1 Site No. 11

Several artificial fill failures occurred on roads on the Ojika Peninsula; one such failure is shown in Figure 9.16. The fill material slumped away from beneath the road surface and formed a scarp cutting about 2 m into the highway. The fill appeared to be either uncompacted or poorly compacted sandy clay derived from adjacent bedrock and soil. This failure occurred at a site where rainfall-induced slumping had occurred repeatedly before the earthquake (T. Tazaki, 1978, oral communication). At the time of the visit, plastic sheets had been spread over the extensively cracked pavement to prevent or minimize rainfall infiltration into the scarp area. During observation, heavy rainfall was mobilizing the debris into small mudflows.

9.4.2 Site No. 12

Many slope failures in artificial fill took place within the city limits of Sendai. These failures were mainly slumps. In the neighborhood of Midorigaoka, a large rotational slump occurred in a fill slope of about 15°, composed of gravelly clay. From the headwall scarp to toe, the slump extends approximately 70 m horizontally and 20 m vertically (Y. Matsuzaki, 1978, unpublished data); it is approximately 30 m wide and about 14 m in maximum thickness, thus the approximate volume is 30,000 m³. Most of the slump was above and to the right of one of the 1400 concrete slope-protection dams (sabo works) in Sendai (Figure 9.17). The slump-mass had been covered with nylon tarps before the photograph was taken to prevent infiltration of rainfall.

Many houses had been removed from this slope in previous years due to rainfall-induced slumping; as a result, only one house near the headwall scarp was severely damaged by the seismic-induced sliding. Figure 9.18 shows this house, which was being undercut by the multiple scarps at the head of the slump. The fence in the figure shows the rotational component of slump movement.

About 5 m of horizontal displacement (Y. Matsuzaki, 1978, unpublished data) occurred, placing the toe of the landslide mass only a few meters from houses below. One such house, which had been evacuated because of the threat of recurrent movement is shown in Figure 9.19.

At the time of observation, engineers from the Sabo Section of the Miyagi Prefectural government were engaged in a geotechnical investigation of the slump mass and surrounding area. Boreholes had been drilled in the slide material to establish the depth of the failure surface, to provide samples for strength testing, and to emplace slope inclinometers to monitor any continuing movement. Adjoining areas were also being drilled and monitored to detect any movement that might be precipitated by the slide, such as deformation down-slope from the toe in response to the weight of the encroaching slide mass or retrogressive slumping upslope from the headwall scarp.

Many other artificial fill slopes in Sendai underwent similar failure. At a site about 0.5 km east of Midorigaoka, six houses were condemned by the mayor of Sendai because of cracking



Figure 9.15 Rock fall in roadcut. Note slaty cleavage planes that form the rock fall scarp.

Figure 9.16 Slump in artificial fill along a highway on the Ajika Peninsula.





Figure 9.17 Rotational slump in artificial fill in Sendai (area covered by tarps) which destroyed one house and is threatening others. To left of slump is concrete slope protection dam (sabo works).

Figure 9.18 House near head of slump. House was removed due to undercutting by headwall scarp (Photograph courtesy of Y. Tsuruya).





Figure 9.19 Toe of slump and house below in danger of being overridden by slide mass. House has been evacuated.

beneath and around the houses within the fill area. The decision to destroy the houses was made to protect the houses downslope because the failure of the slope was judged to be imminent unless the weight of the damaged houses was removed (T. Tazaki, 1978, oral communication).

A large, spectacular slump in artificial fill, derived from Miocene ash-flow tuff, occurred in Shiroishi City, about 35 km southwest of Sendai. One fatality occurred from this failure. This slump took place in a planned residential area under conditions of a high water table. The slump movement was accompanied by mudflow (Tohoku Univ. report, 1979). This landslide was not seen by the author, but is described by the Tohoku University report (1979).

Judging from the extensive failure of artificial fill slopes, as compared to the few noticeable landslides on the many steep natural slopes in the same areas, the artificial fill is particularly susceptible to seismic-induced failure. These artificial-fill slopes are likely to be hazards in future earthquakes.

9.5 SUMMARY OF FINDINGS

The June 12, 1978, Miyagi-ken-oki earthquake triggered several thousand landslides in Miyagi and Fukushima Prefectures. A field reconnaissance of the coastal region nearest the epicenter two weeks after the earthquake led to the following general findings:

(1) Most landslides were rock falls and rock slides and occurred on natural and cut slopes steeper than 45° . Damage to houses and other structures was a result of the close proximity of houses to the base of steep slopes.

(2) Many slopes and roadways constructed on artificial fill failed during the earthquake. The slumping of artificial slopes also caused extensive damage to houses. The heaviest damage from these failures occurred in areas occupied by housing developments in Sendai and in Shiroishi.

(3) Many slopes composed of artificial fill were more susceptible to seismic-induced failure than steep natural slopes. This susceptibility is probably a result of insufficient compaction of the fill material. Artificial fill slopes could constitute a significant hazard in future earthquakes.

9.6 REFERENCES

- 9.1. Bonilla, M. C., 1959, Geologic observations in the epicentral area of the San Francisco earthquake of March 22, 1957, in Oakeshott, G. B., ed., The San Francisco earthquake of March 1957: California Division of Mines Special Report No. 57, p. 25-37.
- 9.2. Geologic Map of Miyagi Prefecture, legend in Japanese.
- 9.3. Harp, E. F., Wiczorek, G. F., and Wilson, R. C., 1978, Earthquake-induced landslides from the February 4, 1976 Guatemala earthquake and their implications for landslide hazard reduction: International Symposium on the February 4, 1976 Guatemalan Earthquake and the Reconstruction Process, Guatemala City, Proceedings.
- 9.4. Nason, R. D., 1971, Shattered earth at Wallaby Street, Sylmar, in the San Fernando, California earthquake of February 9, 1971: U.S. Geological Survey Prof. Paper 773, p. 97-98.
- 9.5. Tohoku University Report, 1979, Phenomena and disasters associated with the Miyagi-ken-oki earthquake of 1978 in the East-central part of Northeast Honshu, Japan: Institute of Geology and Paleontology, Tohoku University, no. 80, 97p., 34 figs., 2 tables, 7 pls., (summary and captions in English).

10. GENERAL CONCLUSIONS

The effect of the Miyagi-ken-oki earthquake of June 12, 1978 on the Sendai area was quite moderate, considering its magnitude and the potential for disaster. This was in large measure due to good engineering practice and the extremely quick and comprehensive response of the Japanese authorities to the earthquake. At the time of the team investigation beginning 11 days following the earthquake, much of the debris had been cleared away and repair and recovery operations were well underway. The approaching rainy season gave a sense of urgency to these tasks. With the exception of a few establishments still without city gas service, the situation in Sendai was essentially normal. It was obvious that the response to the earthquake was well planned and that the disaster mitigation and relief activities are well coordinated among the different levels of government. The fact that the main energy release occurred some distance from any inhabited areas lessened the impact that an earthquake of this magnitude otherwise would have had.

Subsequent investigation showed that modern structures and facilities suffered little damage. In particular, structures designed subsequent to the promulgation of the new seismic design provisions of 1971 performed exceedingly well. The successful performance of most modern multistory buildings shows that modern seismic engineering practices can provide resistance to strong earthquake motions at reasonable cost. The total damage due to Miyagi-ken-oki earthquake constituted a small percentage of the total capital investment in buildings and structures, despite recorded ground accelerations in the range 0.25g - 0.40g in the Sendai area, and accelerations as high as 1.0g in upper stories of high rise buildings.

Numerous pockets of damage existed throughout the city that apparently were correlated to the local geology and soil conditions. Acceleration magnitudes across Sendai varied considerably with location. The eastern part of the city, where many of the damaged structures were located, is built on alluvial deposits which, from a foundation standpoint, are poorer than the remaining portion of the city. Soil conditions in the central portion of Sendai are considerably better, and the damage was limited.

Analyses of the earthquake and the performance of structures are currently being conducted or recently have been completed by Japanese engineers and seismologists. One of the first of these is the report on strong motion records and data issued by the Strong Motion Earthquake Observation Council, National Research Center for Disaster Prevention of Japan. Digitization of some of the traces has been performed by the Building Research Institute and Public Works Research Institute. Tokyo Electric Power Company engineers are conducting a comprehensive analysis of the strong motion data gathered at the Fukushima nuclear power plant. When this information is released, probably within the next year or so, it will be of considerable value to engineers and licensing officials in the U.S. as well as Japan. These reactors and containments are similar to those operating in the U.S. and they suffered no damage in the earthquake.

Although similar observations have been made in the aftermath of previous earthquakes, it seems worthwhile to reemphasize the following points about achieving earthquake resistant design:

- (1) Structure should be laid out so that they are as symmetrical as is consistent with their function. Practically all severely damaged or collapsed engineered structures exhibited a significant asymmetry of some kind in the form of an eccentric mass or placement of shear walls.
- (2) When infill panels or spandrels are used, particular attention should be paid to detailing and to the design of structural members connected to them. When used on only one side of a building, their stiffening effect causes most of the damage to occur to that side.
- (3) The apparent correlation of structure damage to local soil and geologic conditions suggests that this factor should receive additional attention in the design of structures of even moderate size and cost. Seismic regulations in codes should include a soils parameter in their load criteria.
- (4) Performance of buildings clearly is related to quality control and design detailing. There were cases of failures where column ties appeared to be minimal and improperly

anchored. In other instances, they appeared to be adequate. The question arises whether discrepancies exist between the structure as built and the code recommendations.

- (5) Post earthquake investigation of damaged bridges has taught many lessons. The 1964 Niigata and 1971 San Fernando earthquakes pointed to the importance of providing 1) restraining devices across hinges and joints and 2) proper column reinforcement details including the foundation connections. The 1976 Guatemala earthquake demonstrated that the longitudinal restraining devices across hinges can provide the continuity required to keep spans from falling. The Miyagi-ken-oki earthquake has provided incentive to further investigate the need for and performance of transverse restraining devices and to examine the philosophy behind ductile and non-ductile column/pier design. Another topic of interest is correlation of soil type to foundation/substructure damage.
- (6) The collapse of the Kin-noh bridge, which was previously damaged in a February 1978 earthquake, indicates that structural damage may occur due to either strong aftershocks or multiple event excitation.

In regions of high seismicity, critical and important structures should be identified and additional care should be taken in detail design and in field inspection (quality assurance) during construction.

U.S. DEPT. OF COMM. BIBLIOGRAPHIC DATA SHEET	1. PUBLICATION OR REPORT NO. NBS SP 592	2. Gov't. Accession No.	3. Recipient's Accession No.
4. TITLE AND SUBTITLE An Investigation of the Miyagi-ken-oki, Japan Earthquake of June 12, 1978		5. Publication Date October 1980	6. Performing Organization Code
7. AUTHOR(S) Bruce R. Ellingwood	8. Performing Organ. Report No.		
9. PERFORMING ORGANIZATION NAME AND ADDRESS NATIONAL BUREAU OF STANDARDS DEPARTMENT OF COMMERCE WASHINGTON, DC 20234		10. Project/Task/Work Unit No.	11. Contract/Grant No.
12. SPONSORING ORGANIZATION NAME AND COMPLETE ADDRESS (Street, City, State, ZIP) Same as item 9.		13. Type of Report & Period Covered Final	14. Sponsoring Agency Code
15. SUPPLEMENTARY NOTES Library of Congress Catalog Card Number: 80-600116 <input type="checkbox"/> Document describes a computer program; SF-185, FIPS Software Summary, is attached.			
16. ABSTRACT (A 200-word or less factual summary of most significant information. If document includes a significant bibliography or literature survey, mention it here.) On June 12, 1978, a destructive earthquake with Richter magnitude of 7.4 occurred off the east coast of Miyagi Prefecture, Japan. Preliminary estimates by the National Land Agency of Japan indicated that the earthquake caused an equivalent of \$800 million in total damage. There is a cooperative agreement between the Governments of the United States and Japan termed the U.S.-Japan Program in Natural Resources (UJNR). Following the earthquake, it was arranged through UJNR that teams of U.S. structural engineers and geologists would visit Miyagi Prefecture and inspect the damage caused by the earthquake. This report assembles the information and collective experiences of the investigation team so as to describe the earthquake and document its effects. Field investigations conducted by geologists and structural engineers are described in detail and some of the implications for seismic resistant design and construction of structures in the United States are also discussed.			
17. KEY WORDS (six to twelve entries; alphabetical order; capitalize only the first letter of the first key word unless a proper name; separated by semicolons) Bridges; buildings; dikes; earthquakes; foreign engineering; geology; highways; housing; landslides; liquefaction; power plants; railroads; rock slides; seismicity; structural engineering.			
18. AVAILABILITY <input checked="" type="checkbox"/> Unlimited <input type="checkbox"/> For Official Distribution. Do Not Release to NTIS <input checked="" type="checkbox"/> Order From Sup. of Doc., U.S. Government Printing Office, Washington, DC 20402. <input type="checkbox"/> Order From National Technical Information Service (NTIS), Springfield, VA. 22161		19. SECURITY CLASS (THIS REPORT) UNCLASSIFIED	21. NO. OF PRINTED PAGES 232
		20. SECURITY CLASS (THIS PAGE) UNCLASSIFIED	22. Price

NBS TECHNICAL PUBLICATIONS

PERIODICALS

JOURNAL OF RESEARCH—The Journal of Research of the National Bureau of Standards reports NBS research and development in those disciplines of the physical and engineering sciences in which the Bureau is active. These include physics, chemistry, engineering, mathematics, and computer sciences. Papers cover a broad range of subjects, with major emphasis on measurement methodology and the basic technology underlying standardization. Also included from time to time are survey articles on topics closely related to the Bureau's technical and scientific programs. As a special service to subscribers each issue contains complete citations to all recent Bureau publications in both NBS and non-NBS media. Issued six times a year. Annual subscription: domestic \$13; foreign \$16.25. Single copy, \$3 domestic; \$3.75 foreign.

NOTE: The Journal was formerly published in two sections: Section A "Physics and Chemistry" and Section B "Mathematical Sciences."

DIMENSIONS/NBS—This monthly magazine is published to inform scientists, engineers, business and industry leaders, teachers, students, and consumers of the latest advances in science and technology, with primary emphasis on work at NBS. The magazine highlights and reviews such issues as energy research, fire protection, building technology, metric conversion, pollution abatement, health and safety, and consumer product performance. In addition, it reports the results of Bureau programs in measurement standards and techniques, properties of matter and materials, engineering standards and services, instrumentation, and automatic data processing. Annual subscription: domestic \$11; foreign \$13.75.

NONPERIODICALS

Monographs—Major contributions to the technical literature on various subjects related to the Bureau's scientific and technical activities.

Handbooks—Recommended codes of engineering and industrial practice (including safety codes) developed in cooperation with interested industries, professional organizations, and regulatory bodies.

Special Publications—Include proceedings of conferences sponsored by NBS, NBS annual reports, and other special publications appropriate to this grouping such as wall charts, pocket cards, and bibliographies.

Applied Mathematics Series—Mathematical tables, manuals, and studies of special interest to physicists, engineers, chemists, biologists, mathematicians, computer programmers, and others engaged in scientific and technical work.

National Standard Reference Data Series—Provides quantitative data on the physical and chemical properties of materials, compiled from the world's literature and critically evaluated. Developed under a worldwide program coordinated by NBS under the authority of the National Standard Data Act (Public Law 90-396).

NOTE: The principal publication outlet for the foregoing data is the Journal of Physical and Chemical Reference Data (JPCRD) published quarterly for NBS by the American Chemical Society (ACS) and the American Institute of Physics (AIP). Subscriptions, reprints, and supplements available from ACS, 1155 Sixteenth St., NW, Washington, DC 20056.

Building Science Series—Disseminates technical information developed at the Bureau on building materials, components, systems, and whole structures. The series presents research results, test methods, and performance criteria related to the structural and environmental functions and the durability and safety characteristics of building elements and systems.

Technical Notes—Studies or reports which are complete in themselves but restrictive in their treatment of a subject. Analogous to monographs but not so comprehensive in scope or definitive in treatment of the subject area. Often serve as a vehicle for final reports of work performed at NBS under the sponsorship of other government agencies.

Voluntary Product Standards—Developed under procedures published by the Department of Commerce in Part 10, Title 15, of the Code of Federal Regulations. The standards establish nationally recognized requirements for products, and provide all concerned interests with a basis for common understanding of the characteristics of the products. NBS administers this program as a supplement to the activities of the private sector standardizing organizations.

Consumer Information Series—Practical information, based on NBS research and experience, covering areas of interest to the consumer. Easily understandable language and illustrations provide useful background knowledge for shopping in today's technological marketplace.

Order the above NBS publications from: Superintendent of Documents, Government Printing Office, Washington, DC 20402.

Order the following NBS publications—FIPS and NBSIR's—from the National Technical Information Services, Springfield, VA 22161.

Federal Information Processing Standards Publications (FIPS PUB)—Publications in this series collectively constitute the Federal Information Processing Standards Register. The Register serves as the official source of information in the Federal Government regarding standards issued by NBS pursuant to the Federal Property and Administrative Services Act of 1949 as amended, Public Law 89-306 (79 Stat. 1127), and as implemented by Executive Order 11717 (38 FR 12315, dated May 11, 1973) and Part 6 of Title 15 CFR (Code of Federal Regulations).

NBS Interagency Reports (NBSIR)—A special series of interim or final reports on work performed by NBS for outside sponsors (both government and non-government). In general, initial distribution is handled by the sponsor; public distribution is by the National Technical Information Services, Springfield, VA 22161, in paper copy or microfiche form.

BIBLIOGRAPHIC SUBSCRIPTION SERVICES

The following current-awareness and literature-survey bibliographies are issued periodically by the Bureau:

Cryogenic Data Center Current Awareness Service. A literature survey issued biweekly. Annual subscription: domestic \$35; foreign \$45.

Liquefied Natural Gas. A literature survey issued quarterly. Annual subscription: \$30.

Superconducting Devices and Materials. A literature survey issued quarterly. Annual subscription: \$45. Please send subscription orders and remittances for the preceding bibliographic services to the National Bureau of Standards, Cryogenic Data Center (736) Boulder, CO 80303.

