

PB96-154836



NISTIR 5765

Simplified Design Procedure for Hybrid Precast Concrete Connections

Geraldine S. Cheok
William C. Stone
Suzanne D. Nakaki

February 1996
Building and Fire Research Laboratory
National Institute of Standards and Technology
Gaithersburg, MD 20899



REPRODUCED BY
U.S. DEPARTMENT OF COMMERCE
NATIONAL TECHNICAL
INFORMATION SERVICE
SPRINGFIELD, VA 22161

U.S. Department of Commerce
Ronald H. Brown, *Secretary*
Technology Administration
Mary L. Good, *Under Secretary for Technology*
National Institute of Standards and Technology
Arati Prabhakar, *Director*

PROTECTED UNDER INTERNATIONAL COPYRIGHT
ALL RIGHTS RESERVED.
NATIONAL TECHNICAL INFORMATION SERVICE
U.S. DEPARTMENT OF COMMERCE

DISCLAIMER

The proposed design procedure is based on a limited number of experimental tests. Within the bounds of the material properties, geometry, and loads associated with those tests, the design procedures described herein are believed to be conservative. The National Institute of Standards and Technology does not however, warranty, either expressly or implied, that these design procedures are applicable outside the range of those experimental variables.

Certain trade names and company products are mentioned in the text or identified in an illustration in order to adequately specify the experimental procedure and equipment used. In no case does such an identification imply recommendation or endorsement by the National Institute of Standards and Technology, nor does it imply that the products are necessarily the best available for the purpose.

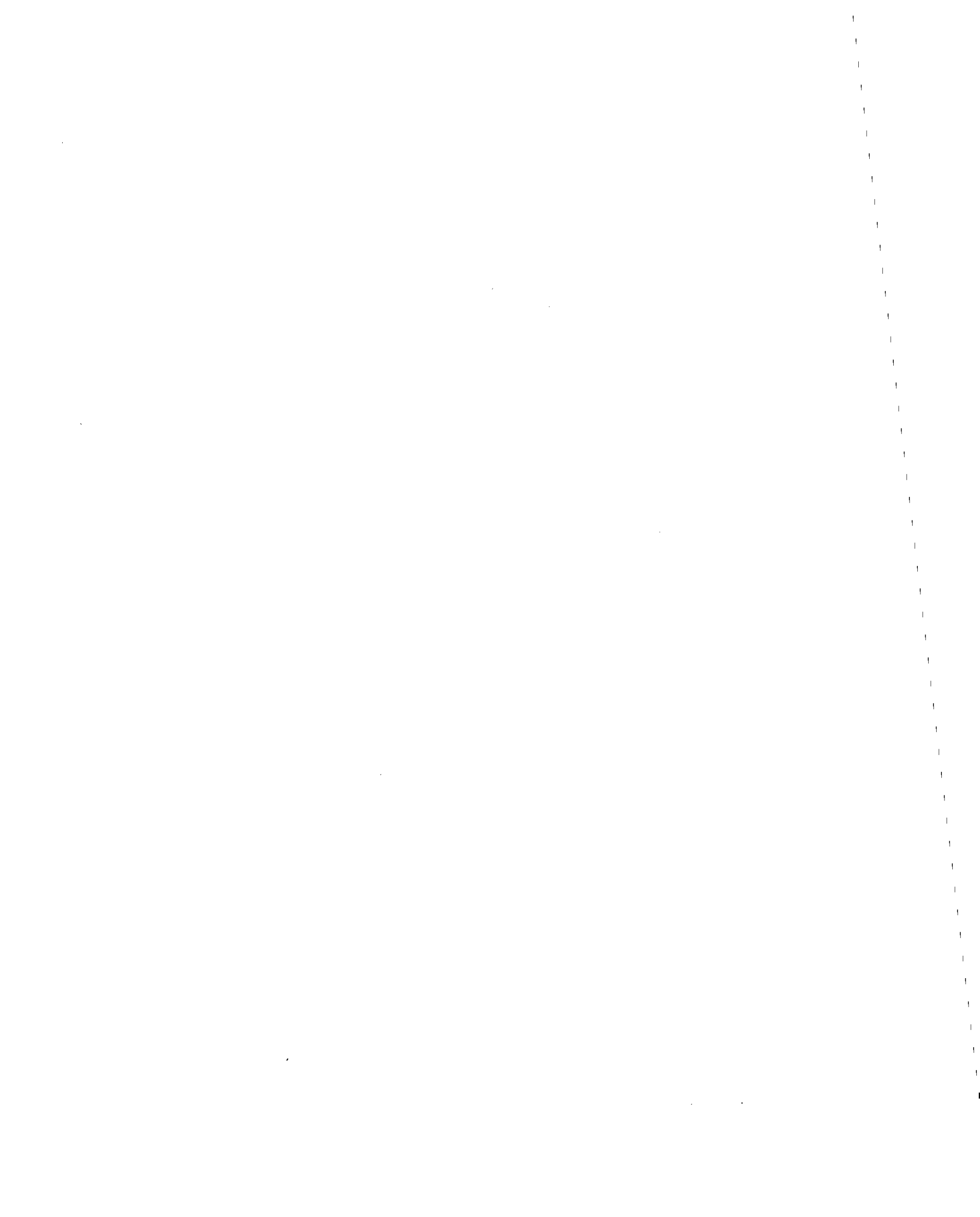

ABSTRACT

A rational design procedure is presented to compute the probable moment, the nominal moment, and the story drift capacities of a hybrid precast moment-resisting beam-to-column connection. The hybrid connections consist of mild steel which is used to dissipate energy by yielding and high strength prestressing steel which is used to provide the shear resistance through friction developed at the beam-column interface by the post-tensioning force. The design procedure is based on three 1/3-scale hybrid precast beam-to-column connections tested at the National Institute of Standards and Technology (NIST). The simplified procedure relies on the stress-strain behavior of mild steel up to its ultimate strength and is based on equilibrium equations at the beam-column joint. The appendices include a commentary of the design procedure, proposed evaluation criterion for this hybrid connection, sample calculations using the design procedure, and other calculations used to develop the design criterion.

KEYWORDS: Building technology, beam-column, concrete, connection, joint, drift capacity, moment capacity, precast, post-tensioning, seismic design procedure.



TABLE OF CONTENTS

ABSTRACT	iii
TABLE OF CONTENTS	v
LIST OF TABLES	ix
LIST OF FIGURES	xi
NOTATION AND SYMBOLS	xiii
1.0 INTRODUCTION	1
2.0 DESIGN CONCEPT	1
3.0 CONSTRUCTION SEQUENCE	2
4.0 DESIGN FORCES	3
4.1 Serviceability	3
4.1.1 UBC Drift Criteria	3
4.1.2 System Stiffness	3
4.2 Strength	3
4.2.1 Strength Reduction Factors	3
4.2.2 Base Shear	3
4.2.3 Load Combinations	3
4.2.4 Other Model Codes	4
4.3 Maximum Drift Demand	4
5.0 VERTICAL SHEAR RESISTANCE	4
5.1 General	4
5.2 Minimum Clamping Force	5
5.3 Span-to-Depth Ratio	5
5.4 Corbels	6
6.0 MINIMUM AND MAXIMUM PRESTRESS	6
6.1 Strand Stresses	6
6.2 Concrete Stresses	6
7.0 PROBABLE MOMENT CAPACITY	6
7.1 Limit State Description	6
7.2 Energy Dissipation	7
7.3 Calculation Procedure	7
7.3.1 Assumptions	7
7.3.3 Procedure	8
7.4 Maximum Drift Capacity	10
8.0 NOMINAL MOMENT CAPACITY	11
8.1 GENERAL	11
8.2 Calculation Procedure	11
9.0 BEAM AND COLUMN DESIGN	12
9.2 Beam Design	12
9.3 Column Design	12

10.0	DETAILING REQUIREMENTS	13
10.1	Slab Interaction	13
10.2	Unbonded Post-tensioning	13
10.3	Unbonded Mild Steel Reinforcing	13
10.4	Concrete Confinement	13
	ACKNOWLEDGEMENTS	14
	REFERENCES	14
	SUMMARIES OF APPENDICES	19
	APPENDIX A: COMMENTARY	21
C1.0	INTRODUCTION	21
C3.0	CONSTRUCTION SEQUENCE	21
C4.0	DESIGN FORCES	21
	C4.1.2 Load Combinations	22
	C4.3 Maximum Drift Demand	22
C5.0	VERTICAL SHEAR RESISTANCE	23
	C5.1 General	23
	C5.2 Minimum Clamping Force	23
	C5.3 Span-to-Depth Ratio	23
	C5.4 Corbels	24
C6.0	MINIMUM AND MAXIMUM PRESTRESS	25
	C6.1 Strand Stresses	25
	C6.2 Concrete Stresses	25
C7.0	PROBABLE MOMENT CAPACITY	25
	C7.3.3 Procedure	25
	C7.4 Maximum Drift Capacity	27
	C7.4.1 Computation of Maximum Drift Capacity	27
C8.0	NOMINAL MOMENT CAPACITY	28
	C8.2 Calculation Procedure	28
C9.0	BEAM AND COLUMN DESIGN	28
	C9.2 Beam Design	28
C10.0	DETAILING REQUIREMENTS	29
	C10.1 Slab Interaction	29
	C10.4 Concrete Confinement	29
	APPENDIX B: PROPOSED ICBO ACCEPTANCE CRITERIA	41
	APPENDIX C: TYPICAL STRESS-STRAIN CURVES FOR STEEL	45
	APPENDIX D: SAMPLE CALCULATIONS FOR NIST SPECIMENS	47
	APPENDIX E: CALCULATIONS TO ESTIMATE ADDITIONAL DEBONDED LENGTH OF MILD STEEL BARS	69
	APPENDIX F: DETERMINATION OF M_s/M_{pr} RATIO AT MAXIMUM A_s	71

LIST OF TABLES

Table A1. Earthquake Records.	30
Table D1. Probable Moments	65
Table D2. Comparison of M_n , M_y and M_{pr}	66

LIST OF FIGURES

Figure 1. Precast Hybrid Moment Connection	15
Figure 2. Drift Demand for UBC Soil Type 1.	16
Figure 3. Drift Demand for UBC Soil Type 2.	16
Figure 4. Drift Demand for UBC Soil Type 3.	17
Figure 5. Rotation at the Beam-Column Joint	17
Figure A1a. Drift Demand for UBC Soil Type 1, T = 0.5 s.	31
Figure A1b. Drift Demand for UBC Soil Type 2, T = 0.5 s.	31
Figure A1c. Drift Demand for UBC Soil Type 3, T = 0.5 s.	32
Figure A2a. Drift Demand for UBC Soil Type 1, T = 1.0 s.	32
Figure A2b. Drift Demand for UBC Soil Type 2, T = 1.0 s.	33
Figure A2c. Drift Demand for UBC Soil Type 3, T = 1.0 s.	33
Figure A3a. Drift Demand for UBC Soil Type 1, T = 1.6 s.	34
Figure A3b. Drift Demand for UBC Soil Type 2, T = 1.6 s.	34
Figure A3c. Drift Demand for UBC Soil Type 3, T = 1.6 s.	35
Figure A4a. Drift Demand for UBC Soil Type 1, T = 3.4 s.	35
Figure A4b. Drift Demand for UBC Soil Type 2, T = 3.4 s.	36
Figure A4c. Drift Demand for UBC Soil Type 3, T = 3.4 s.	36
Figure A6. Comparison of Rotation (θ) at the Beam-Column Joint to Connection Rotation, M-P-Z4	37
Figure A7. Comparison of Rotation (θ) at the Beam-Column Joint to Connection Rotation, N-P-Z4	38
Figure A8. Comparison of Rotation (θ) at the Beam-Column Joint to Connection Rotation, O-P-Z4	38
Figure A9. Comparison of Rotation (θ) at the Beam-Column Joint to Connection Rotation, P-P-Z4	39
Figure D1. Load Displacement Plot for Specimen M-P-Z4	67

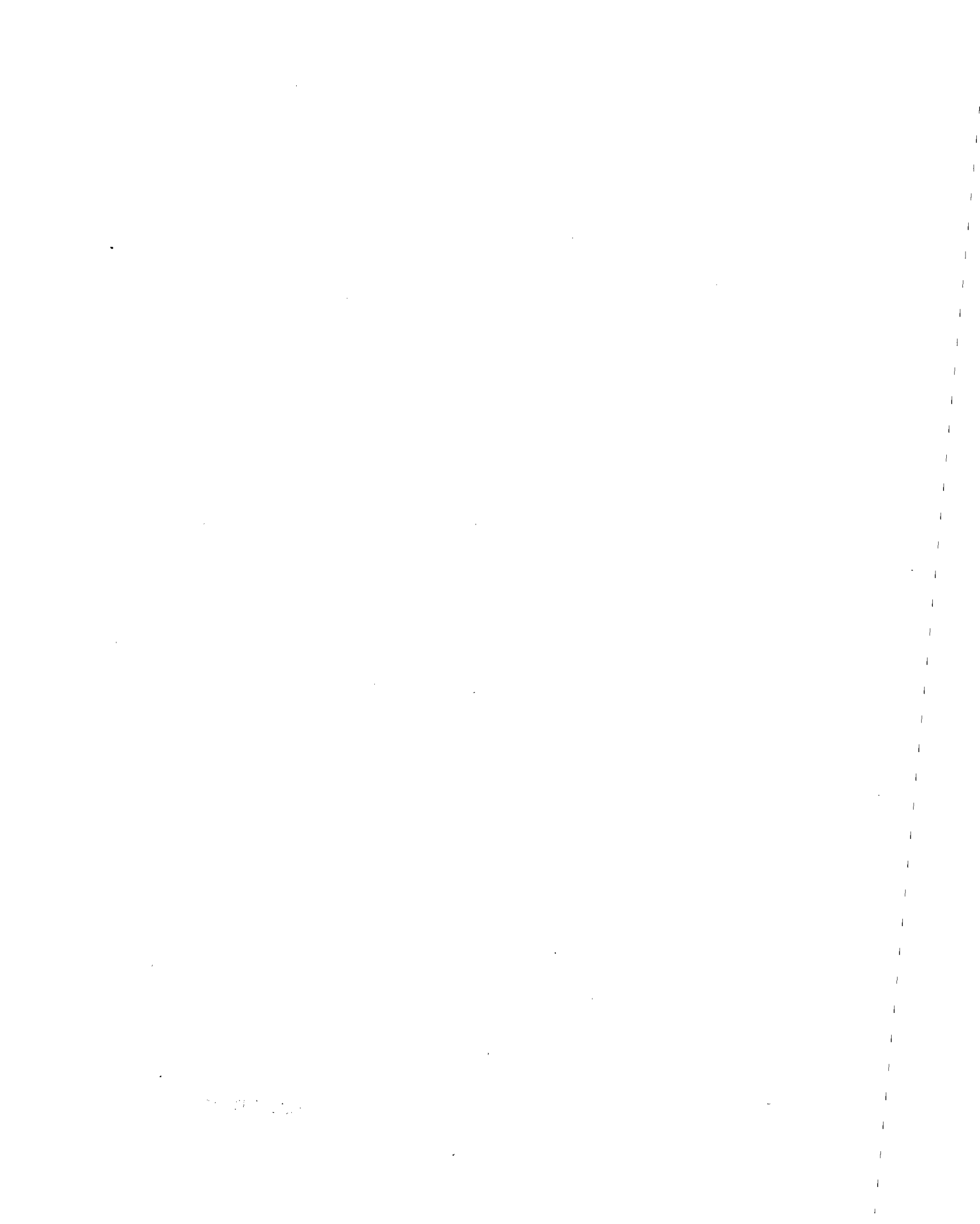

NOTATION AND SYMBOLS

a	= Equivalent stress block depth, $\beta_1 c$.
A_{ps}	= Area of PT steel.
A_s	= Area of mild tension steel.
A'_s	= Area of mild compression steel.
b	= Beam width.
C	= Total compression force.
C_c	= Concrete compression force.
C_s	= Compressive force contribution from the mild compressive steel.
c	= Depth from the extreme compression fiber to the neutral axis.
d	= Effective depth.
d_b	= Diameter of reinforcing bar.
f_{ps}	= Stress in PT steel.
f_{pu}	= Ultimate tensile strength of PT steel.
f_u	= Ultimate tensile strength of mild steel. 105 ksi for a typical Grade 60 reinforcing bar (Appendix C).
f_y	= Yield strength of mild steel.
F_p	= Post-tensioning force.
h	= Overall member thickness.
h_c	= Overall thickness of column.
L_{clear}	= Beam clear span.
L_u	= <i>Intentional</i> unbonded length of mild steel.
$L_{u, ps}$	= Unbonded length of the PT steel.
M	= Moment demand at the beam end.
M_D	= Moment due to dead load.
M_E	= Moment due to earthquake load.
M_L	= Moment due to live load.
M_n	= Nominal moment capacity.
M_{pr}	= Probable moment capacity of beam = $M_s + M_{ps}$.
$M_{pr1, pr2}$	= Probable beam end moments as determined in Section 7.
M_{ps}	= Beam moment capacity contributed by post-tensioned steel.
M_s	= Beam moment capacity contributed by mild steel.
T_{ps}	= Tension force in PT steel.
T_s	= Tension force in mild tension steel.
V_c	= Nominal shear strength provided by the concrete.
V_D	= Unfactored shear force due to dead load.
V_{D+L}	= Shear due to unfactored dead plus live load.
V_e	= Design shear forces caused by seismic loading determined from UBC Section 1921.3.4.1 (ACI 21.3.4.1).
V_L	= Unfactored shear force due to live load.
V_n	= Nominal shear strength.
V_s	= Nominal shear strength provided by the transverse reinforcement.
V_u	= Required shear strength.
w_D	= Dead load per unit length or per unit area.
w_L	= Live load per unit length or per unit area.
β_1	= Factor defined in UBC Section 1910.2.7.3 (ACI 10.2.7.3).
Δ_{ps}	= Elongation of the PT steel.
Δ_s	= Elongation of the mild steel.
ϵ_{sh}	= Strain at onset of strain hardening of mild steel.

ϵ_{ps}	=	Strain in the PT steel.
$\epsilon_{ps,ini}$	=	Initial strain in the PT steel after losses due to post-tensioning force.
ϵ_u	=	Mild steel strain at ultimate stress, f_u .
γ	=	Ratio of d/h.
ϕ	=	Strength reduction factor.
μ	=	Coefficient of friction.

1.0 INTRODUCTION

Current building codes (such as the American Concrete Institute and Uniform Building Codes) used in high seismic areas of the United States have evolved toward sets of prescriptive rules which codify design guidelines for a few building systems. Seismic resistant reinforced concrete systems have, in effect, been limited to cast-in-place shear walls and special moment resisting frames (SMRF). While these two systems have been shown to perform well during earthquakes, implementation into a prefabricated building of the details prescribed for them is difficult.

The current UBC code [UBC, 1994] allows alternative seismic systems to be used if the following requirements are met:

"1627.9.2 **Undefined structural systems.** Undefined structural systems shall be shown by technical and test data which establish the dynamic characteristics and demonstrate the lateral-force resistance and energy absorption capacity to be equivalent to systems listed in Table 16-N for equivalent R_w values."

The precast moment frame using hybrid connections, shown in Figure 1, was developed to meet the requirements of an $R_w = 12$ system. The connection consists of mild steel [$f_y = 414$ MPa (60 ksi)] located at the top and bottom of the beam and high strength prestressing steel [$f_{pu} = 1862$ MPa (270 ksi)] located at mid-depth of the beam. The mild steel is used to dissipate energy by yielding, and the prestressing steel is used to provide the shear resistance from the friction developed by the post-tensioning (PT) force. The mild steel is fully bonded except for a very short length and the PT steel is unbonded or partially debonded. The purpose of the short unbonded length of the mild steel is to delay fracture of the mild steel bars and the unbonding of the PT steel is intended to delay yielding of the PT steel. The term hybrid refers to the simultaneous use of two types of steel with different roles.

This report describes design procedures for the hybrid connections that ensure that both the required strength and story drift capacities are achieved. In addition, specific detailing requirements which must be followed for the same purpose are described.

2.0 DESIGN CONCEPT

The precast moment frame using the hybrid connection is based upon the following:

1. Multi-story columns are used with single bay beams requiring a connection at the beam column interface, which is also the location of maximum seismic moment.
2. A ductile connection is developed at the beam-column interfaces, causing all yielding at this location and minimal damage to the precast beams.
3. Post-tensioned reinforcement is used to provide a reliable clamping force at the beam-column interface to resist gravity loads.

4. Vertical shear resistance at the beam-column interface is provided by friction created by a combination of the PT clamping force and the compression portion of the moment couple.
5. At the required maximum drift, the PT steel remains elastic.
6. The concrete in the end regions of the beam is confined so that it will not spall at the required maximum drift.
7. Mild steel reinforcement provides a portion of the flexural strength in addition to providing energy dissipation.
8. Sufficient mild steel reinforcement is provided to resist the gravity loads on the beam in the unlikely event of strand anchorage failure. This is provided as a backup collapse prevention mechanism.

3.0 CONSTRUCTION SEQUENCE

Construction of the precast moment frame using hybrid connections must proceed following the steps described below*:

1. Erect columns with temporary supports for the beams.
2. Erect beams, placing them on the temporary supports.
3. Push the mild steel bars through the column and beams.
4. Feed PT strands through the duct located at the center of the beam.
5. Grout the joint at the beam column interface using fiber reinforced grout. A non-shrink grout which has strength equal to $1.2 f'_c$ [†] should be used when f'_c is the compressive strength of the concrete.
6. After the grout has cured to a minimum strength of 20.7 MPa (3000 psi), stress the strands so that the stress after losses does not exceed the specified initial prestress.
7. Grout the mild steel bars full length (unbonded length is provided by wrapping the required portion of the bar with plastic material).
8. Remove temporary support angles.

The PT steel is bonded at mid-span of the beams and unbonded through the column and for a specified distance on either side of the column face (Figure 1). In this scheme, the bonded length is equal to the minimum required for the development length and the unbonded length is the remaining length equal to 0.5 times the difference of the span length, the development length,

*More detailed description of the construction process and fabrication requirements are contained in the QA/QC manual, Morgan, J. and Seagren D. (1994), "Precast Hybrid Moment Frame Quality Control Procedures," Charles Pankow Builders, Ltd., Altadena, CA, Nov.

[†]A factor of 1.2 used because the strength of the grout is determined from tests of cubes whereas the strength of the concrete is determined from tests of cylinders. This factor accounts for the effects of the different shape of the specimens.

and the column width. The unbonded length must be checked to see if it is sufficient to ensure that the PT steel remains elastic at maximum drift capacity. This bonding scheme provides a second anchorage system for the PT steel in addition to the required mechanical anchors. However, totally unbonded PT steel may also be used.

4.0 DESIGN FORCES

4.1 Serviceability

4.1.1 UBC Drift Criteria

The drift requirements of UBC Section 1628.8.2 are followed.

4.1.2 System Stiffness

In a prestressed system, prior to decompression (zero tension stress in concrete), the system will behave in a manner comparable to a cast-in-place system, except that the beams are not likely to crack. Gross section properties should be used to develop a representation of system stiffness. For the interval between decompression and yield, the section properties are between that of an uncracked section and a cracked section.

4.2 Strength

4.2.1 Strength Reduction Factors

Strength reduction factors per Chapter 19 of the UBC shall be used.

4.2.2 Base Shear

The design base shear shall be calculated as per UBC Section 1628.2. An R_w of 12 shall be used in the calculation of the design base shear.

In the calculation of the period, UBC Section 1628.2.2 1 Method A, the value of C_1 shall be equal to 0.030 for reinforced concrete moment-resisting frames.

4.2.3 Load Combinations

Three load combinations are considered.

$$\phi M_n \geq 1.4 M_D + 1.7 M_L \dots \dots \dots (1)$$

$$\phi M_n \geq 1.4 (M_D + M_L + M_E) \dots \dots \dots (2)$$

$$\phi M_n \geq 0.9 M_D \pm 1.4 M_E \dots \dots \dots (3)$$

If the precast moment frame using hybrid connections is used to resist wind loads, UBC load combinations shall be used.

4.2.4 Other Model Codes

This system concept can be used in conjunction with other model or local building codes, with appropriate design forces, strength reduction factors and load factors to achieve the same design objectives.

4.3 Maximum Drift Demand

The drift demand as used in this section differs from the UBC drift requirement (Section 4.1.1) both in purpose and calculation. The UBC drift requirement is a serviceability requirement and is based on drifts of an elastic structure subjected to UBC design forces. The proposed drift demands are estimates of real story drifts that a structure may undergo in an earthquake. They were computed from non-linear time history analyses of models subjected to a suite of acceleration records obtain from past earthquakes.

Drift demands calculated from the non-linear time history analyses are shown in Figures 2-4. Based on the dynamic analyses (Figures 2-4) the story drift demands are recommended:

1. 1.5% for UBC soil type 1
2. 3.5% for UBC soil type 2
3. 4.0% for UBC soil type 3

In lieu of the proposed drift demands, inelastic dynamic analyses using a site specific response spectrum may be used to determine the required drift demand.

5.0 VERTICAL SHEAR RESISTANCE

5.1 General

Vertical shear resistance at the column interface is provided by two mechanisms:

- Friction created by the clamping force provided by the PT.
- Friction created by the compression portion of the moment couple induced by gravity, wind, or seismic moments at the beam column interface.

The shear demand at the beam column interface is a function of both the applied gravity loads and the induced seismic moments which are limited to the probable moment capacity of the connection.

$$V_u \leq \phi V_n \dots\dots\dots (4)$$

$$V_u \leq 1.4 V_D + 1.7 V_L + \frac{M_{p1} + M_{p2}}{L_{clear}} \dots\dots\dots (5)$$

The frictional shear resistance is provided at the interface by the two mechanisms described above.

$$V_n = \mu (F_p + C) \dots\dots\dots (6)$$

where μ is defined in UBC Section 1911.7.4.3 (ACI 11.7.4.3) and depends on the surface characteristics of the beam and column at the interface. A roughened surface [6 mm (0.25 in.)] per UBC 1911.7.9 (ACI 11.7.9) is recommended for this connection ($\mu = 1.0$).

5.2 Minimum Clamping Force

Using Eqs. 4, 5, and 6, the minimum required clamping force, after losses, F_p , is

$$\begin{aligned} \phi \mu F_p &= 1.4 V_D + 1.7 V_L \\ F_p &= \frac{1.4 V_D + 1.7 V_L}{\phi \mu} \dots\dots\dots (7) \end{aligned}$$

Losses as defined in ACI 318-95, Section 18.6.1 should be considered, and calculations of such losses should be based on procedures or formulae recommended/approved by the local building codes.

5.3 Span-to-Depth Ratio

To ensure that no slip occurs between the beam and column, the minimum clear span to overall thickness of member, L/h , ratio shall be

$$\frac{L_{clear}}{h} \geq \frac{1}{\phi \mu} \dots\dots\dots (8)$$

for $\gamma = d/h$,

$$\frac{L_{clear}}{d} \geq \frac{1}{\phi \mu \gamma} \dots \dots \dots (9)$$

but not less than the required clear span to effective depth, L/d, ratio of 4 [UBC 1921.3.1.2 (ACI 21.3.1.2)]

5.4 Corbels

Since there was no vertical slip during the tests of the connections [Stone et. al., 1994], corbels that resist only vertical loads would not adversely affect the performance of the connection. However, the rotation at the interface is significant and if permanent corbels are used, their design must allow for this rotation.

6.0 MINIMUM AND MAXIMUM PRESTRESS

6.1 Strand Stresses

The maximum stress in the PT steel must be limited to ensure that no yielding of the PT steel occurs at maximum drift capacity. Yielding of the PT steel is to be prevented to safeguard against loss of the clamping force during load reversal. Limiting the initial prestress allows for greater strain capacity in the PT steel to accommodate the large story drift demands expected in a major earthquake.

6.2 Concrete Stresses

The maximum limit on the concrete prestress is controlled by concrete strength and by the provided confinement in the compression zones.

7.0 PROBABLE MOMENT CAPACITY

7.1 Limit State Description

The proposed calculation procedure is intended to ensure that the hybrid connection is able to accommodate the story drift demands (See Section 4.3) while retaining at least 80% of its maximum capacity.

The performance requirement for the connection are as follows:

- The PT steel must not yield.
- The mild steel may yield but must not fracture before reaching the required the drift demand.
- The compression region of the beam must be able to sustain large strains without degradation of its load carrying capacity.

These requirements are satisfied by limiting the initial stress in the PT steel, providing sufficient unbonded length of both PT and mild steels, and developing appropriate confinement details for the concrete compression zone.

7.2 Energy Dissipation

As currently required by the UBC, the energy absorption capacity of new moment resisting systems should be equivalent to that of a conventional cast-in-place system. However, recent studies [Stone et. al, (in progress), Priestley and Tao (1993)] have shown that at high drift levels, the benefit of additional energy dissipation is unclear and that system performance at high drift levels may be more dependent on the input ground motion than on the energy dissipation capacity. Therefore, while some energy dissipation is necessary for deflection control, the drift capacity (Section 7.4) is a more appropriate performance requirement.

7.3 Calculation Procedure

7.3.1 Assumptions

1. The Whitney stress block is used for calculation of the concrete compression force.
2. The post-tensioning (PT) steel is located at mid-depth of the beam.
3. The mild steel debonds over a distance equal to $2.75 d_b$ on either side of the of the intentionally unbonded length when the beam moment is equal to the probable moment.[‡]
4. Neglect the contribution of the compression steel.

7.3.2 Given

The following variables are assumed to be given.

A_{ps}	f'_c	$L_{u, ps}$
A_s	f_y	$\epsilon_{ps, ini}$
b	f_u	ϵ_u
d	h	
d_b	L_u	

[‡]Tests at NIST have shown that mild steel bars grouted in ducts and subjected to cyclic loading will debond beyond the intentionally unbonded length. This distance varies and can be approximated by assuming the additional debond length will be equal to $2.75 d_b$ on either side of the intentionally unbonded length. See Appendix E.

Note that $L_{u, ps}$ is equal to $L_{clear}/2 + h_c/2$ if the PT steel is totally unbonded.

7.3.3 Procedure

Step 1:

- A. Compute the maximum force capacity of the mild steel, T_s .

$$T_s = A_s f_u \dots \dots \dots (10)$$

In accordance with the intent of Section 2, No. 8, the minimum area of bonded steel at the bottom of the connection shall satisfy:

$$A_s f_y \geq V_D + V_L$$

$$A_s \geq \frac{V_D + V_L}{f_y} \dots \dots \dots (11)$$

- B. Determine the value of ϵ_u corresponding to f_u from a σ - ϵ curve for the mild steel (eg. Figure C1 for Grade 60 bars in this example).
- C. Compute the elongation of the mild steel, Δ_s . The strain is assumed to be equal over the unbonded length.

$$\Delta_s = \epsilon_u (L_u + 5.5 d_b) \dots \dots \dots (12)$$

Step 2:

- A. Assume a neutral axis depth, c . The pivot for the joint rotation is assumed to occur at the neutral axis (see Figure 5).
- B. Compute the elongation of the PT steel, Δ_{ps} , due to flexure.

$$\Delta_{ps} = \left[\frac{\frac{h}{2} - c}{d - c} \right] \Delta_s \dots \dots \dots (13)$$

C. Compute the strain in the PT steel, ϵ_{ps} .

$$\epsilon_{ps} = \frac{\Delta_{ps}}{L_{ups}} + \epsilon_{ps, ini} \dots \dots \dots (14)$$

D. Obtain the stress in the PT steel, f_{ps} , from the σ - ϵ curve for Grade 270 prestressing strands (Appendix C). Check that $f_{ps} < 0.9 f_{pu}$.

$$f_{ps} \leq 0.9 f_u \dots \dots \dots (15)$$

If $f_{ps} > 0.9 f_{pu}$, then:

1. Increase the unbonded length of the PT steel or
2. Increase the amount of PT steel, or
3. Decrease the amount of mild steel.

Return to Step 1 if A_s is changed or to Step 2C if $L_{u, ps}$ is changed.

E. Compute the force in the PT steel, T_{ps} .

$$T_{ps} = A_{ps} f_{ps} \dots \dots \dots (16)$$

Step 3:

A. Compute the concrete compression force, C_c .

$$C_c = T_s + T_{ps} \dots \dots \dots (17)$$

B. Compute the neutral axis depth, c .

$$c = \frac{C_c}{0.85 f'_c b \beta_1} \dots \dots \dots (18)$$

C. Compare the computed value of c from Step 3B with the assumed value of c from Step 2A.

- D. If the computed value of c does not agree with the assumed value of c , set c to the value from Step 3B and repeat steps 2 and 3 until the value of c has converged.

Step 4:

- A. Compute the probable moment, M_{pr} , by summing moments about the concrete compressive force.

$$M_{pr} = M_s + M_{ps} \dots \dots \dots (19)$$

$$M_s = T_s \left(d - \frac{\beta_1 c}{2} \right) \dots \dots \dots (20)$$

$$M_{ps} = T_{ps} \left(\frac{h}{2} - \frac{\beta_1 c}{2} \right) \dots \dots \dots (21)$$

Step 5:

- A. Check M_s/M_{pr} ratio.

$$\frac{M_s}{M_{pr}} \leq 0.5 \dots \dots \dots (22)$$

If M_s/M_{pr} is greater than 0.5, reduce A_s and return to Step 1 or increase A_{ps} and return to Step 2E.

Sample calculations using the procedure outlined above for calculating M_{pr} are provided in Appendix D.

7.4 Maximum Drift Capacity

The maximum drift capacity is calculated by setting the mild steel strain equal to the steel strain (Figure C1, Point A) corresponding to the ultimate tensile strength. This calculated maximum drift capacity is a lower bound.

7.4.1 *Computation of Maximum Drift Capacity*

The procedure given in Section 7.3, Steps 1 to 3, is used to compute the location of the neutral axis and the following additional procedure is used to obtain the maximum drift capacity.

- A. The story drift capacity equals the beam rotation, θ , at the probable moment capacity. Since this procedure yields a lower bound for the story drift capacity, no capacity reduction factor is used.

$$\text{Story drift} = \theta \cdot \dots \dots \dots (23)$$

- B. Compute beam rotation, θ (Figure 5).

Using the value of c obtained in the calculation of the probable moment capacity, determine the beam rotation which is taken as the drift capacity.

$$\theta = \frac{\Delta_s}{d - c} \dots \dots \dots (24)$$

- C. Check that the drift capacity is greater than the drift demand as specified in Section 4.3. If the drift capacity does not meet the drift demand, then increase L_u .

8.0 NOMINAL MOMENT CAPACITY

8.1 GENERAL

The nominal moment capacity as calculated using Section 8.1 Method 1 or Method 2 replaces the nominal moment capacity in UBC Section 1910.2.

8.2 Calculation Procedure

Method 1

The nominal moment capacity is calculated following the procedure outlined in Section 7.3 with the following changes:

- The mild steel stress equal to f_y . Equation 10 changes to read
 $T_s = A_s f_y$.
- The mild steel strain is set equal to the strain at the onset of strain hardening, ϵ_{sh} . $\epsilon_{sh} = 0.01$ typically for Grade 60 bars.
- The total unbonded length is set equal to the intentionally unbonded length, L_u , of the mild steel. Equation 12 changes to read
 $\Delta_s = \epsilon_{sh} L_u$.

Method 2

$$M_n = 0.70 M_{pr} \dots \dots \dots (25)$$

where M_{pr} is calculated following the procedure outlined in Section 7.3.

The nominal moment capacity as obtained using Method 2 (Eq. 25) is recommended for its simplicity.

9.0 BEAM AND COLUMN DESIGN

9.2 Beam Design

The body of the beam away from the connection region shall be designed in accordance with UBC 1994 or ACI 318-95. Design the shear strength of the beam so that under the unfactored applied loads, such as gravity and the end moments associated with yielding of the connection, the design shear strength is greater than the applied moments. The design shear strength shall be:

$$\phi V_n = \phi (V_c + V_s) \geq V_u \dots \dots \dots (26)$$

where

$$V_u = \frac{M_{pr1} + M_{pr2}}{L_{clear}} + V_{D+L} \dots \dots \dots (27)$$

The value of V_c in Eq. 26 is not equal to zero as the prestress force in the beam from the PT would generally exceed $A_b f'_c/20$ [UBC 1921.4.5.2 (ACI 21.4.5.2)] and may be calculated per UBC 1911.3 (ACI 11.3).

In addition, the beam shall be designed so that at its design flexural strength, ϕM_n , it can carry a load of $(w_D + w_L)$ as a simply supported beam.

9.3 Column Design

Column design for the precast moment frame using the hybrid connections must satisfy capacity design requirements [UBC 1994 and ACI 318-95].

10.0 DETAILING REQUIREMENTS

10.1 Slab Interaction

It is important that the slab be prevented from contributing to the connection strength and to prevent concentrated rotation to occur at the beam ends. One possible method for achieving this is to provide a flexible filler material between the slab and the column at the beam-column joint. A 13 mm (0.5 in.) to 19 mm (0.75 in.) thick filler all around the column should be sufficient in most cases. Further measures may need to be taken to permit slab rotation adjacent to the beam-column joint and if significant slab damage is to be prevented during a maximum credible earthquake.

10.2 Unbonded Post-tensioning

Measures should be taken to prevent corrosion of the post-tensioning steel. Over the ungrouted length, corrosion inhibiting products are needed, while the bonded length can be protected by chloride free cementitious grout.

10.3 Unbonded Mild Steel Reinforcing

The length where the mild steel is intentionally unbonded from the grout is a crucial component in ensuring good connection behavior. If the unbonded length is too short, the mild steel may fracture before achieving the required drift demand. If the unbonded length is too long, the mild steel may not yield and the ability of the connection to dissipate energy will be significantly reduced. In addition, the amount of bar bonded to the beam must be sufficient to develop the ultimate strength of the bar. Measures should be taken to prevent corrosion of the mild steel.

10.4 Concrete Confinement

The concentrated rotation which occurs at the connection induces large concrete strains in the extreme fibers of the beam. In order to retain the section strength and minimize damage to the unconfined cover concrete, the concrete must be confined. The use of steel angles in the corners for the beam at the beam-column interface is recommended. The angle should extend at least the depth of the compression block, c , at the connection and 0.15 times the beam depth back into the beam. This angle must be provided with sufficient thickness and anchorage to prevent yielding or rotation at the connection's plastic limit state.

10.5 Beam End Shear and Confining Steel

Potential crack/shear planes, usually where the cross section changes, should be identified. Shear reinforcement in the form of closed ties should be used across these crack planes. Closed ties increase the confinement of the concrete in a region which experiences large compressive strains. These ties should be designed in accordance with the shear friction theory as per UBC Section 1911.7 (ACI 11.7).

ACKNOWLEDGEMENTS

Partial funding for the experimental work was provided by the Concrete Research and Education Foundation, American Concrete Institute. The authors would also like to thank Mr. Dean Stephan and Mr. Dave Seagren of Charles Pankow Builders, Inc. and Dr. John Stanton of the University of Washington for their technical guidance and support. Also, the very thorough and timely review of this report by Dr. Nicholas Carino of NIST is much appreciated.

REFERENCES

- ACI 318, (1995)**, "Building Code Requirements for Structural Concrete (ACI 318-95) and Commentary (ACI 318R-95)," American Concrete Institute, Detroit, MI, October.
- ASTM (1988)**, Annual Book of ASTM Standards, Vol. 1.04, American Society for Testing and Materials, Philadelphia, PA.
- BOCA [1993]**, "National Building Code," Building Officials and Code Administrators International Inc., Country Club Hills, IL.
- Cheok, G. S. and Lew, H. S. [1990]**, "Performance of 1/3-Scale Model Precast Concrete Beam-Column Connections Subjected to Cyclic Inelastic Loads," NISTIR 4433, NIST, Gaithersburg, MD, October.
- Hawkins, N. M, and Ishizuka, T. (1988)**, "Concrete Ductile Moment Resistant Frames," Proceedings of the Ninth World Conference on Earthquake Engineering, Tokyo, Japan.
- International Conference of Building Officials (1994)**, "Uniform Building Code: Volume. 2, Structural Engineering Design Provisions," Whittier, CA, May.
- Mattock, A. (1979)**, "Flexural Strength of Prestressed Concrete Sections by Programmable Calculator," PCI Journal, Vol. 24, No. 1, Precast-Prestressed Concrete Institute, Jan/Feb, pp. 32-55.
- Mole, A. (1994)**, "Seismic Response of Hybrid Connections in Precast Concrete Frames," Thesis for degree in Master of Science in Engineering, University of Washington, Seattle, WA, December.
- NEHRP [1991]**, "Recommended Provisions for the Development of Seismic Regulations for New Buildings," Part 1, Federal Emergency Management Agency, Washington, D. C.
- Stone, W. C., Cheok, G. S., Stanton, J. F. (1995)**, "Performance of Hybrid Moment-Resisting Precast Beam-Column Concrete Connections Subjected to Cyclic Loading," ACI Structural Journal, Vol. 92, No. 2, American Concrete Institute, Detroit, MI, March-April.
- Stone, W. C., Cheok, G. S., Kunnath, S. K.**, "Seismic Response of Precast Concrete Frames with Hybrid Connections," in progress.
- SBC [1994]**, "Standard Building Code," Southern Building Code Congress International Inc., Birmingham, AL.
- Winter, G. and Nilson, A. H. (1972)**, "Design of Concrete Structures," McGraw-Hill Book Company, New York.

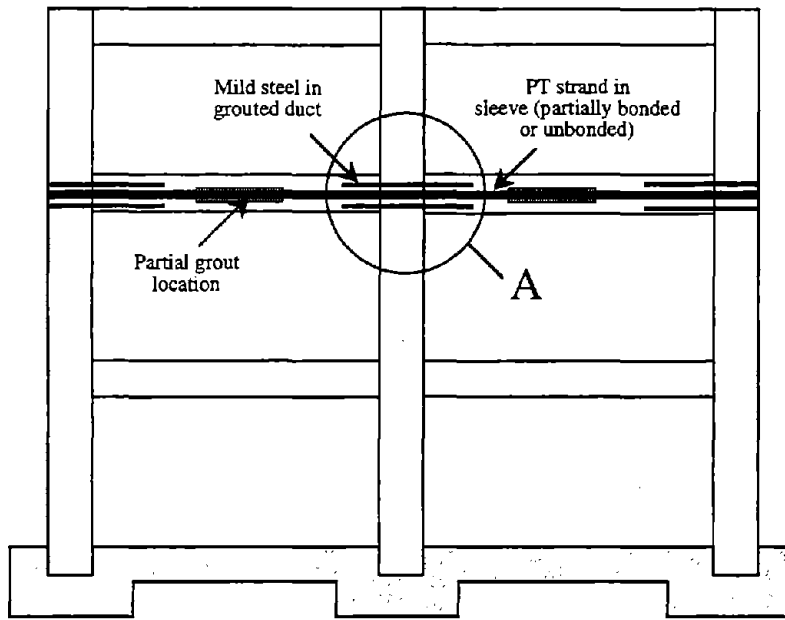

Elevation

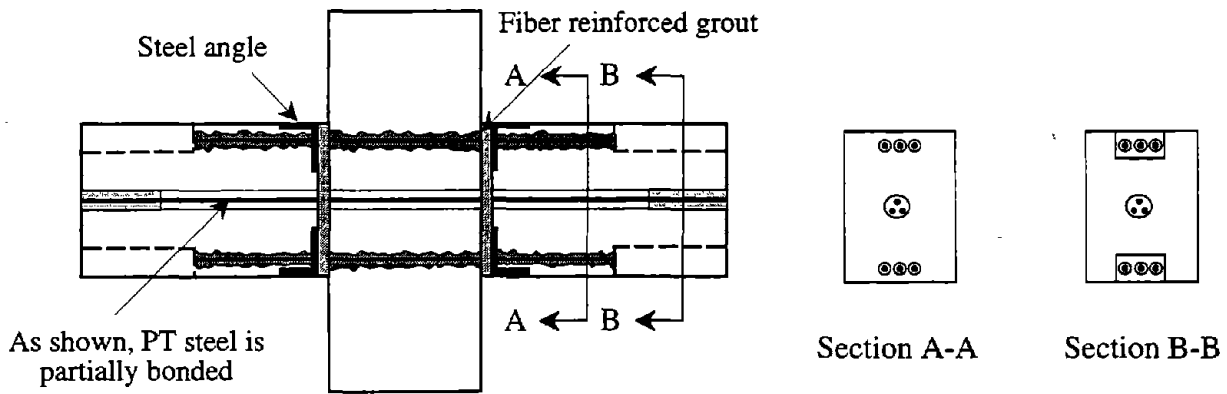

Note: Column bars omitted for clarity

Detail A

Figure 1. Precast Hybrid Moment Connection.

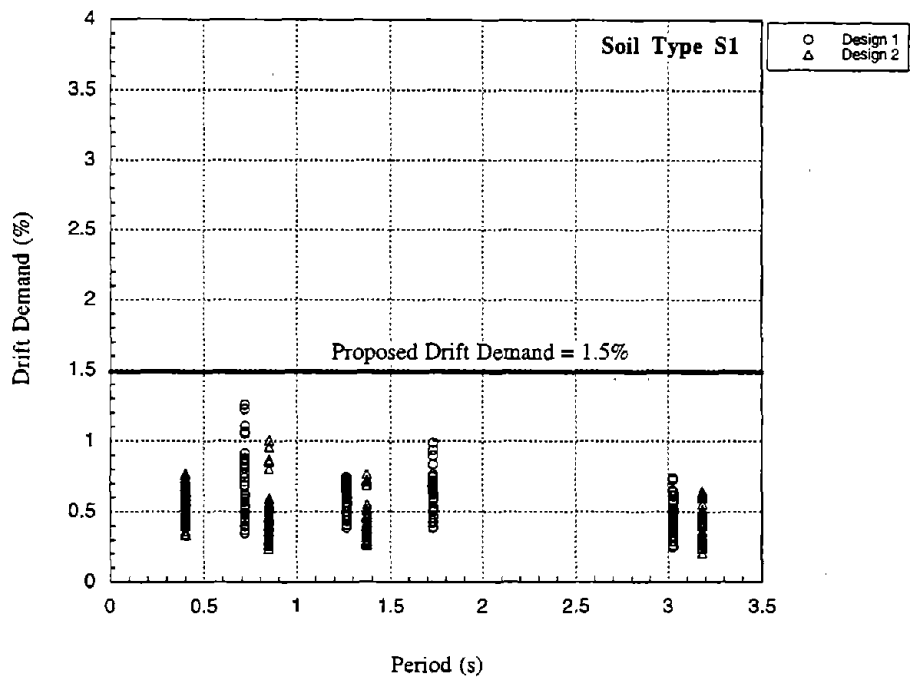

Figure 2. Drift Demand for UBC Soil Type 1.

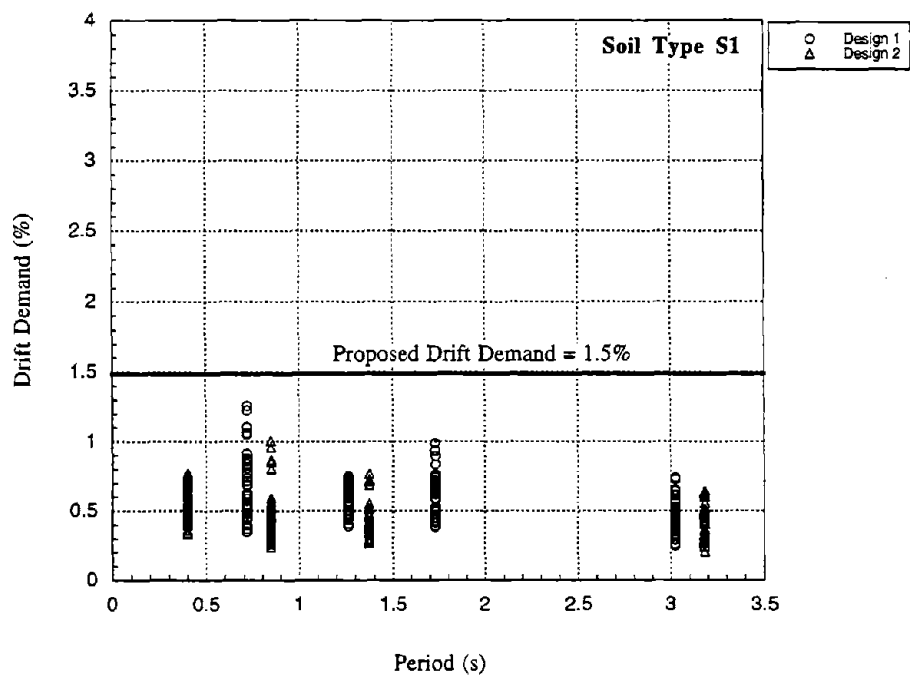

Figure 3. Drift Demand for UBC Soil Type 2.

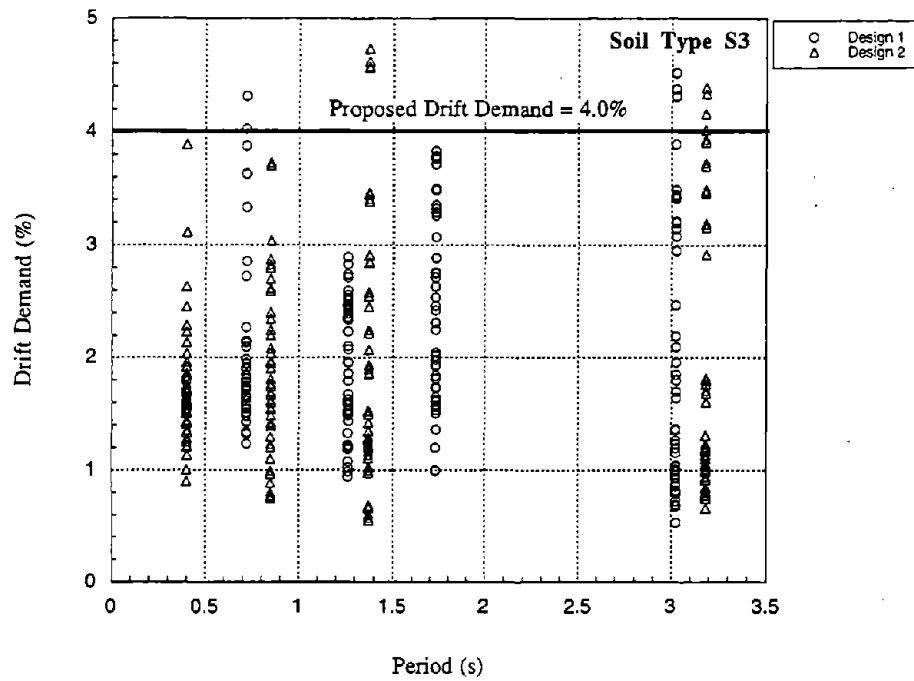

Figure 4. Drift Demand for UBC Soil Type 3.

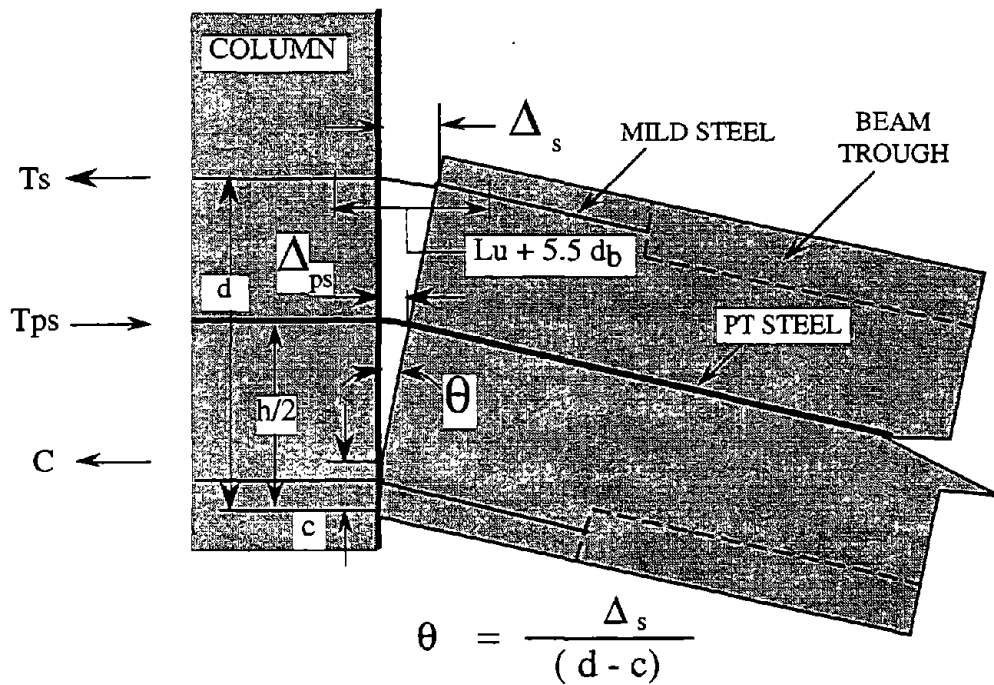

Figure 5. Rotation at the Beam-Column Joint.

SUMMARIES OF APPENDICES

1. *Appendix A: Commentary*

This appendix contains the commentary of the design procedure.

2. *Appendix B: ICBO Acceptance Criteria*

The proposed acceptance criteria for the hybrid connection is based on the acceptance criteria for another connection system for a special moment resisting frame that has been approved by ICBO.

3. *Appendix C: Representative Stress-Strain Curves for Steel*

Representative curves for ASTM 615 Grade 60 reinforcing bars used as energy dissipators and Grade 270 prestressing strands are given. In addition, an equation for relating the stress to the strain for the Grade 270 strands is also given.

In practice, the designer may use a representative or an actual stress-strain curve for the energy dissipating bars. The actual stress-strain curves are obtained from tension tests of the material through fracture. If reinforcing bars are used, bars meeting ASTM 706 specifications are recommended.

4. *Appendix D: Sample Calculations for NIST Specimens*

Sample calculations of the probable moment (M_{pr}), drift capacity (θ), and the nominal moment (M_n) using the proposed design procedure are given. These calculations, and all others in the Appendices, were made using the PC software Mathcad. These calculations are presented in SI units and in inch-pound units, with the former being presented first.

5. *Appendix E: Calculations to Estimate the Additional Debonded Length of the Mild Steel Bars.*

Based on measurements during the NIST tests and an assumed strain in the mild steel bars of 0.088, a debonded length was calculated for each specimen. These measurements were of the gaps, at top and bottom of the beam, that opened between the beam and the column during the tests.

6. *Appendix F: Determination of M_s/M_{pr} Ratio.*

The calculations in this appendix are made by setting the area of mild steel to the maximum area [Mole, 1994] and computing the M_s/M_{pr} ratio. These calculations are presented in SI units and in inch-pound units with the former being presented first.

There has to be sufficient force in the PT steel to overcome the yielding of the mild steel in compression to close the gap between the beam and column during load reversal. To ensure this, a limit on the amount of mild steel is imposed as suggested by Mole (1994). The calculations in this appendix show that this imposed limit results in M_s/M_{pr} ratios of 0.5 for the test specimens. This is the basis for the recommendation in Step 5 of the procedure in Section 7.3.3.

APPENDIX A: COMMENTARY

C1.0 INTRODUCTION

The proposed design procedure is based on physical tests of three 1/3-scale models of the hybrid connections. The test program is described in Stone, Cheok and Stanton [1995]. A comparison of this design procedure with the experimental results is contained in Appendix D.

C3.0 CONSTRUCTION SEQUENCE

5. The grout used should have good workability to ensure that joint at the beam-column interface is completely grouted to maximize friction resistance. To maintain the prestress in the PT steel, the loss of the grout at the beam-column interface due to crushing under high compressive forces must be minimized. Therefore, toughness of the grout is an important property. The use of a fiber reinforced grout is recommended as this type of grout worked well in the NIST tests [Stone et. al., (1995)]. The fibers used were commercially available 13 mm (1/2 in.) fibers and the dosage used was 1.78 kg/m³ (3 lb/yd³). A non-shrink grout was used.
7. The mild steel bars are unbonded for a short length on either side of the beam-column interface to delay fracture of these bars. However, for the mild steel bars to function as intended, energy dissipators, it is important that adequate development lengths [UBC Section 1921.5.4 (ACI 21.5.4)] are provided.

The PT steel in the NIST test specimens were partially bonded [Stone, et. al., (1995)]. A totally unbonded PT steel system dissipates less energy than hybrid or monolithic system. This will likely result in reduced damping of the unbonded system. However, a series of inelastic dynamic analyses show that the drift demand of a system is more dependent on the soil type and the characteristics of the input motion rather than the energy dissipation capacity of the system (see Section C4.3).

C4.0 DESIGN FORCES

The precast moment frame using hybrid connections was developed to achieve the design objectives contained in the UBC [UBC, 1994]. Three levels of seismic performance are considered [SEAOC, 1990]:

1. Resist a *minor* level of earthquake ground motion without damage;
2. Resist a *moderate* level of earthquake ground motion without structural damage, but possibly experience some nonstructural damage.

3. Resist a *major* level of earthquake ground motion, having an intensity equal to the strongest either experienced or forecast for the building site, without collapse, but possibly with some structural as well as nonstructural damage.

C4.1.2 Load Combinations

Design seismic forces, as defined in the UBC, are developed using an R_w factor equal to 12. The resulting factored design forces represent the effect of a moderate earthquake. Therefore, structural damage is not allowed at this limit state. This is achieved by requiring the design (ϕM_n) strength to be greater than the required moment.

C4.3 Maximum Drift Demand

Preliminary results from current extensive non-linear time history analyses at NIST [details of the analyses may be found in Stone et. al. (in progress)] have shown that the drift demand during an earthquake is more dependent on the soil type and the period of the structure and to a lesser extent on the energy dissipation capacity of the system as measured by the parameter M_s/M_{pr} . Therefore, it is unreasonable to impose a single value for the drift requirement.

The time history analyses were based on multi degree of freedom (MDOF) models with varying periods subjected to 29 earthquake records in which the amplitudes of the record were scaled to the UBC response spectra for soil types 1 to 3. The scale factors were chosen so that the error between each scaled spectrum and the corresponding UBC spectrum was minimized for periods ranging from 0.4 s to 2.2 s. The acceleration records are listed in Table A1.

The MDOF models are 2-D, 4 bay frames with varying building heights - 4, 8, 12, and 22 stories. Material, geometry, and hysteretic properties were calibrated to the NIST experimental tests of both monolithic and hybrid connections. Design moments for soil types 1, 2, and 3 were calculated and incorporated into the MDOF models. The main difference in the MDOF models was the energy dissipation capacity of the connection. The models represented connections that dissipated very little energy to connections that represented cast-in-place systems. The coefficients for the seven parameter hysteretic failure model for each MDOF model were calibrated against the experimental data.

Drift demands obtained from non-linear time history analyses are shown in Figures A1-A4. In these figures, the values on the abscissa, which represent the ratio of the moment contributed by the mild steel to the probable moment capacity (M_s/M_{pr}), range from 0 to 1.0. A value of zero represents a connection which contains only PT steel with no mild steel and which dissipates the least amount of energy. A value of 1 represents a cast-in-place connection which contains only mild steel with no PT steel and which dissipates the most energy.

Figures 2-4 are a different representation of the data in Figures A1-A4. The two symbols represent two sets of runs for two different designs of beams and columns.

C5.0 VERTICAL SHEAR RESISTANCE

C5.1 General

Both of the mechanisms providing the vertical shear resistance have been shown [Stone et. al., 1995] to be reliable in resisting the imposed shear forces, eliminating the need for corbels. To assure that the two mechanisms are reliable, certain requirements must be met: 1) ensure that the PT force is never lost and 2) ensure that the compression portion of the moment couple is sufficient to resist the corresponding induced shears.

C5.2 Minimum Clamping Force

Due to the cyclic nature of earthquake moments, there will be a time during every cycle when the full dead and live shear loads will be imposed on the interface, and the corresponding seismic moment is zero. Therefore, it is prudent to provide a clamping force, F_p , to resist the entire gravity shear loads and rely on the moment induced compression force to resist seismic shear forces (Section 5.3).

C5.3 Span-to-Depth Ratio

It can be shown that the shear at the beam-column interface induced by the seismic deformations can be resisted by the moment-induced compression force, C , if the beam has a large enough L/h ratio. By equating the seismically induced shear force to the frictional resistance provided by the compression force of the moment couple, the following is obtained:

$$\phi \mu C \geq \frac{M_{pr1} + M_{pr2}}{L_{clear}} \dots \dots \dots (A1)$$

Assuming that the PT steel is located at the mid-height of the beam, the beam rotates about the neutral axis and there is no mild compression steel, the compression portion, C , of the moment couple is

$$C = \frac{M}{\left(\frac{h}{2} - \frac{\beta_1 c}{2}\right)}$$
$$C = \frac{2M}{h - \beta_1 c} \dots \dots \dots (A2)$$

The compressive force, C , decreases as the neutral axis depth, c , decreases. In the limit, the lowest value of C corresponds to $c = 0$. With equal probable moment capacity at each end of

the beam, $M_{pr1} = M_{pr2} = M$, the minimum clear span to overall member thickness ratio to prevent slip is

$$\frac{L_{clear}}{h} \geq \frac{1}{\phi \mu} \dots\dots\dots (A3)$$

From Eq. 9, using a conservative value of $\mu = 0.6$, $\phi = 0.85$ and $\gamma = 0.8$, the code required clear span to effective depth, L/d , ratio of 4 [UBC 1921.3.1.2 (ACI 21.3.1.2)] is more than sufficient to ensure adequate vertical shear resistance.

If the contribution of the mild compression steel were not neglected, the compression force is reduced by the compression yielding of the mild steel. Equation A2 would be

$$C = \frac{2M}{h - \beta_1 c} - C'_s \dots\dots\dots (A4)$$

where $C'_s = A'_s f_y$. For $C'_s = C$ and $c = 0$,

$$C = \frac{M}{h} \dots\dots\dots (A5)$$

and Eq. 9 would become

$$\frac{L_{clear}}{d} = \frac{2}{\phi \mu \gamma} \dots\dots\dots (A6)$$

For $\mu = 0.6$, $\phi = 0.85$, and $\gamma = 0.8$, the required L/d ratio is 4.9 which is greater than the code required minimum L/d ratio of 4. However, the values for $\mu = 0.6$, $C'_s = C$, and $c = 0$ (Eq. A5) are conservative. If μ were equal to 1.0 as recommended in Section 5.1, the code required minimum L/d ratio would be sufficient to ensure adequate vertical resistance.

C5.4 Corbels

It is important that free rotation (see Figure A5) of the beam at the beam-to-column interface is allowed as any inelastic action in the beam is designed to occur there. If corbels are used, they could also provide redundant vertical shear resistance.

C6.0 MINIMUM AND MAXIMUM PRESTRESS

C6.1 Strand Stresses

Experimental work [Stone et. al., 1995] has shown that for an L/h ratio of 4.5 a maximum prestress of $0.45 f_{pu}$ is sufficient to ensure that the PT steel does not yield when subject to a story drift of 4%. Prestress limits for other L/h ratios will have to be determined using the criterion that the PT does not yield.

C6.2 Concrete Stresses

Early studies [Cheok and Lew, 1990] have shown that the average concrete prestress in the beams could be as high as $0.15 f'_c$ [6.9 MPa (1000 psi)] without having an adverse effect on the connection performance. In the tests [Stone, et. al., (1995)], the average beam prestress level in the hybrid connection exceeded the current code limit of 2.4 MPa (350 psi) [NEHRP (1991), BOCA (1993), Standard Building Code (1994)]. This code limit was based on tests [Hawkins and Ishizuka, 1988] of beams without additional confinement and would not apply to the hybrid connection as additional confinement of the concrete is provided by steel angles located at the corners of the beams [Stone et.al. (1995)]. Thus, the maximum limit on the concrete prestress would be controlled by concrete strength and provided confinement of the compression zones. Determination of this maximum limit requires further research.

C7.0 PROBABLE MOMENT CAPACITY

C7.3.3 Procedure

Step 1:

- A. This provision is intended to prevent progressive collapse if the PT should fail. The value is obtained by assuming that any top reinforcing bars have pulled out of the beam and do not contribute to the shear resistance and that the bottom bars are hanging at 45° and are stressed to $1.5 f_y$. The bars will also provide shear resistance once the temporary supports have been removed.
- B. A σ - ϵ curve for the actual material used in construction would be ideal. However, if this is not available, representative σ - ϵ curves for the specified steel used may be used. The level of confidence in the values of ϵ_u and f_u should be very high.

Different stress-strain curves may be used for other types of mild steel. However, if reinforcing bars are to be used as energy dissipators, the bars should meet ASTM 706 [ASTM, 1988] specifications. This is based on the premise that ASTM 706 bars are likely to result in more consistent or uniform stress-strain curves than bars meeting ASTM 615 specifications. Thus, the use of a "representative" stress-strain curve for ASTM 706 bars would yield smaller errors than for ASTM 615 bars and will increase the confidence in the values for ϵ_u and f_u .

C. Compute the elongation of the mild steel, Δ_s .

$$\Delta_s = \epsilon_u (L_u + \alpha d_b) \dots\dots\dots (A7)$$

A value of 5.5 is proposed for α because an additional debonded length of 5.5 d_b was obtained from calculations based on measurements of the gap between the beam and the column during the experimental tests [Stone et. al. (1995)]. See Appendix E for these calculations.

The unbonded length after repeated cycles at large rotations has been shown to be the original unbonded length, L_u , plus 5.5 d_b . (See Appendix D). However, this value is based on only one bar size, and two test specimens. In addition, this value is valid for these two specimens at the end of the test (i.e. only valid for calculations of the probable moment). Additional tests to determine the effects of bar size, concrete strength, etc. on the additional debond length will have to be conducted.

While further research is required to validate the empirical equation (Eq. 12), it is conservative to use this equation for the following reasons:

1. A larger Δ_s creates a larger stress in the PT steel;
2. A larger PT stress causes a larger moment capacity;

Also, a larger unbonded length requires additional bar length to ensure the required development length of the mild steel is provided.

For capacity design, the value calculated for M_{pr} should be as large as could possibly be developed. Therefore, it is prudent to include the additional debonded length in the calculation of M_{pr} . For calculation of the nominal moment capacity, M_n , only the original unbonded length should be used.

Step 2:

D. This step is a check that the PT steel does not yield. The yield stress in the PT steel is set at 0.9 f_{pu} . Typical PT yield stress ranges from 0.90 f_{pu} to 0.95 f_{pu} .

Step 5:

To ensure that during load reversal the gap between the beam and the column is closed at zero drift, there has to be sufficient PT force to cause compression yielding of the mild steel. This condition can be achieved by placing a limit on the amount of mild steel or the M_y/M_{pr} ratio.

A limit of 0.5 is proposed based on equations developed by Mole [Mole, 1994] for the computation of the maximum area of mild steel and the results from the three NIST tests. Sample calculations to determine the maximum M_y/M_{pr} ratio are given in Appendix F.

C7.4 Maximum Drift Capacity

It should be noted that the drift capacity calculated as outlined in this section is different from the drift demand (Section 4.3). The ratio of the drift capacity to the drift demand is in a sense the safety factor.

The proposal that the maximum drift capacity be calculated by setting the mild steel strain equal to the steel strain (Figure C1, Point A) corresponding to the ultimate tensile strength is based on NIST tests [Stone, et. al., 1995]. In the NIST experimental tests, failure of the hybrid connections occurred when the mild steel bars fractured, which happened one to three cycles beyond the cycle corresponding to the probable moment. As shown in Figure C1, by comparing the strain at Point A and the strain at bar fracture, the resulting calculated maximum drift capacity would therefore underestimate the actual maximum drift capacity and can be taken as a lower bound.

C7.4.1 Computation of Maximum Drift Capacity

- A. Plots of the experimental ratio of the beam rotation to the total drift versus the total drift are shown in Figures A6-A9. Beam rotation was measured at the beam-column interface. The total drift was computed by dividing the displacement at the top of the column by the story height. As seen in Figures A6-A9, as the hybrid connections approached failure (3% - 3.5% drift), all rotation of the connection is essentially concentrated at the beam-column joint. Therefore, it is proposed that the story drift capacity equals the beam rotation at the probable moment capacity.

As stated previously, this procedure yields a lower bound for the story drift capacity. Therefore, no capacity reduction factor is used.

- B. Compute beam rotation, θ .

As seen in Eq. 12, the beam rotation is directly dependent on ϵ_u and α . Thus, the reliability of the calculated story drift depends on the accuracy of ϵ_u and α .

This procedure yields a moment that is equal to the probable moment, and thus, the check which requires the moment be greater than $0.8 M_{pr}$ is not needed.

C8.0 NOMINAL MOMENT CAPACITY

C8.2 Calculation Procedure

The nominal moment capacity of the beam is used in the required strength calculations of the frame. These calculations are used to design a system which satisfies the requirements of the limit state associated with a moderate earthquake. Under a moderate earthquake, structural damage is not permitted. The precast hybrid moment connection has been shown by experiment to sustain only minor damage even up to very high deformations. However, to be consistent with traditional cast-in-place frame design, the stress in the mild steel will be limited to f_y at nominal moment capacity. The reinforcing steel strain in a traditional system exceeds the yield strain. Therefore, the mild steel strain for this limit state is set equal to ϵ_{sh} .

Method 1

It is assumed that no debonding of the mild steel has occurred at this moment capacity level ($\alpha = 0$ in Eq. A7). Also, the strain is assumed to be equal over the intentionally unbonded length of the mild steel, L_u .

Method 2

The reason for proposing the 0.70 factor is described in Appendix F. Also, M_n as calculated using Method 1 depends on the accuracy of the value used for ϵ_{sh} of the mild steel. However, calculations with ϵ_{sh} varying by $\pm 50\%$ of 0.01 resulted in moments approximately equal to 98% and 104% of M_n where M_n was calculated using $\epsilon_{sh} = 0.01$.

Equation 25 results in an overstrength factor of 1.43 which meets the proposed acceptance criteria outlined in Appendix B.

C9.0 BEAM AND COLUMN DESIGN

C9.2 Beam Design

The use of unfactored applied loads is based on the rationale given in ACI R21.3.4.1.

The assumption of a simply supported beam is related to the condition stated in Section C7.3.3 (Step 1, A) whereby the PT is lost and the only means of support for the beam is the bottom steel in the beam. In such a situation, it was felt that the beam would be considered to be simply supported at both ends.

C10.0 DETAILING REQUIREMENTS

C10.1 Slab Interaction

This provision is included since all of the critical section properties are those at the connection. All of the experimental work, as well the analytical methods, neglect the effect of a slab on the connection performance.

While technically the amount of the filler should be related to the beam depth and rotation capacity, 13 mm (0.5 in.) to 19 mm (0.75 in.) of filler all around the column should be sufficient for most practical cases.

C10.4 Concrete Confinement

The addition of steel angles in the corners of the beams to confine the beam concrete in regions of large concrete strains has to shown to be successful. During the NIST tests [Stone et. al., 1995], corner angles were used for confinement purposes and to limit damage to the beam concrete (Figure 1). In these tests, the angle extended 0.19 h vertically and 0.12 h back into the beam where h is the overall depth of the beam.

Table A1. Earthquake Records.

Station Name	Earthquake Name ^a	Epicentral Distance (km)	UBC Soil Type	Scale Factor ^b
1. Caltech Seismic Lab	San Fernando	34	1	2.9
2. Castaic, Old Ridge Rte.	Whittier	69	1	4.8
3. Corralitos, 1473 Eureka Canyon Rd.	Loma Prieta	7	1	0.6
4. Gilroy #1, Gavilan College	Loma Prieta	29	1	1.8
5. Griffith Park Office	San Fernando	33	1	1.8
6. Pacoima, Kagel Canyon	Whittier	38	1	4.4
7. Pacoima Dam	San Fernando	8	1	0.5
8. Santa Cruz, UCSC/Lick Lab	Loma Prieta	16	1	1.6
9. Superstition Mountain	Imperial Valley	58	1	1.9
10. Garvey Reservoir	Whittier	3	1	1.6
11. 8244 Orion Blvd, LA	San Fernando	20	2	1.4
12. 900 S. Fremont, Alhambra	Whittier	7.3	2	4.0
13. Caltech Athenaeum	San Fernando	37	2	3.4
14. Caltech JPL	San Fernando	29	2	4.7
15. Caltech Milikan Library	San Fernando	37	2	2.9
16. Hollywood Storage Bldg., LA	Whittier	24	2	3.3
17. Hollywood Storage P.E. Lot, LA	San Fernando	36	2	3.5
18. Palmdale Fire Station	San Fernando	33	2	3.8
19. Pumping Plant, Pear Blossom	San Fernando	48	2	10.0
20. El Centro Array #3	Imperial Valley	26	3	1.2
21. El Centro Array #2	Imperial Valley	26	3	1.7
22. 288 Vernon, CMD Bldg.	San Fernando	49	3	4.8
23. 4814 Loma Vista, CMD Bldg.	Whittier	13	3	2.9
24. El Centro Array #1, Dogwood Rd.	Imperial Valley	26	3	1.7
25. Gilroy Array Station #2	Loma Prieta	23	3	1.9
26. El Centro Array #5, James Road	Imperial Valley	28	3	1.7
27. Outer Harbor Wharf, Oakland	Loma Prieta	98	3	1.5
28. San Francisco International Airport	Loma Prieta	24	3	1.7
29. Naval Base Fire Station, Treasure Island	Loma Prieta	111	3	3.5

^a Magnitudes: Imperial Valley (1979) = 7, Loma Prieta (1989) = 7, San Fernando (1971) = 6.6, Whittier (1987) = 6.1

^b The acceleration records were scaled by this factor in the dynamic analyses.

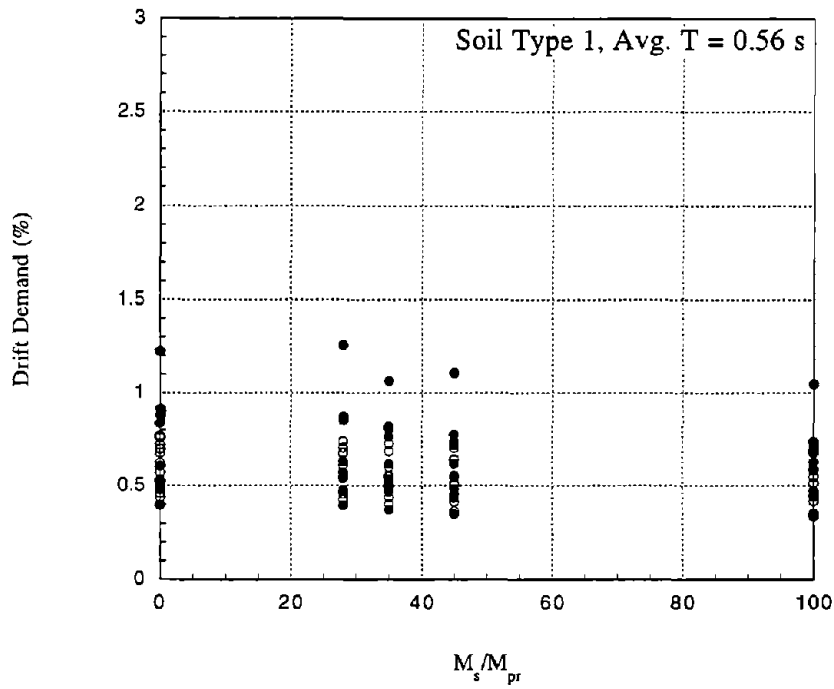

Figure A1a. Drift Demand for UBC Soil Type 1, T = 0.56 s.

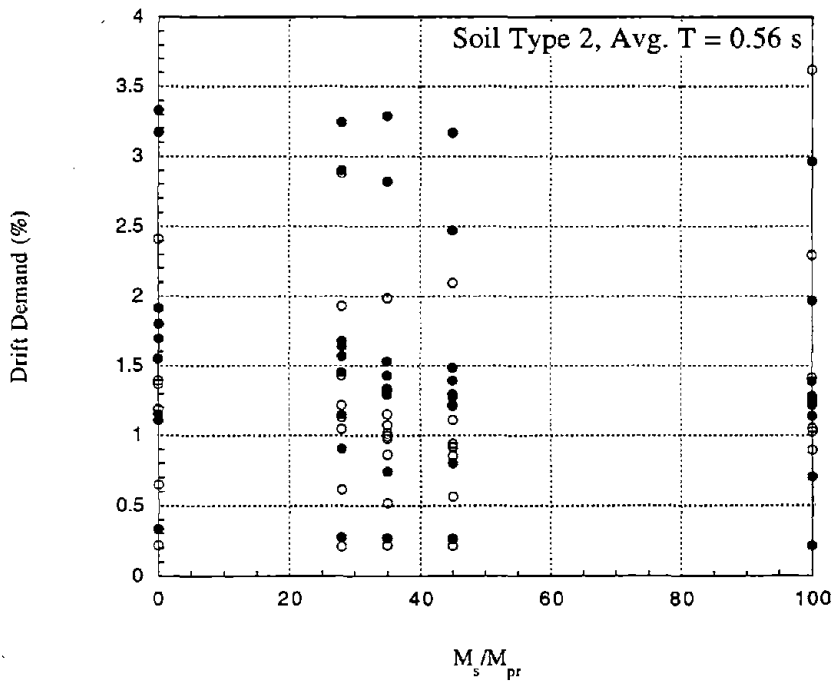

Figure A1b. Drift Demand for UBC Soil Type 2, T = 0.56 s.

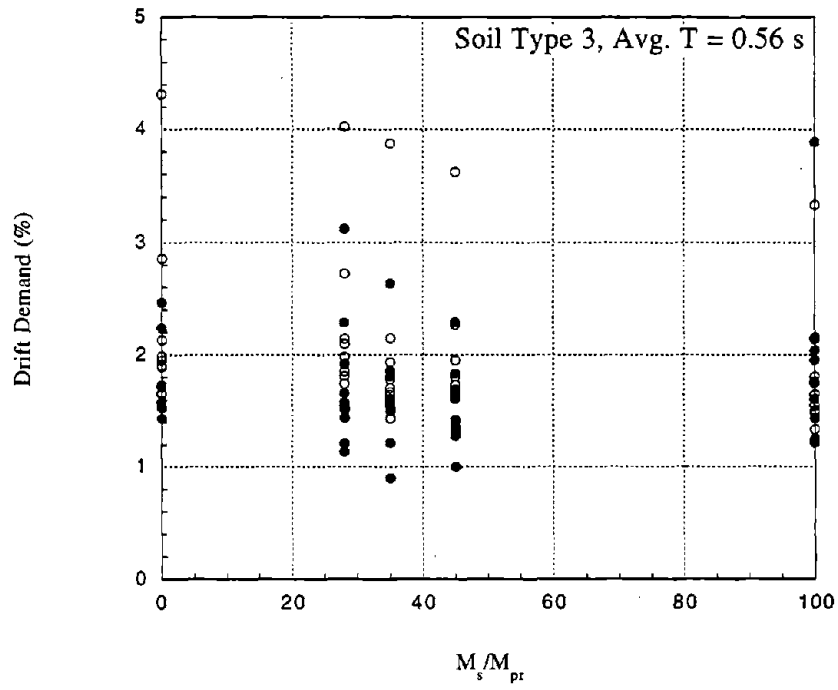

Figure A1c. Drift Demand for UBC Soil Type 3, T = 0.56 s.

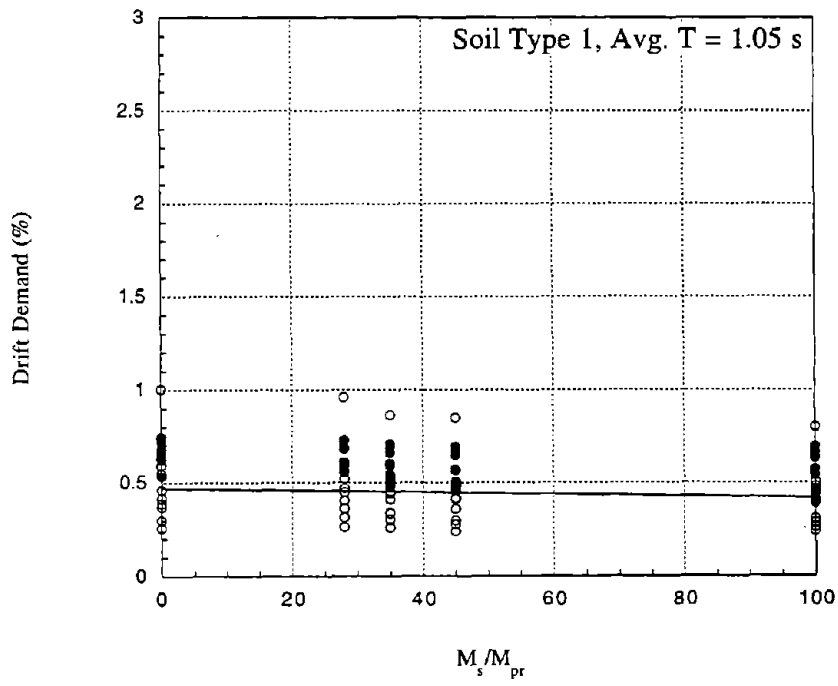

Figure A2a. Drift Demand for UBC Soil Type 1, T = 1.05 s.

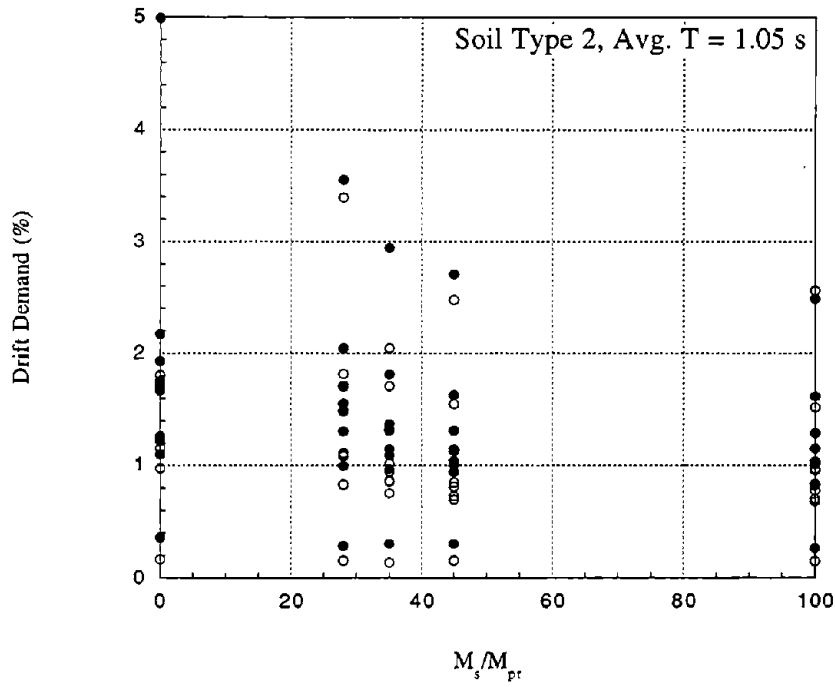

Figure A2b. Drift Demand for UBC Soil Type 2, $T = 1.05$ s.

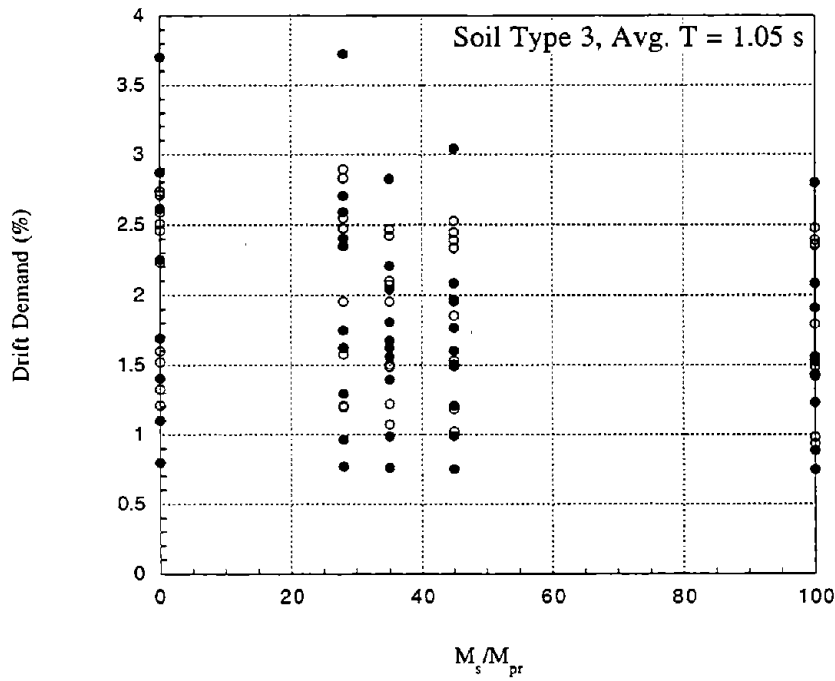

Figure A2c. Drift Demand for UBC Soil Type 3, $T = 1.05$ s.

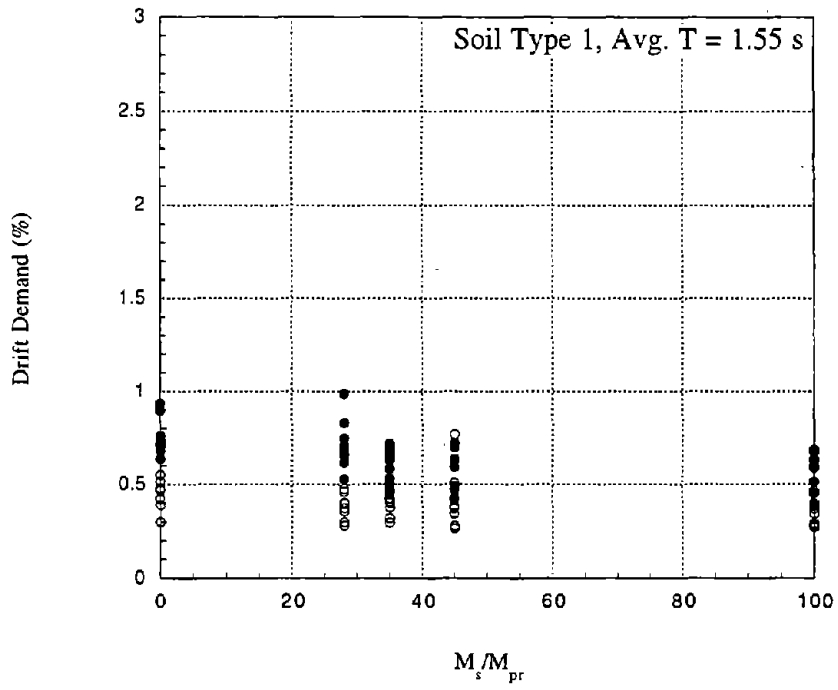

Figure A3a. Drift Demand for UBC Soil Type 1, T = 1.6 s.

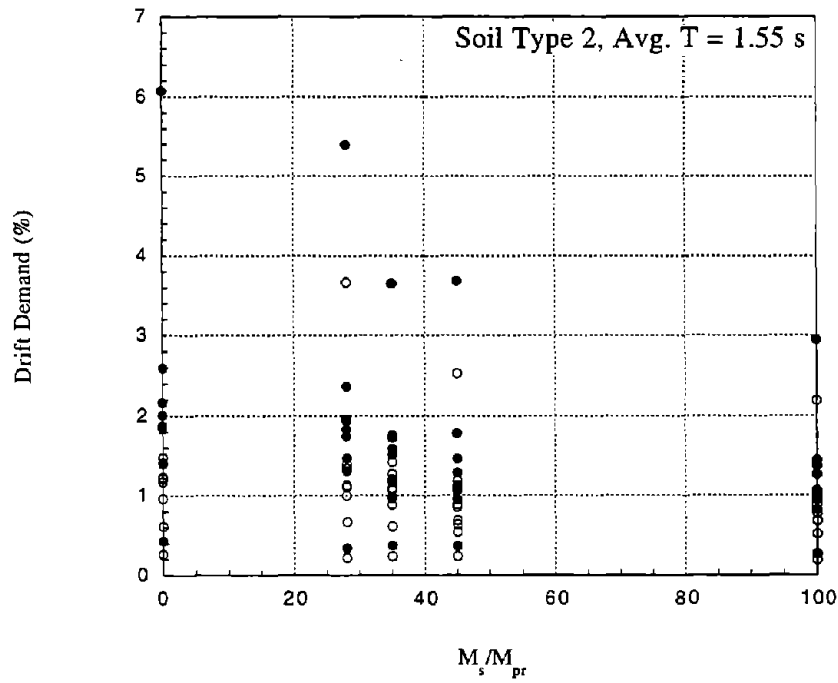

Figure A3b. Drift Demand for UBC Soil Type 2, T = 1.6 s.

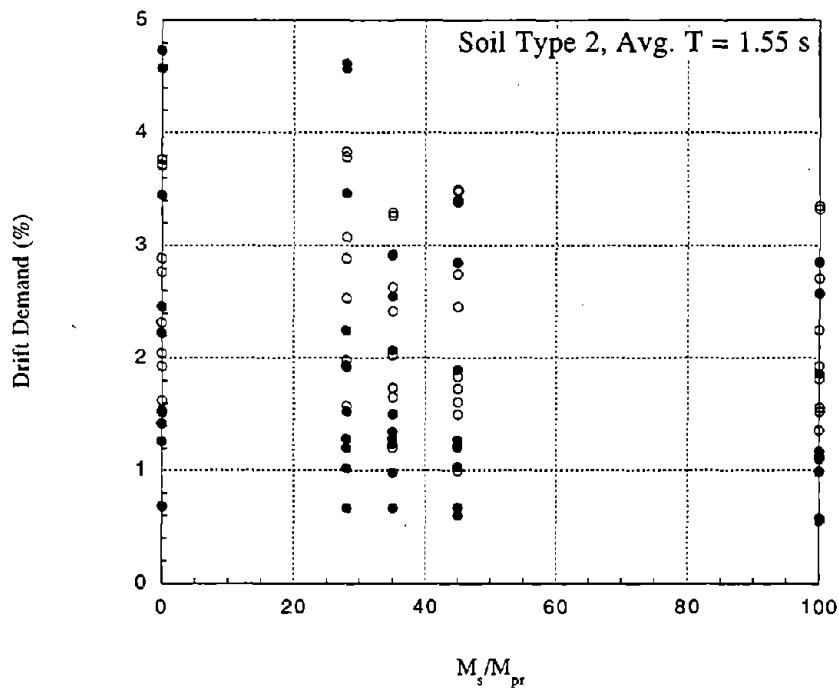

Figure A3c. Drift Demand for UBC Soil Type 3, T = 1.6 s.

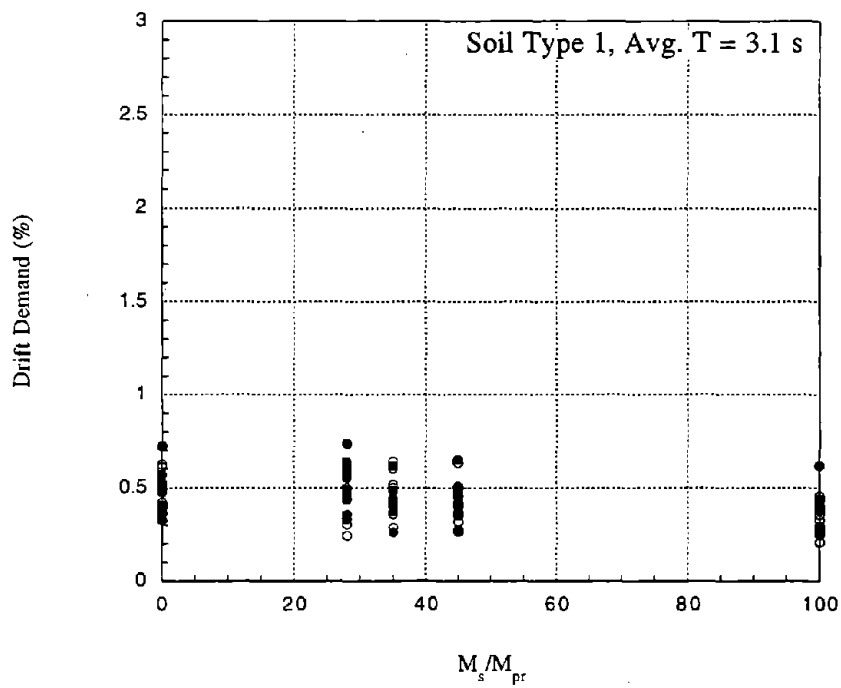

Figure A4a. Drift Demand for UBC Soil Type 1, T = 3.1 s.

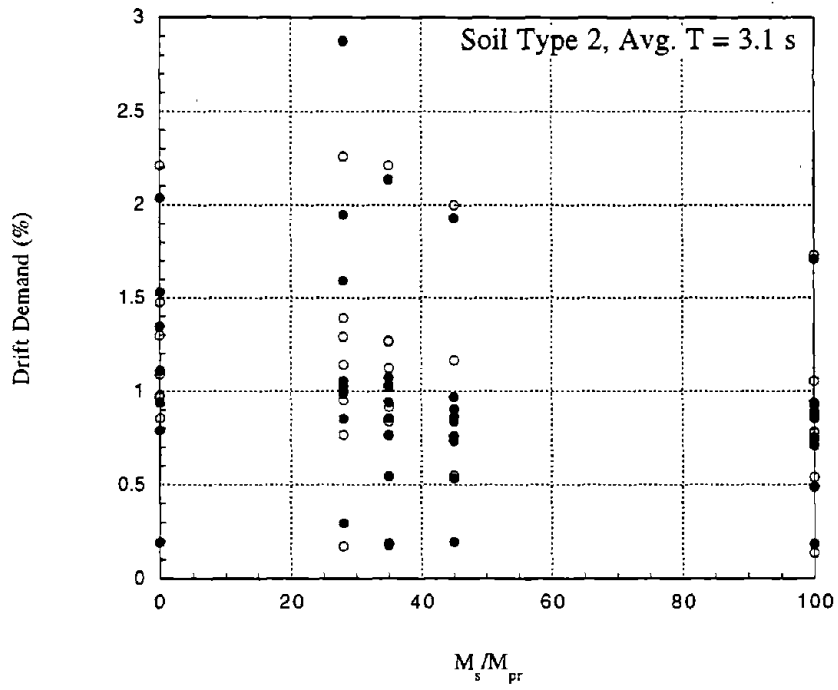

Figure A4b. Drift Demand for UBC Soil Type 2, T = 3.1 s.

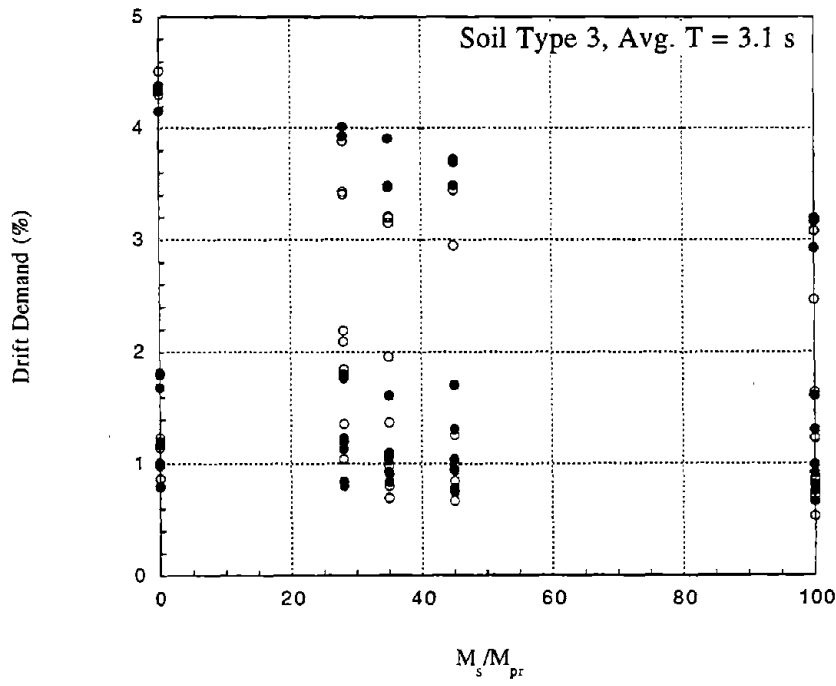

Figure A4c. Drift Demand for UBC Soil Type 3, T = 3.1 s.

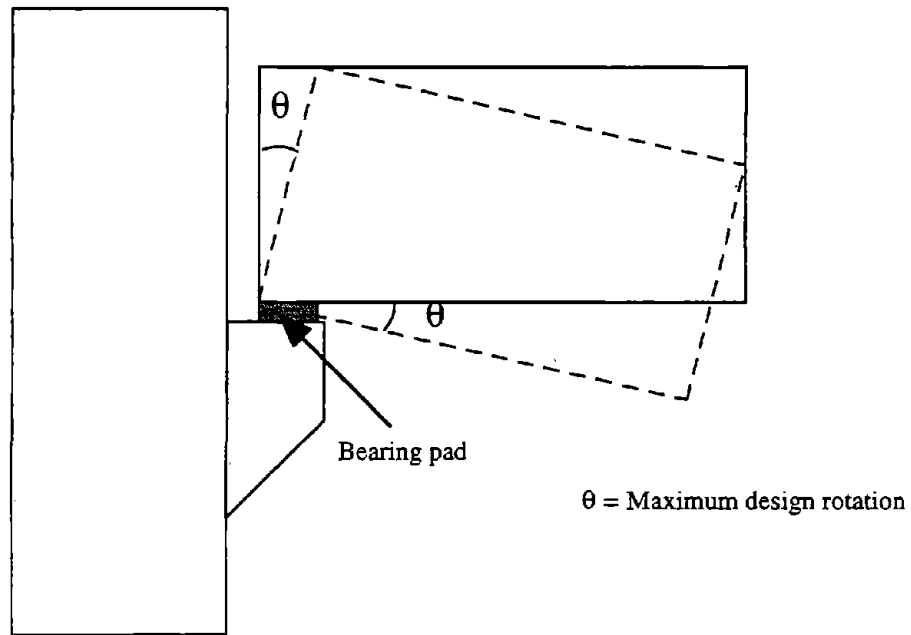

Figure A5. Free Rotation of Beam with Corbel Present.

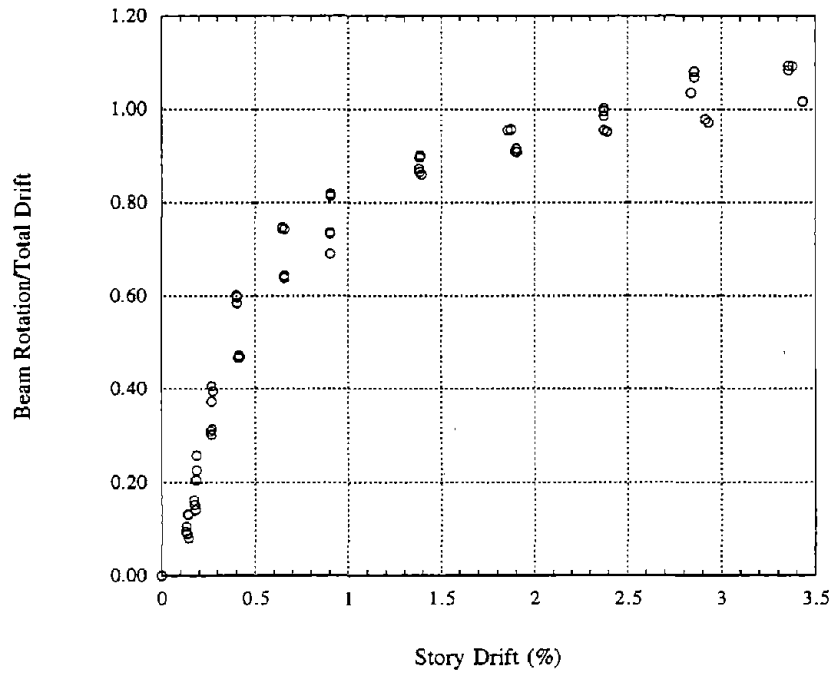

Figure A6. Comparison of Rotation (θ) at the Beam-Column Joint to Connection Rotation, M-P-Z4.

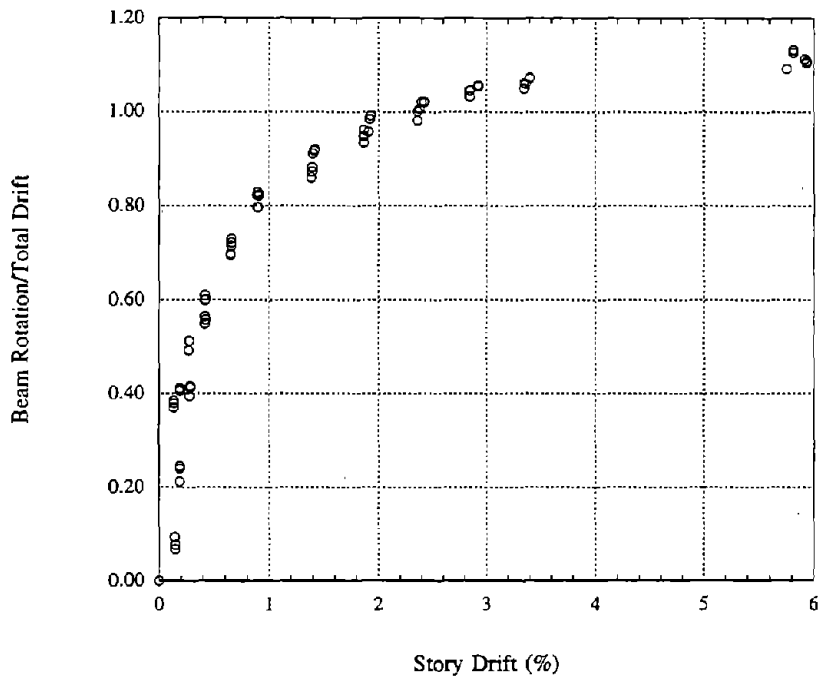

Figure A7. Comparison of Rotation (θ) at the Beam-Column Joint to Connection Rotation, N-P-Z4.

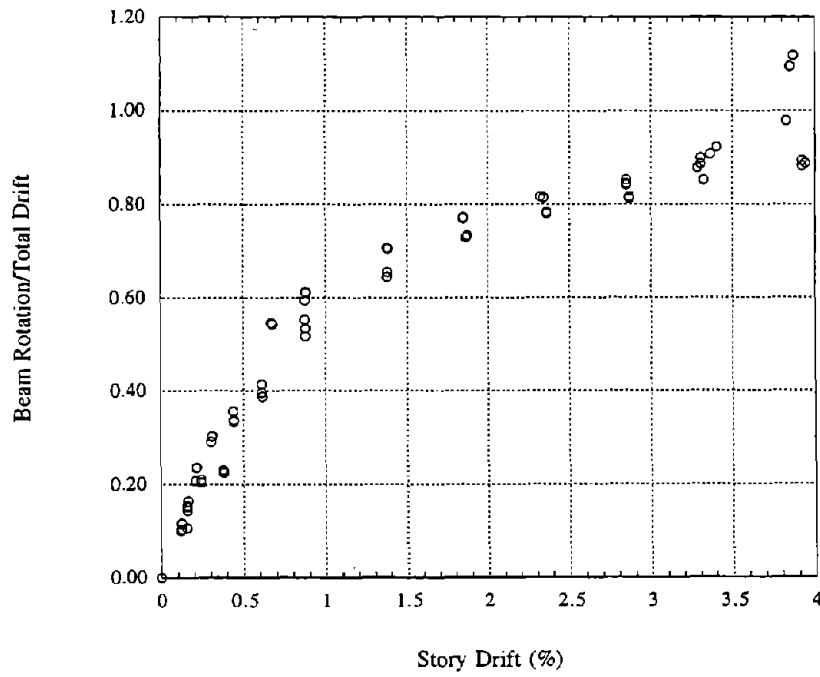

Figure A8. Comparison of Rotation (θ) at the Beam-Column Joint to Connection Rotation, O-P-Z4.

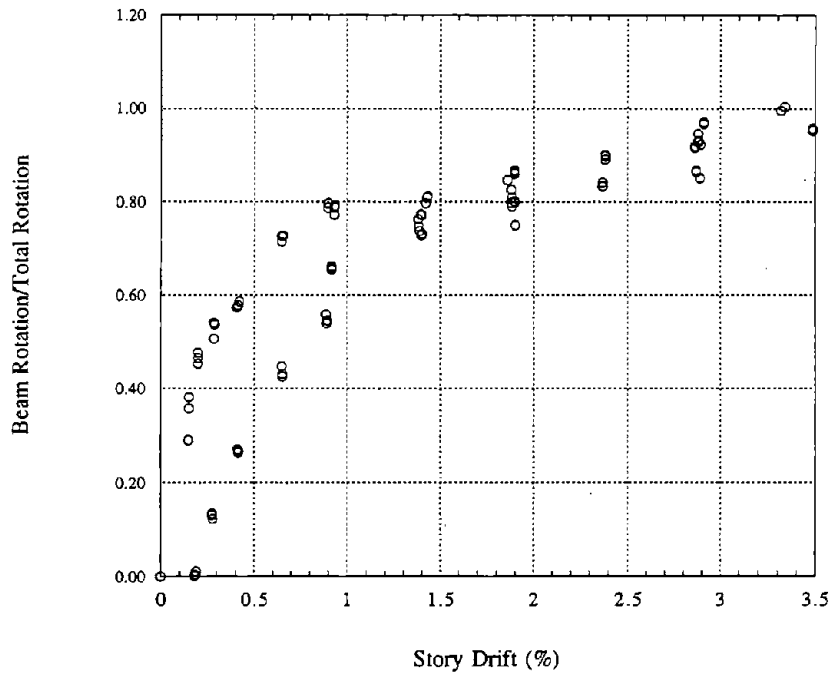

Figure A9. Comparison of Rotation (θ) at the Beam-Column Joint to Connection Rotation, P-P-Z4.

APPENDIX B: PROPOSED ICBO ACCEPTANCE CRITERIA

PROPOSED ACCEPTANCE CRITERIA FOR HYBRID CONNECTIONS IN PRECAST CONCRETE SPECIAL MOMENT RESISTING FRAMES

1 1. INTRODUCTION

2 Scope: The Acceptance Criteria for Hybrid Connections in Precast Concrete Special
3 Moment Resisting Frames (PC-SMRF) shall encompass both strength and deformation capacity
4 in order to qualify as a PC-SMRF with an $R_w=12$ as required in Seismic Zones 3 and 4
5 by Section 1631.2.7 of the 1994 Uniform Building Code. These criteria apply to the connections between
6 the beams and columns in the frame. The design and construction of these beams and columns must
7 comply with applicable portions of the code.

8 2. BASIC INFORMATION

9 2.1 Description: A detailed description of the connectors, including dimensions,
10 materials, and drawings is needed. Evidence of compliance with physical properties must be furnished.

11 2.2 Installation Instructions: Instructions describing placement and inspection are
12 needed.

13 2.3 Design: Structural design and analysis calculations are needed.

14 3. TESTING

15 3.1 General: Specimen sampling, preparation, testing, and reporting shall be
16 performed by an ICBO ES or NES recognized testing laboratory. The test report shall conform
17 to the ICBO ES Acceptance Criteria for Test Reports.

19 3.2 Test Method: A subassembly, at least 1/3 scale, shall be subjected to increasing

20 cyclic displacements. The test apparatus shall be operated in a displacement control mode. Displacements
21 may be applied by means of hydraulic or mechanical actuators or other acceptable means. A calibrated
22 load cell shall be used to measure the load required to produce the prescribed displacements. The rate
23 of loading may be slow and the loading and unloading phases must be continuous without intermittent
24 stops and pauses. Starting at an estimated drift less than first yield, at least three cycles at each
25 displacement level shall be used to evaluate strength and stiffness degradation. The load and displacement
26 readings at the top of the column shall be recorded continuously using digital or analog recorders. Each
27 new displacement level shall not be more than 50 percent greater than the previous displacement level.
28 The subassembly configuration shall be chosen so that its behavior is representative of the expected
29 behavior of the frame. As a minimum, a beam column assembly (cruciform) extending to the anticipated
30 inflection points of the beams and column will be tested.

31 4. CONDITIONS OF ACCEPTANCE

32 4.1 Strength: The maximum strength of the system shall be at least as great as the nominal axial
33 load, moment and shear strength (P_n , M_n , and V_n) calculated according to Sections 7 and 8 of the design
34 procedure for hybrid connections. The moment capacity of the system shall be no greater than λ_0 times
35 the calculated nominal moment. The overstrength factor, λ_0 , is dependent on the system and considers
36 overstrength characteristics of the yielding material, with a minimum value of 1.25.

37 4.2 Deformation: The system shall have the ability to deform to a story drifts of 1.5%, 3.5%, and
38 4.0% for UBC soil types 1, 2, and 3, respectively, while retaining at least 80 percent of the maximum
39 strength achieved during the preceding cycles.

40 5. QUALITY CONTROL

41 A quality control program documented in a manual complying with the Acceptance
42 Criteria for Quality Control Manuals is needed. The quality control agency must have an ICBO
43 ES or NES evaluation report.

APPENDIX C: TYPICAL STRESS-STRAIN CURVES FOR STEEL

1. Representative stress-strain curve for Grade 60 Reinforcing Bars.

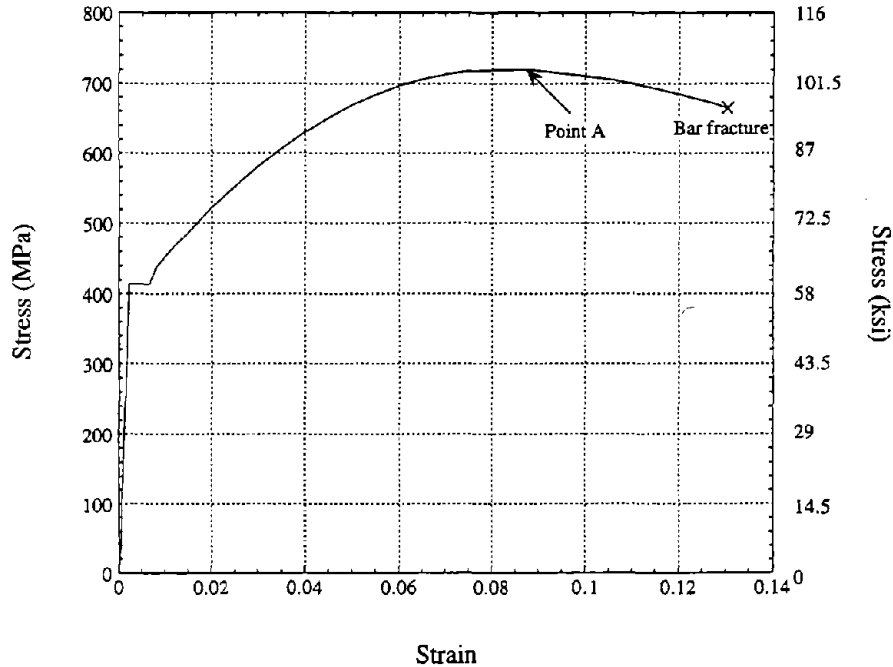

Figure C1. Representative Stress-Strain Curve for Grade 60 Bars.

The curve shown in Figure C1 is taken from Winter and Nilson [1972] for ASTM 615, Grade 60 reinforcing bar and is given because this was the type of steel used in the NIST tests. See Page 25 Section C7.3.3, Step 1, A for additional notes.

2. Analytic stress-strain curve for Grade 270 PT Strands [Mattock, 1979].

$$f_s = \epsilon E \left\{ 0.020 + \frac{0.98}{\left[1 + \left(\frac{\epsilon E}{1.04 f_{py}} \right)^{8.36} \right]^{\frac{1}{8.36}}} \right\}$$

where

$$E = 193\,060 \text{ MPa (28\,000 ksi)}$$

$$f_{py} = 0.9 f_{pu}$$

Preceding Page Blank

The constants in Mattock's equation were solved by using a value of 1.04 for K and an ultimate PT steel strain of 0.04. The stress-strain curve using the above equation is shown in Figure C2.

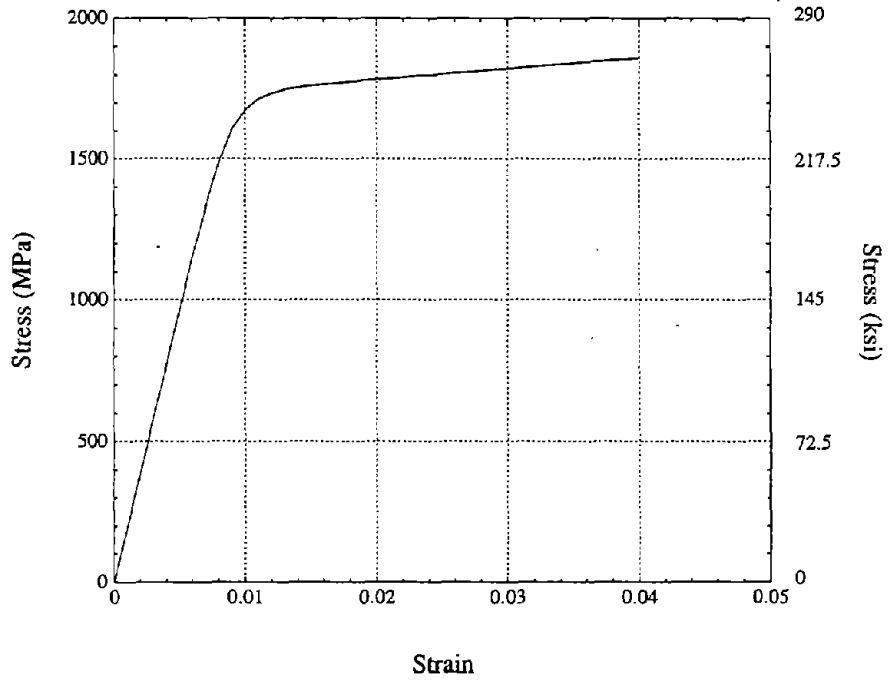

Figure C2. Stress-strain Curve for Grade 270 PT Strand.

APPENDIX D: SAMPLE CALCULATIONS FOR NIST SPECIMENS
 Probable Moment Strength, Drift Capacity, and Nominal Moment Capacity
 (Calculations in SI units followed by calculations in inch-pound units)

JOB NAME: M-P-Z4

GEOMETRY

MATERIAL PROPERTIES

$$\begin{aligned}
 b &:= 8 \cdot (25.4) \cdot \text{mm} & d_b &:= 9.5 \cdot \text{mm} & F_{pu} &:= 270 \cdot (6.895) \cdot \text{MPa} & f_c &:= 7.33 \cdot (6.895) \cdot \text{MPa} \\
 h &:= 16 \cdot (25.4) \cdot \text{mm} & d &:= h - 25.4 \cdot \text{mm} & F_{py} &:= 0.9 \cdot F_{pu} & \beta_1 &:= .85 - 0.05 \cdot \frac{f_c - 27.58 \cdot \text{MPa}}{1 \cdot (6.895) \cdot \text{MPa}} \\
 & & & & F_y &:= 60 \cdot (6.895) \cdot \text{MPa} & \beta_1 &= 0.684
 \end{aligned}$$

$$\begin{aligned}
 A_{ps} &:= 0.459 \cdot (25.4)^2 \cdot \text{mm}^2 & A_s &:= 0.22 \cdot (25.4)^2 \cdot \text{mm}^2 & E_s &:= 29000 \cdot (6.895) \cdot \text{MPa} \\
 A_{ps} &= 296.128 \cdot \text{mm}^2 & A_s &= 141.935 \cdot \text{mm}^2 & E_{ps} &:= 28000 \cdot (6.895) \cdot \text{MPa} \\
 L_{ups} &:= 29 \cdot (25.4) \cdot \text{mm} & L_u &:= 2 \cdot (25.4) \cdot \text{mm} & \epsilon_u &:= 0.088
 \end{aligned}$$

INITIAL CONDITION

$$\begin{aligned}
 V_u &:= 20 \cdot \text{kN} & \mu &:= 1.0 & f_{psi} &:= .44 \cdot F_{pu} \\
 \epsilon_{si} &:= \frac{f_{psi}}{E_{ps}} & \epsilon_{si} &= 0.004 & f_{psi} &= 819.126 \cdot \text{MPa} \\
 f_c &:= \frac{f_{psi} \cdot A_{ps}}{b \cdot h} & f_c &= 3 \cdot \text{MPa}
 \end{aligned}$$

Check clamping force.

$$\begin{aligned}
 \phi &:= 0.85 \\
 \phi \cdot f_{psi} \cdot A_{ps} &> \frac{V_u}{\mu} = 1 & 0 &= n.g. \\
 & & 1 &= ok
 \end{aligned}$$

PLASTIC MOMENT CAPACITY

$$\epsilon_s := \epsilon_u \quad f_u := 105 \cdot (6.895) \cdot \text{MPa}$$

$$T_s := A_s \cdot f_u \quad T_s = 103 \cdot \text{kN}$$

$$\Delta_s := \epsilon_s \cdot (L_u + 5.5 \cdot d_b) \quad \Delta_s = 9.068 \cdot \text{mm}$$

$$\text{assume } c := 3.79 \cdot (25.4) \cdot \text{mm} \quad c = 96.266 \cdot \text{mm}$$

$$\Delta_{ps} := \frac{\frac{h}{2} - c}{d - c} \cdot \Delta_s \quad \Delta_{ps} = 3.406 \cdot \text{mm}$$

$$\epsilon_{ps} := \frac{\Delta_{ps}}{L_{ups}} + \epsilon_{si} \quad \epsilon_{ps} = 0.00887$$

$$Q := 0.01992 \quad R := 8.359758 \quad K := 1.04$$

$$f_{ps} := \epsilon_{ps} \cdot E_{ps} \cdot \left[Q + \frac{1 - Q}{\left[1 + \left(\frac{\epsilon_{ps} \cdot E_{ps}}{K \cdot F_{py}} \right)^R \right]^{\frac{1}{R}}} \right]$$

*PT stress-strain curve proposed
by Alan Mattock [Mattock, 1979]*

$$f_{ps} = 2 \cdot 10^3 \cdot \text{MPa} \quad \frac{f_{ps}}{F_{pu}} = 85\% \quad \text{must be less than } 90\%$$

$$T_{ps} := A_{ps} \cdot f_{ps} \quad T_{ps} = 471 \cdot \text{kN}$$

$$C := T_s + T_{ps} \quad C = 574 \cdot \text{kN}$$

$$c := \frac{C}{0.85 \cdot f_c \cdot b \cdot \beta_1} \quad c = 96.21 \cdot \text{mm} \quad \text{iterate until "c" converges}$$

$$M_s := T_s \cdot \left(d - \frac{\beta_1 \cdot c}{2} \right) \quad M_s = 36 \cdot \text{kN} \cdot \text{m}$$

$$M_{ps} := T_{ps} \cdot \left(\frac{h}{2} - \frac{\beta_1 \cdot c}{2} \right) \quad M_{ps} = 80 \cdot \text{kN} \cdot \text{m}$$

$$M_p := M_s + M_{ps} \quad M_p = 116.04 \cdot \text{kN} \cdot \text{m} \quad \frac{M_s}{M_p} = 0.31 < 0.5 \quad \text{OK}$$

DRIFT CAPACITY @ MAXIMUM MILD STEEL STRAIN

$$\theta := \frac{\Delta_s}{d - c}$$

$$\theta = 3.2\%$$

NOMINAL MOMENT CAPACITY

$$\epsilon_{sh} := 0.01 \quad \text{strain @ onset of strain hardening}$$

$$T_s := A_s \cdot F_y \quad T_s = 58.7 \cdot \text{kN}$$

$$\Delta_s := \epsilon_{sh} \cdot L_u \quad \Delta_s = 0.508 \cdot \text{mm}$$

$$\text{assume } c := 2.105 \cdot (25.4) \cdot \text{mm} \quad c = 53.467 \cdot \text{mm}$$

$$\Delta_{ps} := \frac{\frac{h}{2} - c}{d - c} \cdot \Delta_s \quad \Delta_{ps} = 0.232 \cdot \text{mm}$$

$$\epsilon_{ps} := \frac{\Delta_{ps}}{L_{ups}} + \epsilon_{si} \quad \epsilon_{ps} = 0.00456$$

$$f_{ps} := \epsilon_{ps} \cdot E_{ps} \cdot \left[Q + \frac{1 - Q}{\left[1 + \left(\frac{\epsilon_{ps} \cdot E_{ps}}{K \cdot F_{py}} \right)^R \right]^{\frac{1}{R}}} \right]$$

*PT stress-strain curve proposed
by Alan Mattock [Mattock, 1979]*

$$f_{ps} = 880 \cdot \text{MPa} \quad \frac{f_{ps}}{F_{pu}} = 47\%$$

$$T_{ps} := A_{ps} \cdot f_{ps} \quad T_{ps} = 260.5 \cdot \text{kN}$$

$$C := T_s + T_{ps} \quad C = 319 \cdot \text{kN}$$

$$c := \frac{C}{0.85 \cdot f_c \cdot b \cdot \beta_1} \quad c = 53.50 \cdot \text{mm} \quad \text{iterate until "c" converges}$$

$$M_n := T_s \cdot \left[d - \frac{(\beta_1 \cdot c)}{2} \right] + T_{ps} \cdot \left(\frac{h}{2} - \frac{\beta_1 \cdot c}{2} \right)$$

$$M_n = 69.47 \cdot \text{kN} \cdot \text{m}$$

JOB NAME: O-P-Z4

GEOMETRY

$$b := 203.2 \cdot \text{mm} \quad d_b := 0.375 \cdot (25.4) \cdot \text{mm}$$

$$h := 406.4 \cdot \text{mm} \quad d := h - 1 \cdot (25.4) \cdot \text{mm}$$

$$A_{ps} := 296.1 \cdot \text{mm}^2$$

$$L_{ups} := 29 \cdot (25.4) \cdot \text{mm}$$

$$A_s := 212.903 \cdot \text{mm}^2$$

$$L_u := 2 \cdot (25.4) \cdot \text{mm}$$

MATERIAL PROPERTIES

$$F_{pu} := 270 \cdot (6.895) \cdot \text{MPa}$$

$$f_c := 7.66 \cdot (6.895) \cdot \text{MPa}$$

$$F_{py} := 0.9 \cdot F_{pu}$$

$$\beta_1 := .85 - 0.05 \cdot \frac{f_c - 27.58 \cdot \text{MPa}}{1 \cdot (6.895) \cdot \text{MPa}}$$

$$F_y := 60 \cdot (6.895) \cdot \text{MPa}$$

$$\beta_1 = 0.667$$

$$E_s := 29000 \cdot (6.895) \cdot \text{MPa}$$

$$E_{ps} := 28000 \cdot (6.895) \cdot \text{MPa}$$

$$\varepsilon_u := 0.088$$

INITIAL CONDITION

$$V_u := 20 \cdot \text{kN}$$

$$\mu := 1.0$$

$$f_{psi} := .44 \cdot F_{pu}$$

$$f_{psi} = 819.13 \cdot \text{MPa}$$

$$\varepsilon_{si} := \frac{f_{psi}}{E_{ps}}$$

$$\varepsilon_{si} = 0.0042$$

Check clamping force.

$$f_c := \frac{f_{psi} \cdot A_{ps}}{b \cdot h}$$

$$f_c = 2.9 \cdot \text{MPa}$$

$$\phi := 0.85$$

$$\phi \cdot f_{psi} \cdot A_{ps} > \frac{V_u}{\mu} = 1$$

0=n.g

1=ok

PLASTIC MOMENT CAPACITY

$$\varepsilon_s := \varepsilon_u \quad f_u := 105 \cdot (6.895) \cdot \text{MPa}$$

$$T_s := A_s \cdot f_u \quad T_s = 154 \cdot \text{kN}$$

$$\Delta_s := \varepsilon_s \cdot (L_u + 5.5 \cdot d_b) \quad \Delta_s = 9.08 \cdot \text{mm}$$

assume $c := 4.02 \cdot (25.4) \cdot \text{mm} \quad c = 102.11 \cdot \text{mm}$

$$\Delta_{ps} := \frac{\frac{h}{2} - c}{d - c} \cdot \Delta_s \quad \Delta_{ps} = 3.291 \cdot \text{mm}$$

$$\varepsilon_{ps} := \frac{\Delta_{ps}}{L_{ups}} + \varepsilon_{si} \quad \varepsilon_{ps} = 0.00871$$

$$Q := 0.01992 \quad R := 8.359758 \quad K := 1.04$$

$$f_{ps} := \varepsilon_{ps} \cdot E_{ps} \cdot \left[Q + \frac{1 - Q}{\left[1 + \left(\frac{\varepsilon_{ps} \cdot E_{ps}}{K \cdot F_{py}} \right)^R \right]^{\frac{1}{R}}} \right]$$

*PT stress-strain curve proposed
by Alan Mattock [Mattock, 1979]*

$$f_{ps} = 2 \cdot 10^3 \cdot \text{MPa} \quad \frac{f_{ps}}{F_{pu}} = 85\% \quad \text{must be less than } 90\%$$

$$T_{ps} := A_{ps} \cdot f_{ps} \quad T_{ps} = 467 \cdot \text{kN}$$

$$C := T_s + T_{ps} \quad C = 621 \cdot \text{kN}$$

$$c := \frac{C}{0.85 \cdot F_c \cdot b \cdot \beta_1} \quad c = 102.02 \cdot \text{mm} \quad \text{iterate until "c" converges}$$

$$M_s := T_s \cdot \left(d - \frac{\beta_1 \cdot c}{2} \right) \quad M_s = 53 \cdot \text{kN} \cdot \text{m}$$

$$M_{ps} := T_{ps} \cdot \left(\frac{h}{2} - \frac{\beta_1 \cdot c}{2} \right) \quad M_{ps} = 79 \cdot \text{kN} \cdot \text{m}$$

$$M_p := M_s + M_{ps} \quad M_p = 132.42 \cdot \text{kN} \cdot \text{m} \quad \frac{M_s}{M_p} = 0.4 < 0.5 \text{ OK}$$

DRIFT CAPACITY @ MAXIMUM MILD STEEL STRAIN

$$\theta := \frac{\Delta_s}{d - c}$$

$$\theta = 3.3\%$$

NOMINAL MOMENT CAPACITY

$$\epsilon_{sh} := 0.01 \quad \text{strain @ onset of strain hardening}$$

$$T_s := A_s \cdot F_y \quad T_s = 88.1 \cdot \text{kN}$$

$$\Delta_s := \epsilon_{sh} \cdot L_u \quad \Delta_s = 0.508 \cdot \text{mm}$$

$$\text{assume } c := 2.254 \cdot (25.4) \cdot \text{mm} \quad c = 57.25 \cdot \text{mm}$$

$$\Delta_{ps} := \frac{\frac{h}{2} - c}{d - c} \cdot \Delta_s \quad \Delta_{ps} = 0.229 \cdot \text{mm}$$

$$\epsilon_{ps} := \frac{\Delta_{ps}}{L_{ups}} + \epsilon_{si} \quad \epsilon_{ps} = 0.00455$$

$$f_{ps} := \epsilon_{ps} \cdot E_{ps} \cdot \left[Q + \frac{1 - Q}{\left[1 + \left(\frac{\epsilon_{ps} \cdot E_{ps}}{K \cdot F_{py}} \right)^R \right]^{\frac{1}{R}}} \right]$$

PT stress-strain curve proposed by Alan Mattock [Mattock, 1979]

$$f_{ps} = 879 \cdot \text{MPa}$$

$$\frac{f_{ps}}{F_{pu}} = 47\%$$

$$T_{ps} := A_{ps} \cdot f_{ps}$$

$$T_{ps} = 260.2 \cdot \text{kN}$$

$$C := T_s + T_{ps}$$

$$C = 348.3 \cdot \text{kN}$$

$$c := \frac{C}{0.85 \cdot f_c \cdot b \cdot \beta_1}$$

$$c = 57.24 \cdot \text{mm} \quad \text{iterate until "c" converges}$$

$$M_n := T_s \cdot \left(d - \frac{h}{2} \right) + C \cdot \left(\frac{h}{2} - \frac{\beta_1 \cdot c}{2} \right) \quad \text{sum moments about } T_{ps}$$

$$M_n = 79.78 \cdot \text{kN} \cdot \text{m}$$

JOB NAME: P-P-Z4

GEOMETRY

$$\begin{aligned}b &:= 203.2 \cdot \text{mm} & d_b &:= 9.5 \cdot \text{mm} \\h &:= 406.4 \cdot \text{mm} & d &:= h - 25.4 \cdot \text{mm} \\A_{ps} &:= 296.1 \cdot \text{mm}^2 & L_{ups} &:= 736.6 \cdot \text{mm} \\A_s &:= 193.5 \cdot \text{mm}^2 & L_u &:= 0.0 \cdot \text{mm}\end{aligned}$$

MATERIAL PROPERTIES

$$\begin{aligned}F_{pu} &:= 270 \cdot (6.895) \cdot \text{MPa} & f_c &:= 7.76 \cdot (6.895) \cdot \text{MPa} \\F_{py} &:= 0.9 \cdot F_{pu} & \beta_1 &:= .85 - 0.05 \cdot \frac{f_c - 27.580 \cdot \text{MPa}}{1 \cdot (6.895) \cdot \text{MPa}} \\F_y &:= 60 \cdot (6.895) \cdot \text{MPa} & \beta_1 &= 0.662 \\E_s &:= 29000 \cdot (6.895) \cdot \text{MPa} \\E_{ps} &:= 28000 \cdot (6.895) \cdot \text{MPa} \\ \varepsilon_u &:= 0.14\end{aligned}$$

INITIAL CONDITION

$$\begin{aligned}V_u &:= 20 \cdot \text{kN} & \mu &:= 1.0 \\ \varepsilon_{si} &:= \frac{f_{psi}}{E_{ps}} & \varepsilon_{si} &= 0.0042 \\ f_c &:= \frac{f_{psi} \cdot A_{ps}}{b \cdot h} & f_c &= 3 \cdot \text{MPa}\end{aligned}$$

$$\begin{aligned}f_{psi} &:= .44 \cdot F_{pu} \\ f_{psi} &= 819.1 \cdot \text{MPa}\end{aligned}$$

Check clamping force.

$$\phi = 0.85$$

$$\phi \cdot f_{psi} \cdot A_{ps} > \frac{V_u}{\mu} = 1.0 \quad \begin{array}{l} 0 = n.g. \\ 1 = ok \end{array}$$

PLASTIC MOMENT CAPACITY

$$\varepsilon_s := \varepsilon_u \quad f_u := 105 \cdot (6.895) \cdot \text{MPa}$$

$$T_s := A_s \cdot f_u \quad T_s = 140 \cdot \text{kN}$$

$$\Delta_s := \varepsilon_s \cdot (L_u + 5.5 \cdot d_b) \quad \Delta_s = 7.3 \cdot \text{mm}$$

$$\text{assume } c := 3.9188 \cdot (25.4) \cdot \text{mm} \quad c = 99.538 \cdot \text{mm}$$

$$\Delta_{ps} := \frac{\frac{h}{2} - c}{d - c} \cdot \Delta_s \quad \Delta_{ps} = 2.7 \cdot \text{mm}$$

$$\varepsilon_{ps} := \frac{\Delta_{ps}}{L_{ups}} + \varepsilon_{si} \quad \varepsilon_{ps} = 0.0079$$

$$Q := 0.01992 \quad R := 8.359758 \quad K := 1.04$$

$$f_{ps} := \varepsilon_{ps} \cdot E_{ps} \cdot \left[Q + \frac{1 - Q}{\left[1 + \left(\frac{\varepsilon_{ps} \cdot E_{ps}}{K \cdot F_{py}} \right)^R \right]^{\frac{1}{R}}} \right]$$

*PT stress-strain curve proposed
by Alan Mattock [Mattock, 1979]*

$$f_{ps} = 1 \cdot 10^3 \cdot \text{MPa} \quad \frac{f_{ps}}{F_{pu}} = 79\% \quad \text{must be less than } 90\%$$

$$T_{ps} := A_{ps} \cdot f_{ps} \quad T_{ps} = 437 \cdot \text{kN}$$

$$C := T_s + T_{ps} \quad C = 577 \cdot \text{kN}$$

$$c := \frac{C}{0.85 \cdot f_c \cdot b \cdot \beta_1} \quad c = 94.303 \cdot \text{mm} \quad \text{iterate until "c" converges}$$

$$M_s := T_s \cdot \left(d - \frac{\beta_1 \cdot c}{2} \right) \quad M_s = 49 \cdot \text{kN} \cdot \text{m}$$

$$M_{ps} := T_{ps} \cdot \left(\frac{h}{2} - \frac{\beta_1 \cdot c}{2} \right) \quad M_{ps} = 75 \cdot \text{kN} \cdot \text{m}$$

$$M_p := M_s + M_{ps} \quad M_p = 124.13 \cdot \text{kN} \cdot \text{m} \quad \frac{M_s}{M_p} = 0.39 < 0.5 \quad \text{OK}$$

DRIFT CAPACITY @ MAXIMUM MILD STEEL STRAIN

$$\theta := \frac{\Delta_s}{d - c}$$

$$\theta = 2.6\%$$

NOMINAL MOMENT CAPACITY

$$\varepsilon_{sh} := 0.01 \quad \text{strain @ onset of strain hardening}$$

$$T_s := A_s \cdot F_y \quad T_s = 80.1 \cdot \text{kN}$$

$$\Delta_s := \varepsilon_{sh} \cdot L_u \quad \Delta_s = 0.0 \cdot \text{mm}$$

$$\text{assume } c := 2.191 \cdot (25.4) \cdot \text{mm} \quad c = 55.651 \cdot \text{mm}$$

$$\Delta_{ps} := \frac{\frac{h}{2} - c}{d - c} \cdot \Delta_s \quad \Delta_{ps} = 0.0 \cdot \text{mm}$$

$$\varepsilon_{ps} := \frac{\Delta_{ps}}{L_{ups}} + \varepsilon_{si} \quad \varepsilon_{ps} = 0.00424$$

$$f_{ps} := \varepsilon_{ps} \cdot E_{ps} \cdot \left[Q + \frac{1 - Q}{\left[1 + \left(\frac{\varepsilon_{ps} \cdot E_{ps}}{K \cdot F_{py}} \right)^R \right]^{\frac{1}{R}}} \right]$$

*PT stress-strain curve proposed
by Alan Mattock [Mattock, 1979]*

$$f_{ps} = 819 \cdot \text{MPa} \quad \frac{f_{ps}}{F_{pu}} = 44\%$$

$$T_{ps} := A_{ps} \cdot f_{ps} \quad T_{ps} = 242.5 \cdot \text{kN}$$

$$C := T_s + T_{ps} \quad C = 323 \cdot \text{kN}$$

$$c := \frac{C}{0.85 \cdot f_c \cdot b \cdot \beta_1} \quad c = 52.722 \cdot \text{mm} \quad \text{iterate until "c" converges}$$

$$M_n := T_s \cdot \left(d - \frac{h}{2} \right) + C \cdot \left(\frac{h}{2} - \frac{\beta_1 \cdot c}{2} \right) \quad \text{sum moments about } T_{ps}$$

$$M_n = 74.15 \cdot \text{kN} \cdot \text{m}$$

CALCULATIONS IN INCH-POUND UNITS

JOB NAME: M-P-Z4

GEOMETRY

$$\begin{aligned}
 b &:= 8 \cdot \text{in} & d_b &:= 0.375 \cdot \text{in} \\
 h &:= 16 \cdot \text{in} & d &:= h - 1 \cdot \text{in} \\
 A_{ps} &:= 3 \cdot 153 \cdot \text{in}^2 & A_s &:= 2 \cdot 0.11 \cdot \text{in}^2 \\
 A_{ps} &= 0.459 \cdot \text{in}^2 & A_s &= 0.220 \cdot \text{in}^2 \\
 L_{ups} &:= 29 \cdot \text{in} & L_u &:= 2 \cdot \text{in}
 \end{aligned}$$

MATERIAL PROPERTIES

$$\begin{aligned}
 F_{pu} &:= 270 \cdot \text{ksi} & f_c &:= 7.33 \cdot \text{ksi} \\
 F_{py} &:= 0.9 \cdot F_{pu} & \beta_1 &:= .85 - 0.05 \cdot \frac{f_c - 4 \cdot \text{ksi}}{1 \cdot \text{ksi}} \\
 F_y &:= 60 \cdot \text{ksi} & \beta_1 &= 0.684 \\
 E_s &:= 29000 \cdot \text{ksi} \\
 E_{ps} &:= 28000 \cdot \text{ksi} \\
 \epsilon_u &:= 0.088
 \end{aligned}$$

INITIAL CONDITION

$$\begin{aligned}
 V_u &:= 4.496 \cdot \text{kip} & \mu &:= 1.0 \\
 \epsilon_{si} &:= \frac{f_{psi}}{E_{ps}} & \epsilon_{si} &= 0.004 \\
 f_c &:= \frac{f_{psi} \cdot A_{ps}}{b \cdot h} & f_c &= 426 \cdot \text{psi}
 \end{aligned}$$

$$\begin{aligned}
 f_{psi} &:= .44 \cdot F_{pu} \\
 f_{psi} &= 118.800 \cdot \text{ksi}
 \end{aligned}$$

Check clamping force.

$$\begin{aligned}
 \phi &:= 0.85 \\
 \phi \cdot f_{psi} \cdot A_{ps} &> \frac{V_u}{\mu} = 1.000 & \begin{array}{l} 0=n.g \\ 1=ok \end{array}
 \end{aligned}$$

PLASTIC MOMENT CAPACITY

$$\epsilon_s := \epsilon_u \quad f_u := 105 \cdot \text{ksi}$$

$$T_s := A_s \cdot f_u \quad T_s = 23 \cdot \text{kip}$$

$$\Delta_s := \epsilon_s \cdot (L_u + 5.5 \cdot d_b) \quad \Delta_s = 0.357 \cdot \text{in}$$

assume $c := 3.79 \cdot \text{in}$

$$\Delta_{ps} := \frac{\frac{h}{2} - c}{d - c} \cdot \Delta_s \quad \Delta_{ps} = 0.134 \cdot \text{in}$$

$$\epsilon_{ps} := \frac{\Delta_{ps}}{L_{ups}} + \epsilon_{si} \quad \epsilon_{ps} = 0.00887$$

$$Q := 0.01992 \quad R := 8.359758 \quad K := 1.04$$

$$f_{ps} := \epsilon_{ps} \cdot E_{ps} \cdot \left[Q + \frac{1 - Q}{\left[1 + \left(\frac{\epsilon_{ps} \cdot E_{ps}}{K \cdot F_{py}} \right)^R \right]^{\frac{1}{R}}} \right]$$

PT stress-strain curve proposed by Alan Mattock [Mattock, 1979]

$$f_{ps} = 231 \cdot \text{ksi} \quad \frac{f_{ps}}{F_{pu}} = 86\% \quad \text{must be less than 90\%}$$

$$T_{ps} := A_{ps} \cdot f_{ps} \quad T_{ps} = 106 \cdot \text{kip}$$

$$C := T_s + T_{ps} \quad C = 129 \cdot \text{kip}$$

$$c := \frac{C}{0.85 \cdot F_c \cdot b \cdot \beta_1} \quad c = 3.789 \cdot \text{in} \quad \text{iterate until "c" converges}$$

$$M_s := T_s \cdot \left(d - \frac{\beta_1 \cdot c}{2} \right) \quad M_s = 26 \cdot \text{kip} \cdot \text{ft}$$

$$M_{ps} := T_{ps} \cdot \left(\frac{h}{2} - \frac{\beta_1 \cdot c}{2} \right) \quad M_{ps} = 59 \cdot \text{kip} \cdot \text{ft}$$

$$M_p := M_s + M_{ps} \quad M_p = 85.60 \cdot \text{kip} \cdot \text{ft} \quad \frac{M_s}{M_p} = 0.31 < 0.5 \quad \text{OK}$$

DRIFT CAPACITY @ MAXIMUM MILD STEEL STRAIN

$$\theta = \frac{\Delta_s}{d - c}$$

$$\theta = 3.2\%$$

NOMINAL MOMENT CAPACITY

$$\epsilon_{sh} := 0.01 \quad \text{Strain @ onset of strain hardening}$$

$$T_s := A_s \cdot F_y \quad T_s = 13.2 \cdot \text{kip}$$

$$\Delta_s := \epsilon_{sh} \cdot L_u \quad \Delta_s = 0.020 \cdot \text{in}$$

assume $c := 1.987 \cdot \text{in}$

$$\Delta_{ps} := \frac{\frac{h}{2} - c}{d - c} \cdot \Delta_s \quad \Delta_{ps} = 0.009 \cdot \text{in}$$

$$\epsilon_{ps} := \frac{\Delta_{ps}}{L_{ups}} + \epsilon_{si} \quad \epsilon_{ps} = 0.00456$$

$$f_{ps} := \epsilon_{ps} \cdot E_{ps} \cdot \left[Q + \frac{1 - Q}{\left[1 + \left(\frac{\epsilon_{ps} \cdot E_{ps}}{K \cdot F_{py}} \right)^R \right]^{\frac{1}{R}}} \right]$$

PT stress-strain curve proposed by Alan Mattock [Mattock, 1979]

$$f_{ps} = 128 \cdot \text{ksi} \quad \frac{f_{ps}}{F_{pu}} = 47\%$$

$$T_{ps} := A_{ps} \cdot f_{ps} \quad T_{ps} = 58.6 \cdot \text{kip}$$

$$C := T_s + T_{ps} \quad C = 72 \cdot \text{kip}$$

$$c := \frac{C}{0.85 \cdot f_c \cdot b \cdot \beta_1} \quad c = 2.108 \cdot \text{in} \quad \text{iterate until "c" converges}$$

$$M_n := T_s \cdot \left[d - \frac{(\beta_1 \cdot c)}{2} \right] + T_{ps} \cdot \left(\frac{h}{2} - \frac{\beta_1 \cdot c}{2} \right) \quad \text{sum moments about } T_{ps}$$

$$M_n = 51.26 \cdot \text{kip} \cdot \text{ft}$$

JOB NAME: O-P-Z4

GEOMETRY

$$\begin{aligned} b &:= 8 \cdot \text{in} & d_b &:= 0.375 \cdot \text{in} \\ h &:= 16 \cdot \text{in} & d &:= h - 1 \cdot \text{in} \\ A_{ps} &:= 3 \cdot .153 \cdot \text{in}^2 & A_s &:= 3 \cdot 0.11 \cdot \text{in}^2 \\ A_{ps} &= 0.459 \cdot \text{in}^2 & A_s &= 0.330 \cdot \text{in}^2 \\ L_{ups} &:= 29 \cdot \text{in} & L_u &:= 2 \cdot \text{in} \end{aligned}$$

MATERIAL PROPERTIES

$$\begin{aligned} F_{pu} &:= 270 \cdot \text{ksi} & f_c &:= 7.66 \cdot \text{ksi} \\ E_{py} &:= 0.9 \cdot F_{pu} & \beta_1 &:= .85 - 0.05 \cdot \frac{f_c - 4 \cdot \text{ksi}}{1 \cdot \text{ksi}} \\ F_y &:= 60 \cdot \text{ksi} & \beta_1 &= 0.667 \\ E_s &:= 29000 \cdot \text{ksi} & E_c &:= 57 \cdot \sqrt{\frac{f_c}{\text{ksi}}} \cdot 1000 \cdot \text{ksi} \\ E_{ps} &:= 28000 \cdot \text{ksi} & E_c &= 4989 \cdot \text{ksi} \\ \epsilon_u &:= 0.088 \end{aligned}$$

INITIAL CONDITION

$$\begin{aligned} V_u &:= 4.496 \cdot \text{kip} & \mu &:= 1.0 & f_{psi} &:= .44 \cdot F_{pu} & f_{psi} &= 118.800 \cdot \text{ksi} \\ \epsilon_{si} &:= \frac{f_{psi}}{E_{ps}} & \epsilon_{si} &= 0.0042 & & & & \\ f_c &:= \frac{f_{psi} \cdot A_{ps}}{b \cdot h} & f_c &= 426 \cdot \text{psi} & \phi &:= 0.85 \end{aligned}$$

Check clamping force.

$$\phi \cdot f_{psi} \cdot A_{ps} > \frac{V_u}{\mu} = 1.000 \quad \begin{matrix} 0=n.g. \\ 1=ok \end{matrix}$$

PLASTIC MOMENT CAPACITY

$$\epsilon_s := \epsilon_u$$

$$f_u := 105 \cdot \text{ksi}$$

$$T_s := A_s \cdot f_u$$

$$T_s = 35 \cdot \text{kip}$$

$$\Delta_s := \epsilon_u \cdot (L_u + 5.5 \cdot d_b)$$

$$\Delta_s = 0.357 \cdot \text{in}$$

assume $c := 4.018 \cdot \text{in}$

$$\Delta_{ps} := \frac{\frac{h}{2} - c}{d - c} \cdot \Delta_s \quad \Delta_{ps} = 0.130 \cdot \text{in}$$

$$\epsilon_{ps} := \frac{\Delta_{ps}}{L_{ups}} + \epsilon_{si} \quad \epsilon_{ps} = 0.00871$$

$$Q := 0.01992 \quad R := 8.359758 \quad K := 1.04$$

$$f_{ps} := \epsilon_{ps} \cdot E_{ps} \cdot \left[Q + \frac{1 - Q}{\left[1 + \left(\frac{\epsilon_{ps} \cdot E_{ps}}{K \cdot F_{py}} \right)^R \right]^{\frac{1}{R}}} \right]$$

*PT stress-strain curve proposed
by Alan Mattock [Mattock, 1979]*

$$f_{ps} = 228.559 \cdot \text{ksi}$$

$$\frac{f_{ps}}{F_{pu}} = 85\% \quad \text{must be less than 90\%}$$

$$T_{ps} := A_{ps} \cdot f_{ps}$$

$$T_{ps} = 105 \cdot \text{kip}$$

$$C := T_s + T_{ps}$$

$$C = 140 \cdot \text{kip}$$

$$c := \frac{C}{0.85 \cdot f_c \cdot b \cdot \beta_1}$$

$$c = 4.017 \cdot \text{in} \quad \text{iterate until "c" converges}$$

$$M_s := T_s \cdot \left(d - \frac{\beta_1 \cdot c}{2} \right)$$

$$M_s = 39 \cdot \text{kip} \cdot \text{ft}$$

$$M_{ps} := T_{ps} \cdot \left(\frac{h}{2} - \frac{\beta_1 \cdot c}{2} \right)$$

$$M_{ps} = 58 \cdot \text{kip} \cdot \text{ft}$$

$$M_p := M_s + M_{ps}$$

$$M_p = 97.67 \cdot \text{kip} \cdot \text{ft}$$

$$\frac{M_s}{M_p} = 0.4 < 0.5 \quad \text{OK}$$

DRIFT CAPACITY @ MAXIMUM MILD STEEL STRAIN

$$\theta := \frac{\Delta_s}{d - c}$$

$$\theta = 3.3\%$$

NOMINAL MOMENT CAPACITY

$$\varepsilon_{sh} := 0.010 \quad \text{Strain @ onset of strain hardening}$$

$$T_s := A_s \cdot F_y \quad T_s = 19.8 \cdot \text{kip}$$

$$\Delta_s := \varepsilon_{sh} \cdot L_u \quad \Delta_s = 0.020 \cdot \text{in}$$

assume $c := 2.254 \cdot \text{in}$

$$\Delta_{ps} := \frac{\frac{h}{2} - c}{d - c} \cdot \Delta_s \quad \Delta_{ps} = 0.0090 \cdot \text{in}$$

$$\varepsilon_{ps} := \frac{\Delta_{ps}}{L_{ups}} + \varepsilon_{si} \quad \varepsilon_{ps} = 0.00455$$

$$f_{ps} := \varepsilon_{ps} \cdot E_{ps} \cdot \left[Q + \frac{1 - Q}{\left[1 + \left(\frac{\varepsilon_{ps} \cdot E_{ps}}{K \cdot F_{py}} \right)^R \right]^{\frac{1}{R}}} \right]$$

PT stress-strain curve proposed by Alan Mattock [Mattock, 1979]

$$f_{ps} = 127 \cdot \text{ksi}$$

$$\frac{f_{ps}}{F_{pu}} = 47\%$$

$$T_{ps} := A_{ps} \cdot f_{ps}$$

$$T_{ps} = 58.5 \cdot \text{kip}$$

$$C := T_s + T_{ps}$$

$$C = 78.3 \cdot \text{kip}$$

$$c := \frac{C}{0.85 \cdot f'_c \cdot b \cdot \beta_1}$$

$$c = 2.254 \cdot \text{in} \quad \text{iterate until "c" converges}$$

$$M_n := T_s \cdot \left(d - \frac{h}{2} \right) + C \cdot \left(\frac{h}{2} - \frac{\beta_1 \cdot c}{2} \right)$$

sum moments about T_{ps}

$$M_n = 58.85 \cdot \text{kip} \cdot \text{ft}$$

JOB NAME: P-P-Z4

GEOMETRY

$b := 8 \cdot \text{in}$ $d_b := 0.375 \cdot \text{in}$

$h := 16 \cdot \text{in}$ $d := h - 1 \cdot \text{in}$

$A_{ps} := 3 \cdot .153 \cdot \text{in}^2$ $A_s := 3 \cdot 0.10 \cdot \text{in}^2$

$A_{ps} = 0.459 \cdot \text{in}^2$ $A_s = 0.3 \cdot \text{in}^2$

$L_{ups} := 29 \cdot \text{in}$ $L_u := 0 \cdot \text{in}$

MATERIAL PROPERTIES

$F_{pu} := 270 \cdot \text{ksi}$ $f_c := 7.76 \cdot \text{ksi}$

$F_{py} := 0.9 \cdot F_{pu}$ $\beta_1 := .85 - 0.05 \cdot \frac{f_c - 4 \cdot \text{ksi}}{1 \cdot \text{ksi}}$

$F_y := 60 \cdot \text{ksi}$ $\beta_1 = 0.662$

$E_s := 29000 \cdot \text{ksi}$

$E_{ps} := 28000 \cdot \text{ksi}$

$\epsilon_u := 0.14$

INITIAL CONDITION

$V_u := 4.496 \cdot \text{kip}$

$\mu := 1.0$

$f_{psi} := .44 \cdot F_{pu}$

$f_{psi} = 118.8 \cdot \text{ksi}$

$\epsilon_{si} := \frac{f_{psi}}{E_{ps}}$

$\epsilon_{si} = 0.004$

Check clamping force.

$f_c := \frac{f_{psi} \cdot A_{ps}}{b \cdot h}$

$f_c = 426 \cdot \text{psi}$

$\phi := 0.85$

$\phi \cdot f_{psi} \cdot A_{ps} > \frac{V_u}{\mu} = 1$

0=n.g.

1=ok

PLASTIC MOMENT CAPACITY

$$\begin{aligned} \epsilon_s &:= \epsilon_u & f_u &:= 105 \cdot \text{ksi} \\ T_s &:= A_s \cdot f_u & T_s &= 31 \cdot \text{kip} \\ \Delta_s &:= \epsilon_s \cdot (L_u + 5.5 \cdot d_b) & \Delta_s &= 0.289 \cdot \text{in} \end{aligned}$$

assume $c := 3.919 \cdot \text{in}$

$$\Delta_{ps} := \frac{\frac{h}{2} - c}{d - c} \cdot \Delta_s \quad \Delta_{ps} = 0.106 \cdot \text{in}$$

$$\epsilon_{ps} := \frac{\Delta_{ps}}{L_{ups}} + \epsilon_{si} \quad \epsilon_{ps} = 0.00791$$

$$Q := 0.019924 \quad K := 1.04 \quad R := 8.359758$$

$$f_{ps} := \epsilon_{ps} \cdot E_{ps} \cdot \left[Q + \frac{1 - Q}{\left[1 + \left(\frac{\epsilon_{ps} \cdot E_{ps}}{K \cdot F_{py}} \right)^R \right]^{\frac{1}{R}}} \right]$$

PT stress-strain curve proposed by Alan Mattock [Mattock, 1979]

$$f_{ps} = 214 \cdot \text{ksi} \quad \frac{f_{ps}}{F_{pu}} = 79\% \quad \text{must be less than 90\%}$$

$$T_{ps} := A_{ps} \cdot f_{ps} \quad T_{ps} = 98 \cdot \text{kip}$$

$$C := T_s + T_{ps} \quad C = 130 \cdot \text{kip}$$

$$c := \frac{C}{0.85 \cdot f_c \cdot b \cdot \beta_1} \quad c = 3.716 \cdot \text{in} \quad \text{iterate until "c" converges}$$

$$M_s := T_s \cdot \left(d - \frac{\beta_1 \cdot c}{2} \right) \quad M_s = 36 \cdot \text{kip} \cdot \text{ft}$$

$$M_{ps} := T_{ps} \cdot \left(\frac{h}{2} - \frac{\beta_1 \cdot c}{2} \right) \quad M_{ps} = 55 \cdot \text{kip} \cdot \text{ft}$$

$$M_p := M_s + M_{ps} \quad M_p = 91.61 \cdot \text{kip} \cdot \text{ft} \quad \frac{M_s}{M_p} = 0.39 < 0.5 \quad \text{OK}$$

DRIFT CAPACITY @ MAXIMUM MILD STEEL STRAIN

$$\theta := \frac{\Delta_s}{d - c}$$

$$\theta = 2.6\%$$

NOMINAL MOMENT CAPACITY

$$\epsilon_{sh} := 0.010 \quad \text{strain @ onset of strain hardening}$$

$$T_s := A_s \cdot F_y \quad T_s = 18 \cdot \text{kip}$$

$$\Delta_s := \epsilon_{sh} \cdot L_u \quad \Delta_s = 0 \cdot \text{in}$$

assume $c := 2.191 \cdot \text{in}$

$$\Delta_{ps} := \frac{\frac{h}{2} - c}{d - c} \cdot \Delta_s \quad \Delta_{ps} = 0 \cdot \text{in}$$

$$\epsilon_{ps} := \frac{\Delta_{ps}}{L_{ups}} + \epsilon_{si} \quad \epsilon_{ps} = 0.00424$$

$$f_{ps} := \epsilon_{ps} \cdot E_{ps} \cdot \left[Q + \frac{1 - Q}{\left[1 + \left(\frac{\epsilon_{ps} \cdot E_{ps}}{K \cdot F_{py}} \right)^R \right]^{\frac{1}{R}}} \right]$$

PT stress-strain curve proposed by Alan Mattock [Mattock, 1979]

$$f_{ps} = 119 \cdot \text{ksi}$$

$$\frac{f_{ps}}{F_{pu}} = 44\%$$

$$T_{ps} := A_{ps} \cdot f_{ps}$$

$$T_{ps} = 54.5 \cdot \text{kip}$$

$$C := T_s + T_{ps}$$

$$C = 73 \cdot \text{kip}$$

$$c := \frac{C}{0.85 \cdot f'_c \cdot b \cdot \beta_1}$$

$$c = 2.076 \cdot \text{in} \quad \text{iterate until "c" converges}$$

$$M_n := T_s \cdot \left(d - \frac{h}{2} \right) + C \cdot \left(\frac{h}{2} - \frac{\beta_1 \cdot c}{2} \right) \quad \text{sum moments about } T_{ps}$$

$$M_n = 54.69 \cdot \text{kip} \cdot \text{ft}$$

SUMMARY OF RESULTS: PROBABLE MOMENT

Table D1. Probable Moments

SPECIMEN	M_{pr} Calc. ^a Col. 1 kN-m [k-ft]	M_{pr} Calc. ^b Col. 2 kN-m [k-ft]	$M_{max. exp.}$ Col. 3 kN-m [k-ft]	Col. 1 / Col. 3	Col. 2 / Col. 3
M-P-Z4	113.21 [83.49]	116.07 [85.60]	120.45 [88.83]	0.94	0.96
O-P-Z4	137.28 [101.24]	132.42 [97.67]	141.70 [104.50]	0.97	0.93
P-P-Z4	125.28 [92.39]	124.13 [91.61]	133.84 [98.70]	0.94	0.93

- a Using actual ultimate stress for mild steel as obtained from tension tests and measured unbonded length.
 b Using ultimate steel stress as obtained from a typical σ - ϵ curve and unbonded length based on empirical equation. $L_u = L_u + 5.5 d_u$. Calculation procedure shown in Appendix D.

The moment contribution from the mild steel in compression was not accounted for in the calculation of M_{pr} . The calculated probable moments using the procedures described in Section 7 (Column 2) ranged between 4 to 7 percent below the experimental maximum moment (Column 3).

SUMMARY OF RESULTS: NOMINAL MOMENT

Table D2. Comparison of M_n , M_y and M_{pr} .

SPECIMEN	M_n kN-m [k-ft]	$M_{y \text{ exp.}}$ kN-m [k-ft]	$M_{pr \text{ Calc.}}^a$ kN-m [k-ft]	$M_{\text{max. exp.}}$ kN-m [k-ft]	Col. 2 / Col. 4 M_n/M_{pr}	Col. 3 / Col. 4 M_y/M_{pr}	Col. 3 / Col. 5 M_y/M_{max}
	Col. 2	Col. 3	Col. 4	Col. 5	Col. 6	Col. 7	Col. 8
M-P-Z4	69.47 [51.23]	88.00 [64.90]	116.07 [85.60]	120.45 [88.83]	0.60	0.76	0.73
O-P-Z4	79.79 [58.85]	97.14 [71.64]	132.42 [97.67]	141.70 [104.50]	0.60	0.73	0.69
P-P-Z4	77.14 [56.89]	94.72 [69.85]	124.13 [91.61]	133.84 [98.70]	0.62	0.76	0.71

a Using ultimate steel stress as obtained from a typical σ - ϵ curve and unbonded length based on empirical equation. $L_u = L_e + 5.5 d_b$. Calculation procedure shown in Appendix D.

As can be seen in Column 6, the calculated nominal moment is $0.6 M_{pr}$, whereas the experimentally determined yield moment was approximately $0.7 M_{pr}$ (Column 7). The calculated nominal moments are on average about 20% lower than the experimentally obtained "yield" moments. This is a direct consequence of arbitrarily setting the mild steel strain at $\epsilon_{sh} = 0.01$ and higher actual material strengths.

The notation for the variables in Table D2 are as follows:

- M_n Nominal moment values as calculated following the procedure outlined in Section 8. Column 2.
- $M_{y \text{ exp.}}$ Experimental yield moment. From the hysteresis plot of the test specimens, two yield loads, one in each direction, for the connection were obtained (Figure C1). The yield point is somewhat subjective because there is no sharp change in the slope of the envelope curve. From these values, corresponding beam loads were obtained at "yield". The two beam loads were averaged and a beam moment was calculated, $M_{y \text{ exp}}$ by multiplying this load by the moment arm. Column 3.
- $M_{pr \text{ Calc.}}$ Calculated probable moment, M_{pr} calculated using the design procedure in Section 7.3. Column 4.
- $M_{\text{max exp}}$ Measured maximum experimental beam moments. Column 5.

An alternative for calculating the nominal moment, which produces better correlation with experimentally observed yield moments, would be to allow $f_s = 1.25 f_y$ and obtain the mild steel strain from the stress-strain curve. This permits added rotation which mobilizes a larger post tension force and therefore increases the nominal moment. However, there is a certain utility to retaining simplicity. Should the experimentally observed ratios be considered appropriate (they were very repeatable) then it could be suggested that:

$$M_n = 0.70 M_{pr}$$

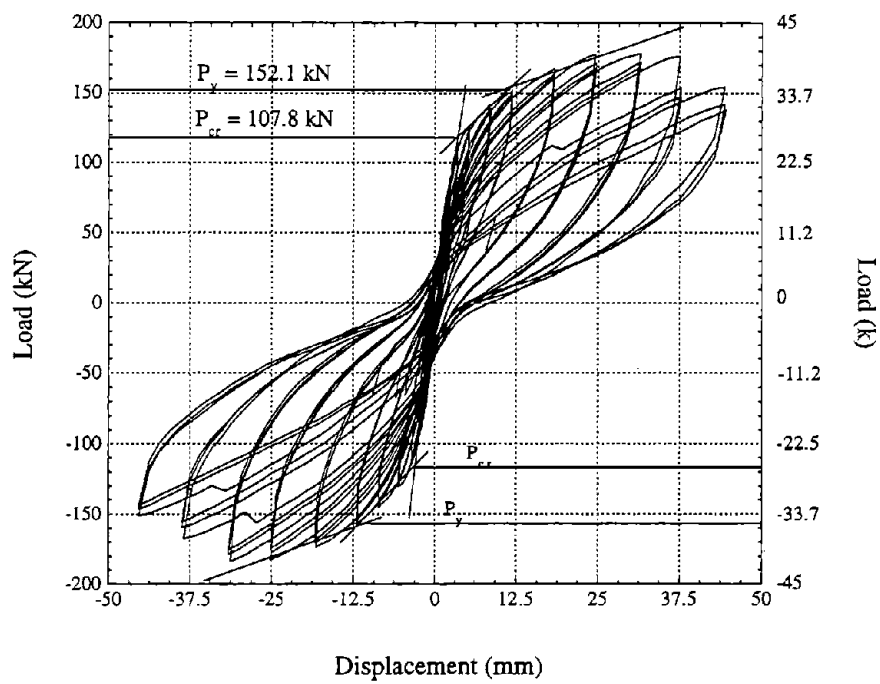

Figure D1. Load Displacement Plot for Specimen M-P-Z4.

APPENDIX E: CALCULATIONS TO ESTIMATE ADDITIONAL DEBONDED LENGTH OF MILD STEEL BARS

NIST SPECIMEN M-P-Z4:

$b = 203.2 \text{ mm}$ [8 in.]	$f_u = 672.8 \text{ MPa}$ [97.58 ksi]
$h = 406.4 \text{ mm}$ [16 in.]	$f_{pc} = 0.44 f_{pu}$
$d = 381.0 \text{ mm}$ [15 in.]	$A_s = 141.9 \text{ mm}^2$ [0.22 in ²] - 2 #3
$d_b = 9.5 \text{ mm}$ [0.375 in.]	$A_{ps} = 296.1 \text{ mm}^2$ [0.459 in ²]
$d_p = 203.2 \text{ mm}$ [8 in.]	$L_u = 50.8 \text{ mm}$ [2 in.] for mild bars
$f'_c = 50.5 \text{ MPa}$ [7.33 ksi]	$L_{u ps} = 736.6 \text{ mm}$ [29 in.] for PT steel

1. Calculate T_s

$$T_s = A_s f_u = 141.9 \text{ mm}^2 (672.8 \text{ MPa}) = 95.47 \text{ kN} [21.46 \text{ k}]$$

$$f_u = 672.8 \text{ MPa} [97.58 \text{ ksi}] \text{ from tension tests of bars.}$$

2. Calculate elongation of mild steel, Δ_s

Assume $\epsilon_u \approx 0.088$ from Figure C1.

$$\Delta_s = \epsilon_u L_u = 0.088 (50.8 \text{ mm}) = 4.47 \text{ mm} [0.18 \text{ in.}]$$

However, the gap between the beam and column that was measured at maximum moment was 8.71 mm [0.343 in.]. Therefore, the effective debonded length, $L_{u \text{ eff}}$ is

$$\begin{aligned} L_{u \text{ eff}} &= 8.71/4.47 L_u \\ &= 1.95 (50.8) = 99.06 \text{ mm} [3.9 \text{ in.}] \end{aligned}$$

$L_{u \text{ eff}} = 99.06 \text{ mm}$ [3.9 in.] suggests an additional debonded length of $(99.06 - 50.8)/2 = 24.13 \text{ mm}$ [0.95 in.] $\approx 2.5 d_b$ on either side of the bar. Where 50.8 mm [2.0 in.] is the specified intentionally unbonded length.

NIST SPECIMEN O-P-Z4

Similar calculations to estimate the debonded length were made for NIST specimen O-P-Z4. Step 2 is shown below:

2. Calculate elongation of mild steel, Δ_s

Assume $\epsilon_u \approx 0.088$ from Figure C1.

$$\Delta_s = \epsilon_u L_u = 0.088 (50.8 \text{ mm}) = 4.47 \text{ mm} [0.18 \text{ in.}]$$

However, the gap between the beam and column that was measured at maximum moment was 9.91 mm [0.39 in.]. Therefore, the effective debonded length, $L_{u \text{ eff}}$ is

$$L_{u \text{ eff}} = 9.91/4.47 L_u$$

$$= 2.21 (50.8) = 112.27 \text{ mm [4.42 in.]}$$

$L_{u \text{ eff}} = 112.27 \text{ mm [4.42 in.]}$ suggests an additional debonded length of $(112.27 - 50.8)/2 = 30.73 \text{ mm [1.21 in.]} \approx 3.2 d_b$ on either side of the bar. Where 50.8 mm [2.0 in.] is the specified intentionally unbonded length.

NIST SPECIMEN P-P-Z4

No attempt was made to estimate the debonded length of the stainless steel bars in specimen P-P-Z4 because of the different deformation pattern of this bar from the previous two specimens.

**APPENDIX F: DETERMINATION OF M_s/M_{pr} RATIO
AT MAXIMUM A_s**

(Calculations in SI units followed by calculations in inch-pound units)

JOB NAME: M-P-Z4. Max. A_s

GEOMETRY

$$b := 8 \cdot (25.4) \cdot \text{mm}$$

$$h := 16 \cdot (25.4) \cdot \text{mm}$$

$$d_p := \frac{h}{2}$$

$$A_{ps} := 0.459 \cdot (25.4)^2 \cdot \text{mm}^2$$

$$A_{ps} = 296.128 \cdot \text{mm}^2$$

$$d_b := 0.375 \cdot (25.4) \cdot \text{mm}$$

$$d := h - 25.4 \cdot \text{mm}$$

$$L_{ups} := 29 \cdot (25.4) \cdot \text{mm}$$

$$L_u := 2 \cdot (25.4) \cdot \text{mm}$$

MATERIAL PROPERTIES

$$F_{pu} := 270 \cdot (6.895) \cdot \text{MPa} \quad f_c := 7.33 \cdot (6.895) \cdot \text{MPa}$$

$$F_{py} := 0.9 \cdot F_{pu} \quad \beta_1 := 0.85 - 0.05 \cdot \frac{f_c - 4 \cdot (6.895) \cdot \text{MPa}}{1 \cdot (6.895) \cdot \text{MPa}}$$

$$F_y := 60 \cdot (6.895) \cdot \text{MPa} \quad \beta_1 = 0.684$$

$$E_s := 29000 \cdot (6.895) \cdot \text{MPa} \quad E_c := 4730 \cdot \sqrt{\frac{f_c}{1 \cdot \text{MPa}}} \cdot \text{MPa}$$

$$E_{ps} := 28000 \cdot (6.895) \cdot \text{MPa} \quad E_c = 33626 \cdot \text{MPa}$$

$$\epsilon_u := 0.088$$

INITIAL CONDITION

$$V_u := 20 \cdot \text{kN}$$

$$\mu := 1.0$$

$$f_{psi} := .44 \cdot F_{pu}$$

$$f_{psi} = 819.126 \cdot \text{MPa}$$

$$\epsilon_{si} := \frac{f_{psi}}{E_{ps}}$$

$$f_c := \frac{f_{psi} \cdot A_{ps}}{b \cdot h}$$

Check clamping force.

$$\phi := 0.85$$

$$\epsilon_{si} = 0.0035$$

$$f_c = 2.9 \cdot \text{MPa}$$

$$\phi \cdot f_{psi} \cdot A_{ps} > \frac{V_u}{\mu} = 1 \quad \begin{matrix} 0 = n.g. \\ l = ok \end{matrix}$$

Calculate Maximum A_s [Mole, 1994]

$$f_{pe} := f_{psi}$$

Stress in PT steel

$$\theta_{pe} := \frac{1}{d_p} \cdot L_{ups} \cdot \frac{f_{pe}}{E_{ps}}$$

$$\theta_{my} := \frac{1}{d} \cdot (L_u) \cdot \frac{F_y}{E_s}$$

$$\theta_{my} = 2.759 \cdot 10^{-4}$$

$$\theta_{pe} = 0.015$$

$$M_{yld} := 64.90 \cdot 12 \cdot (112.98) \cdot \text{kN} \cdot \text{mm}$$

Experimental yield moment

$$M_{yld} = 8.799 \cdot 10^4 \cdot \text{kN} \cdot \text{mm}$$

$$A_s := \frac{1}{d \cdot F_y} \cdot \frac{\theta_{pe}}{2 \cdot (\theta_{my} + \theta_{pe})} \cdot M_{yld}$$

$$A_s = 274.199 \cdot \text{mm}^2$$

PLASTIC MOMENT CAPACITY

$$\epsilon_s := \epsilon_u \quad f_u := 105 \cdot (6.895) \cdot \text{MPa}$$

$$T_s := A_s \cdot f_u \quad T_s = 199 \cdot \text{kN}$$

$$\Delta_s := \epsilon_s \cdot (L_u + 5.5 \cdot d_b) \quad \Delta_s = 9.08 \cdot \text{mm}$$

assume $c := 4.18 \cdot (25.4) \cdot \text{mm} \quad c = 106.172 \cdot \text{mm}$

$$\Delta_{ps} := \frac{\frac{h}{2} - c}{d - c} \cdot \Delta_s \quad \Delta_{ps} = 3.206 \cdot \text{mm}$$

$$\epsilon_{ps} := \frac{\Delta_{ps}}{L_{ups}} + \epsilon_{si} \quad \epsilon_{ps} = 0.00785$$

$$Q := 0.01992 \quad R := 8.359758 \quad K := 1.04$$

$$f_{ps} := \epsilon_{ps} \cdot E_{ps} \cdot \left[Q + \frac{1 - Q}{\left[1 + \left(\frac{\epsilon_{ps} \cdot E_{ps}}{K \cdot F_{py}} \right)^R \right]^{\frac{1}{R}}} \right]$$

*PT stress-strain curve proposed
by Alan Mattock [Mattock, 1979]*

$$f_{ps} = 1 \cdot 10^3 \cdot \text{MPa}$$

$$\frac{f_{ps}}{F_{pu}} = 79\% \quad \text{must be less than 90\%}$$

$$T_{ps} := A_{ps} \cdot f_{ps}$$

$$T_{ps} = 435 \cdot \text{kN}$$

$$C := T_s + T_{ps}$$

$$C = 633 \cdot \text{kN}$$

$$c := \frac{C}{0.85 \cdot f_c \cdot b \cdot \beta_1}$$

$$c = 106.15 \cdot \text{mm} \quad \text{iterate until "c" converges}$$

$$M_s := T_s \cdot \left(d - \frac{\beta_1 \cdot c}{2} \right)$$

$$M_s = 68 \cdot \text{kN} \cdot \text{m}$$

$$M_{ps} := T_{ps} \cdot \left(\frac{h}{2} - \frac{\beta_1 \cdot c}{2} \right)$$

$$M_{ps} = 73 \cdot \text{kN} \cdot \text{m}$$

$$M_p := M_s + M_{ps}$$

$$M_p = 141.02 \cdot \text{kN} \cdot \text{m}$$

$$\frac{M_s}{M_p} = 0.49$$

JOB NAME: O-P-Z4, Max. A_s

GEOMETRY

$$b := 8 \cdot (25.4) \cdot \text{mm} \quad d_b := 0.375 \cdot (25.4) \cdot \text{mm}$$

$$h := 16 \cdot (25.4) \cdot \text{mm} \quad d := h - 25.4 \cdot \text{mm}$$

$$d_p := \frac{h}{2}$$

$$A_{ps} := 0.459 \cdot (25.4)^2 \cdot \text{mm}^2 \quad L_{ups} := 29 \cdot (25.4) \cdot \text{mm}$$

$$A_{ps} = 296.128 \cdot \text{mm}^2 \quad L_u := 2 \cdot (25.4) \cdot \text{mm}$$

MATERIAL PROPERTIES

$$F_{pu} := 270 \cdot (6.895) \cdot \text{MPa} \quad f_c := 7.66 \cdot (6.895) \cdot \text{MPa}$$

$$F_{py} := 0.9 \cdot F_{pu} \quad \beta_1 := 0.85 - 0.05 \cdot \frac{f_c - 4 \cdot (6.895) \cdot \text{MPa}}{6.895 \cdot \text{MPa}}$$

$$F_y := 60 \cdot (6.895) \cdot \text{MPa} \quad \beta_1 = 0.667$$

$$E_s := 29000 \cdot (6.895) \cdot \text{MPa}$$

$$E_{ps} := 28000 \cdot (6.895) \cdot \text{MPa}$$

$$\epsilon_u := 0.088$$

INITIAL CONDITION

$$V_u := 20 \cdot \text{kN} \quad \mu := 1.0 \quad f_{psi} := .44 \cdot F_{pu} \quad f_{psi} = 819.126 \cdot \text{MPa}$$

$$\epsilon_{si} := \frac{f_{psi}}{E_{ps}} \quad f_c := \frac{f_{psi} \cdot A_{ps}}{b \cdot h}$$

$$\epsilon_{si} = 0.0035 \quad f_c = 2.9 \cdot \text{MPa}$$

Check clamping force.

$$\phi := 0.85$$

$$\phi \cdot f_{psi} \cdot A_{ps} > \frac{V_u}{\mu} = 1 \quad \begin{matrix} 0 = n.g. \\ l = ok \end{matrix}$$

Calculate Maximum A_s [Mole, 1994]

$f_{pe} := f_{psi}$ *Stress in PT steel*

$$\theta_{pe} := \frac{1}{d} \cdot L_{ups} \cdot \frac{f_{pe}}{E_{ps}} \quad \theta_{my} := \frac{1}{d} \cdot (L_u) \cdot \frac{F_y}{E_s}$$

$$\theta_{pe} = 0.015 \quad \theta_{my} = 2.759 \cdot 10^{-4}$$

$M_{yld} := 71.64 \cdot 12 \cdot (112.98) \cdot \text{kN} \cdot \text{mm}$ *Experimental yield moment*

$M_{yld} = 9.713 \cdot 10^4 \cdot \text{kN} \cdot \text{mm}$

$$A_s := \frac{1}{d \cdot F_y} \cdot \frac{\theta_{pe}}{2 \cdot (\theta_{my} + \theta_{pe})} \cdot M_{yld} \quad A_s = 302.676 \cdot \text{mm}^2$$

PLASTIC MOMENT CAPACITY

$$\epsilon_s := \epsilon_u \quad f_u := 105 \cdot (6.895) \cdot \text{MPa}$$

$$T_s := A_s \cdot f_u \quad T_s = 219 \cdot \text{kN}$$

$$\Delta_s := \epsilon_s \cdot (L_u + 5.5 \cdot d_b) \quad \Delta_s = 9.08 \cdot \text{mm}$$

assume $c := 4.223 \cdot (25.4) \cdot \text{mm} \quad c = 107.264 \cdot \text{mm}$

$$\Delta_{ps} := \frac{\frac{h}{2} - c}{d - c} \cdot \Delta_s \quad \Delta_{ps} = 3.182 \cdot \text{mm}$$

$$\epsilon_{ps} := \frac{\Delta_{ps}}{L_{ups}} + \epsilon_{si} \quad \epsilon_{ps} = 0.00782$$

$$Q := 0.01992 \quad R := 8.359758 \quad K := 1.04$$

$$f_{ps} := \epsilon_{ps} \cdot E_{ps} \cdot \left[Q + \frac{1 - Q}{\left[1 + \left(\frac{\epsilon_{ps} \cdot E_{ps}}{K \cdot F_{py}} \right)^R \right]^{\frac{1}{R}}} \right]$$

*PT stress-strain curve proposed
by Alan Mattock [Mattock, 1979]*

$$f_{ps} = 1 \cdot 10^3 \cdot \text{MPa} \quad \frac{f_{ps}}{F_{pu}} = 79.0\% \quad \text{must be less than 90\%}$$

$$T_{ps} := A_{ps} \cdot f_{ps} \quad T_{ps} = 433 \cdot \text{kN}$$

$$C := T_s + T_{ps} \quad C = 653 \cdot \text{kN}$$

$$c := \frac{C}{0.85 \cdot f_c \cdot b \cdot \beta_1} \quad c = 107.26 \cdot \text{mm} \quad \text{iterate until "c" converges}$$

$$M_s := T_s \cdot \left(d - \frac{\beta_1 \cdot c}{2} \right) \quad M_s = 76 \cdot \text{kN} \cdot \text{m}$$

$$M_{ps} := T_{ps} \cdot \left(\frac{h}{2} - \frac{\beta_1 \cdot c}{2} \right) \quad M_{ps} = 73 \cdot \text{kN} \cdot \text{m}$$

$$M_p := M_s + M_{ps} \quad M_p = 148.23 \cdot \text{kN} \cdot \text{m} \quad \frac{M_s}{M_p} = 0.51$$

JOB NAME: P-P-Z4. Max. A_s

GEOMETRY

MATERIAL PROPERTIES

$$\begin{aligned} b &:= 8 \cdot (25.4) \cdot \text{mm} & d_b &:= 0.375 \cdot (25.4) \cdot \text{mm} & F_{pu} &:= 270 \cdot (6.985) \cdot \text{MPa} & f_c &:= 7.76 \cdot (6.895) \cdot \text{MPa} \\ h &:= 16 \cdot (25.4) \cdot \text{mm} & d &:= h - 25.4 \cdot \text{mm} & F_{py} &:= 0.9 \cdot F_{pu} & \beta_1 &:= 0.85 - 0.05 \cdot \frac{f_c - 4 \cdot (6.895) \cdot \text{MPa}}{1 \cdot (6.895) \cdot \text{MPa}} \\ d_p &:= \frac{h}{2} & & & F_y &:= 60 \cdot (6.895) \cdot \text{MPa} & \beta_1 &:= 0.662 \\ A_{ps} &:= 0.459 \cdot (25.4)^2 \cdot \text{mm}^2 & L_{ups} &:= 29 \cdot (25.4) \cdot \text{mm} & E_s &:= 29000 \cdot (6.895) \cdot \text{MPa} \\ A_{ps} &:= 296.128 \cdot \text{mm}^2 & L_u &:= 0 \cdot \text{mm} & E_{ps} &:= 28000 \cdot (6.895) \cdot \text{MPa} \\ & & & & \epsilon_u &:= 0.14 \end{aligned}$$

INITIAL CONDITION

$$\begin{aligned} V_u &:= 20 \cdot \text{kN} & \mu &:= 1.0 & f_{psi} &:= .44 \cdot F_{pu} & f_{psi} &:= 829.818 \cdot \text{MPa} \\ \epsilon_{si} &:= \frac{f_{psi}}{E_{ps}} & f_c &:= \frac{f_{psi} \cdot A_{ps}}{b \cdot h} & & & & \\ \epsilon_{si} &:= 0.0035 & f_c &:= 3.0 \cdot \text{MPa} & & & & \\ & & & & \phi &:= 0.85 & & \\ & & & & \phi \cdot f_{psi} \cdot A_{ps} &> \frac{V_u}{\mu} = 1 & 0 &= n.g. \\ & & & & & & & 1 = ok \end{aligned}$$

Calculate Maximum A_s [Mole, 1994]

$$\begin{aligned} f_{pe} &:= f_{psi} & & \text{Stress in PT steel} \\ \theta_{pe} &:= \frac{1}{d_p} \cdot L_{ups} \cdot \frac{f_{pe}}{E_{ps}} & \theta_{my} &:= \frac{1}{d} \cdot (L_u) \cdot \frac{F_y}{E_s} \\ \theta_{pe} &:= 0.016 & \theta_{my} &:= 0 \end{aligned}$$

$M_{yld} := 69.85 \cdot 12 \cdot (112.98) \cdot \text{kN} \cdot \text{mm}$ *Experimental yield moment*

$$M_{yld} = 9.47 \cdot 10^4 \cdot \text{kN} \cdot \text{mm}$$

$$A_s := \frac{1}{d \cdot F_y} \cdot \frac{\theta_{pe}}{2 \cdot (\theta_{my} + \theta_{pe})} \cdot M_{yld} \quad A_s = 300.406 \cdot \text{mm}^2$$

PLASTIC MOMENT CAPACITY

$$\varepsilon_s := \varepsilon_u \quad f_u := 105 \cdot (6.895) \cdot \text{MPa}$$

$$T_s := A_s \cdot f_u \quad T_s = 217 \cdot \text{kN}$$

$$\Delta_s := \varepsilon_s \cdot (L_u + 5.5 \cdot d_b) \quad \Delta_s = 7.334 \cdot \text{mm}$$

assume $c := 4.182 \cdot (25.4) \cdot \text{mm} \quad c = 106.223 \cdot \text{mm}$

$$\Delta_{ps} := \frac{\frac{h}{2} - c}{d - c} \cdot \Delta_s \quad \Delta_{ps} = 2.588 \cdot \text{mm}$$

$$\varepsilon_{ps} := \frac{\Delta_{ps}}{L_{ups}} + \varepsilon_{si} \quad \varepsilon_{ps} = 0.00701$$

$$Q = 0.01992 \quad R := 8.359758 \quad K := 1.04$$

$$f_{ps} := \varepsilon_{ps} \cdot E_{ps} \cdot \left[Q + \frac{1 - Q}{\left[1 + \left(\frac{\varepsilon_{ps} \cdot E_{ps}}{K \cdot F_{py}} \right)^R \right]^{\frac{1}{R}}} \right]$$

*PT stress-strain curve proposed
by Alan Mattock [Mattock, 1979]*

$$f_{ps} = 1 \cdot 10^3 \cdot \text{MPa}$$

$$\frac{f_{ps}}{F_{pu}} = 71\% \quad \text{must be less than } 90\%$$

$$T_{ps} := A_{ps} \cdot f_{ps}$$

$$T_{ps} = 396 \cdot \text{kN}$$

$$C := T_s + T_{ps}$$

$$C = 614 \cdot \text{kN}$$

$$c := \frac{C}{0.85 \cdot f_c \cdot b \cdot \beta_1}$$

$$c = 100.31 \cdot \text{mm} \quad \text{iterate until "c" converges}$$

$$M_s := T_s \cdot \left(d - \frac{\beta_1 \cdot c}{2} \right)$$

$$M_s = 76 \cdot \text{kN} \cdot \text{m}$$

$$M_{ps} := T_{ps} \cdot \left(\frac{h}{2} - \frac{\beta_1 \cdot c}{2} \right)$$

$$M_{ps} = 67 \cdot \text{kN} \cdot \text{m}$$

$$M_p := M_s + M_{ps}$$

$$M_p = 142.99 \cdot \text{kN} \cdot \text{m}$$

$$\frac{M_s}{M_p} = 0.53$$

CALCULATIONS IN INCH-POUND UNITS

JOB NAME: M-P-Z4. Max. A_s

GEOMETRY

$$b := 8 \cdot \text{in} \quad d_b := 0.375 \cdot \text{in}$$

$$h := 16 \cdot \text{in} \quad d := h - 1 \cdot \text{in}$$

$$d_p := \frac{h}{2}$$

$$A_{ps} := 3 \cdot 153 \cdot \text{in}^2 \quad L_{ups} := 29 \cdot \text{in}$$

$$A_{ps} = 0.459 \cdot \text{in}^2 \quad L_u := 2 \cdot \text{in}$$

MATERIAL PROPERTIES

$$F_{pu} := 270 \cdot \text{ksi} \quad f_c := 7.33 \cdot \text{ksi}$$

$$F_{py} := 0.9 \cdot F_{pu} \quad \beta_1 := 0.85 - 0.05 \cdot \frac{f_c - 4 \cdot \text{ksi}}{1 \cdot \text{ksi}}$$

$$F_y := 60 \cdot \text{ksi} \quad \beta_1 = 0.684$$

$$E_s := 29000 \cdot \text{ksi}$$

$$E_{ps} := 28000 \cdot \text{ksi}$$

$$\epsilon_u := 0.088$$

INITIAL CONDITION

$$V_u := 4.496 \cdot \text{kip} \quad \mu := 1.0$$

$$f_{psi} := 0.44 \cdot F_{pu} \quad f_{psi} = 118.8 \cdot \text{ksi}$$

$$\epsilon_{si} := \frac{f_{psi}}{E_s} \quad f_c := \frac{f_{psi} \cdot A_{ps}}{b \cdot h}$$

Check clamping force.

$$\phi := 0.85$$

$$\epsilon_{si} := 0.0035 \quad f_c = 426 \cdot \text{psi}$$

$$\phi \cdot f_{psi} \cdot A_{ps} > \frac{V_u}{\mu} = 1 \quad \begin{array}{l} 0 = n.g. \\ 1 = ok \end{array}$$

Calculate Maximum A_s [Mole, 1994]

$$f_{pe} := f_{psi} \quad \text{Stress in PT steel}$$

$$\theta_{pe} := \frac{1}{d_p} \cdot L_{ups} \cdot \frac{f_{pe}}{E_{ps}} \quad \theta_{my} := \frac{1}{d} \cdot (L_u) \cdot \frac{F_y}{E_s}$$

$$\theta_{my} = 2.759 \cdot 10^{-4}$$

$$\theta_{pe} = 0.015$$

$$M_{yld} := 64.90 \cdot 12 \cdot \text{kip} \cdot \text{in} \quad \text{Experimental yield moment}$$

$$M_{yld} = 778.8 \cdot \text{kip} \cdot \text{in}$$

$$A_s := \frac{1}{d \cdot F_y} \cdot \frac{\theta_{pe}}{2 \cdot (\theta_{my} + \theta_{pe})} \cdot M_{yld} \quad A_s = 0.425 \cdot \text{in}^2$$

PLASTIC MOMENT CAPACITY

$$\begin{aligned}\epsilon_s &:= \epsilon_u & f_u &:= 105 \cdot \text{ksi} \\ T_s &:= A_s \cdot f_u & T_s &= 45 \cdot \text{kip} \\ \Delta_s &:= \epsilon_s \cdot (L_u + 5.5 \cdot d_b) & \Delta_s &= 0.357 \cdot \text{in}\end{aligned}$$

assume $c := 4.18 \cdot \text{in}$

$$\Delta_{ps} := \frac{\frac{h}{2} - c}{d - c} \cdot \Delta_s \quad \Delta_{ps} = 0.126 \cdot \text{in}$$

$$\epsilon_{ps} := \frac{\Delta_{ps}}{L_{ups}} + \epsilon_{si} \quad \epsilon_{ps} = 0.00785$$

$$Q := 0.01992 \quad R := 8.359758 \quad K := 1.04$$

$$f_{ps} := \epsilon_{ps} \cdot E_{ps} \cdot \left[Q + \frac{1 - Q}{\left[1 + \left(\frac{\epsilon_{ps} \cdot E_{ps}}{K \cdot F_{py}} \right)^R \right]^{\frac{1}{R}}} \right]$$

*PT stress-strain curve proposed
by Alan Mattock [Mattock, 1979]*

$$f_{ps} = 213 \cdot \text{ksi} \quad \frac{f_{ps}}{F_{pu}} = 79\% \quad \text{must be less than } 90\%$$

$$T_{ps} := A_{ps} \cdot f_{ps} \quad T_{ps} = 98 \cdot \text{kip}$$

$$C := T_s + T_{ps} \quad C = 142 \cdot \text{kip}$$

$$c := \frac{C}{0.85 \cdot f_c \cdot b \cdot \beta_1} \quad c = 4.18 \cdot \text{in} \quad \text{iterate until "c" converges}$$

$$M_s := T_s \cdot \left(d - \frac{\beta_1 \cdot c}{2} \right) \quad M_s = 50 \cdot \text{kip} \cdot \text{ft}$$

$$M_{ps} := T_{ps} \cdot \left(\frac{h}{2} - \frac{\beta_1 \cdot c}{2} \right) \quad M_{ps} = 54 \cdot \text{kip} \cdot \text{ft}$$

$$M_p := M_s + M_{ps} \quad M_p = 104.01 \cdot \text{kip} \cdot \text{ft} \quad \frac{M_s}{M_p} = 0.49$$

JOB NAME: O-P-Z4, Max. A_s

GEOMETRY

$$b := 8 \cdot \text{in} \quad d_b := 0.375 \cdot \text{in}$$

$$h := 16 \cdot \text{in} \quad d := h - 1 \cdot \text{in}$$

$$d_p := \frac{h}{2}$$

$$A_{ps} := 3 \cdot 153 \cdot \text{in}^2 \quad L_{ups} := 29 \cdot \text{in}$$

$$A_{ps} = 0.459 \cdot \text{in}^2 \quad L_u := 2 \cdot \text{in}$$

MATERIAL PROPERTIES

$$F_{pu} := 270 \cdot \text{ksi} \quad f_c := 7.66 \cdot \text{ksi}$$

$$F_{py} := 0.9 \cdot F_{pu} \quad \beta_1 := 0.85 - 0.05 \cdot \frac{f_c - 4 \cdot \text{ksi}}{1 \cdot \text{ksi}}$$

$$F_y := 60 \cdot \text{ksi} \quad \beta_1 = 0.667$$

$$E_s := 29000 \cdot \text{ksi}$$

$$E_{ps} := 28000 \cdot \text{ksi}$$

$$\epsilon_u := 0.088$$

INITIAL CONDITION

$$V_u := 4.496 \cdot \text{kip} \quad \mu := 1.0 \quad f_{psi} := .44 \cdot F_{pu} \quad f_{psi} = 118.8 \cdot \text{ksi}$$

$$\epsilon_{si} := \frac{f_{psi}}{E_{ps}} \quad f_c := \frac{f_{psi} \cdot A_{ps}}{b \cdot h}$$

$$\epsilon_{si} = 0.0035 \quad f_c = 0.4 \cdot \text{ksi}$$

Check clamping force.

$$\phi := 0.85$$

$$\phi \cdot f_{psi} \cdot A_{ps} > \frac{V_u}{\mu} = 1 \quad \begin{matrix} 0 = n.g. \\ 1 = ok \end{matrix}$$

Calculate Maximum A_s [Mole, 1994]

$f_{pe} := f_{psi}$ *Stress in PT steel*

$$\theta_{pe} := \frac{1}{d_p} \cdot L_{ups} \cdot \frac{f_{pe}}{E_{ps}} \quad \theta_{my} := \frac{1}{d} \cdot (L_u) \cdot \frac{F_y}{E_s}$$

$$\theta_{pe} = 0.015 \quad \theta_{my} = 2.759 \cdot 10^{-4}$$

$M_{yld} := 71.64 \cdot 12 \cdot \text{kip} \cdot \text{in}$ *Experimental yield moment*

$M_{yld} = 859.68 \cdot \text{kip} \cdot \text{in}$

$$A_s := \frac{1}{d \cdot F_y} \cdot \frac{\theta_{pe}}{2 \cdot (\theta_{my} + \theta_{pe})} \cdot M_{yld} \quad A_s = 0.469 \cdot \text{in}^2$$

PLASTIC MOMENT CAPACITY

$$\epsilon_s := \epsilon_u \quad f_u := 105 \cdot \text{ksi}$$

$$T_s := A_s \cdot f_u \quad T_s = 49 \cdot \text{kip}$$

$$\Delta_s := \epsilon_s \cdot (L_u + 5.5 \cdot d_b) \quad \Delta_s = 0.357 \cdot \text{in}$$

assume $c := 4.223 \cdot \text{in}$

$$\Delta_{ps} := \frac{\frac{h}{2} - c}{d - c} \cdot \Delta_s \quad \Delta_{ps} = 0.125 \cdot \text{in}$$

$$\epsilon_{ps} := \frac{\Delta_{ps}}{L_{ups}} + \epsilon_{si} \quad \epsilon_{ps} = 0.00782$$

$$Q := 0.01992 \quad R := 8.359758 \quad K := 1.04$$

$$f_{ps} := \epsilon_{ps} \cdot E_{ps} \cdot \left[Q + \frac{1 - Q}{\left[1 + \left(\frac{\epsilon_{ps} \cdot E_{ps}}{K \cdot F_{py}} \right)^R \right]^{\frac{1}{R}}} \right] \quad \text{PT stress-strain curve proposed by Alan Mattock [Mattock, 1979]}$$

$$f_{ps} = 212 \cdot \text{ksi} \quad \frac{f_{ps}}{F_{pu}} = 79.0\% \quad \text{must be less than 90\%}$$

$$T_{ps} := A_{ps} \cdot f_{ps} \quad T_{ps} = 97 \cdot \text{kip}$$

$$C := T_s + T_{ps} \quad C = 147 \cdot \text{kip}$$

$$c := \frac{C}{0.85 \cdot f_c \cdot b \cdot \beta_1} \quad c = 4.22 \cdot \text{in} \quad \text{iterate until "c" converges}$$

$$M_s := T_s \cdot \left(d - \frac{\beta_1 \cdot c}{2} \right) \quad M_s = 56 \cdot \text{kip} \cdot \text{ft}$$

$$M_{ps} := T_{ps} \cdot \left(\frac{h}{2} - \frac{\beta_1 \cdot c}{2} \right) \quad M_{ps} = 54 \cdot \text{kip} \cdot \text{ft}$$

$$M_p := M_s + M_{ps} \quad M_p = 109.33 \cdot \text{kip} \cdot \text{ft} \quad \frac{M_s}{M_p} = 0.51$$

JOB NAME: P-P-Z4, Max. A_s

GEOMETRY

$b := 8 \cdot \text{in}$

$h := 16 \cdot \text{in}$

$d_p := \frac{h}{2}$

$A_{ps} := 3 \cdot 153 \cdot \text{in}^2$

$A_{ps} = 0.459 \cdot \text{in}^2$

$d_b := 0.375 \cdot \text{in}$

$d := h - 1 \cdot \text{in}$

$L_{ups} := 29 \cdot \text{in}$

$L_u := 0 \cdot \text{in}$

MATERIAL PROPERTIES

$F_{pu} := 270 \cdot \text{ksi}$

$F_{py} := 0.9 \cdot F_{pu}$

$F_y := 60 \cdot \text{ksi}$

$E_s := 29000 \cdot \text{ksi}$

$E_{ps} := 28000 \cdot \text{ksi}$

$\epsilon_u := 0.14$

$f_c := 7.76 \cdot \text{ksi}$

$\beta_1 := 0.85 - 0.05 \cdot \frac{f_c - 4 \cdot \text{ksi}}{1 \cdot \text{ksi}}$

$\beta_1 = 0.662$

INITIAL CONDITION

$V_u := 4.496 \cdot \text{kip}$

$\epsilon_{si} := \frac{f_{psi}}{E_s}$

$\epsilon_{si} = 0.0035$

$\mu := 1.0$

$f_c := \frac{f_{psi} \cdot A_{ps}}{b \cdot h}$

$f_c = 426 \cdot \text{psi}$

$f_{psi} := .44 \cdot F_{pu}$

$f_{psi} = 118.800 \cdot \text{ksi}$

Check clamping force.

$\phi := 0.85$

$\phi \cdot f_{psi} \cdot A_{ps} > \frac{V_u}{\mu} = 1.000$ $0 = n.g.$
 $1 = ok$

Calculate Maximum A_s [Mole, 1994]

$f_{pe} := f_{psi}$

Stress in PT steel

$\theta_{pe} := \frac{1}{d_p} \cdot L_{ups} \cdot \frac{f_{pe}}{E_{ps}}$

$\theta_{my} := \frac{1}{d} \cdot (L_u) \cdot \frac{F_y}{E_s}$

$\theta_{my} = 0.000$

$\theta_{pe} = 0.015$

$M_{yld} := 69.85 \cdot 12 \cdot \text{kip} \cdot \text{in}$ *Experimental yield moment*

$M_{yld} = 838.200 \cdot \text{kip} \cdot \text{in}$

$A_s := \frac{1}{d \cdot F_y} \cdot \frac{\theta_{pe}}{2 \cdot (\theta_{my} + \theta_{pe})} \cdot M_{yld}$

$A_s = 0.466 \cdot \text{in}^2$

PLASTIC MOMENT CAPACITY

$$\begin{aligned} \epsilon_s &:= \epsilon_u & f_u &:= 105 \cdot \text{ksi} \\ T_s &:= A_s \cdot f_u & T_s &= 49 \cdot \text{kip} \\ \Delta_s &:= \epsilon_s \cdot (L_u + 5.5 \cdot d_b) & \Delta_s &= 0.289 \cdot \text{in} \end{aligned}$$

assume $c := 4.175 \cdot \text{in}$

$$\Delta_{ps} := \frac{\frac{h}{2} - c}{d - c} \cdot \Delta_s \quad \Delta_{ps} = 0.102 \cdot \text{in}$$

$$\epsilon_{ps} := \frac{\Delta_{ps}}{L_{ups}} + \epsilon_{si} \quad \epsilon_{ps} = 0.00702$$

$$Q := 0.01992 \quad R := 8.359758 \quad K := 1.04$$

$$f_{ps} := \epsilon_{ps} \cdot E_{ps} \cdot \left[Q + \frac{1 - Q}{\left[1 + \left(\frac{\epsilon_{ps} \cdot E_{ps}}{K \cdot F_{py}} \right)^R \right]^{\frac{1}{R}}} \right]$$

PT stress-strain curve proposed by Alan Mattock [Mattock, 1979]

$$f_{ps} = 194 \cdot \text{ksi} \quad \frac{f_{ps}}{F_{pu}} = 72\% \quad \text{must be less than } 90\%$$

$$T_{ps} := A_{ps} \cdot f_{ps} \quad T_{ps} = 89 \cdot \text{kip}$$

$$C := T_s + T_{ps} \quad C = 138 \cdot \text{kip}$$

$$c := \frac{C}{0.85 \cdot f_c \cdot b \cdot \beta_1} \quad c = 3.947 \cdot \text{in} \quad \text{iterate until "c" converges}$$

$$M_s := T_s \cdot \left(d - \frac{\beta_1 \cdot c}{2} \right) \quad M_s = 56 \cdot \text{kip} \cdot \text{ft}$$

$$M_{ps} := T_{ps} \cdot \left(\frac{h}{2} - \frac{\beta_1 \cdot c}{2} \right) \quad M_{ps} = 50 \cdot \text{kip} \cdot \text{ft}$$

$$M_p := M_s + M_{ps} \quad M_p = 105.43 \cdot \text{kip} \cdot \text{ft} \quad \frac{M_s}{M_p} = 0.53$$

NIST-114 (REV. 6-93) ADMAN 4.09		U.S. DEPARTMENT OF COMMERCE NATIONAL INSTITUTE OF STANDARDS AND TECHNOLOGY		(ERB USE ONLY)	
MANUSCRIPT REVIEW AND APPROVAL				ERB CONTROL NUMBER	DIVISION
INSTRUCTIONS: ATTACH ORIGINAL OF THIS FORM TO ONE (1) COPY OF MANUSCRIPT AND SEND TO THE SECRETARY, APPROPRIATE EDITORIAL REVIEW BOARD				PUBLICATION REPORT NUMBER	CATEGORY CODE
				PUBLICATION DATE	NUMBER PRINTED PAGES
TITLE AND SUBTITLE (CITE IN FULL)					
Simplified Design Procedure for Hybrid Precast Concrete Connections					
CONTRACT OR GRANT NUMBER 92-OA-055			TYPE OF REPORT AND/OR PERIOD COVERED		
AUTHOR(S) (LAST NAME, FIRST INITIAL, SECOND INITIAL) Cheok, G. S. / Stone, W. C. / Nakaki, S. D.				PERFORMING ORGANIZATION (CHECK (X) ONE BOX)	
				<input checked="" type="checkbox"/>	NIST/GAITHERSBURG
				<input type="checkbox"/>	NIST/BOULDER
				<input type="checkbox"/>	JILA/BOULDER
LABORATORY AND DIVISION NAMES (FIRST NIST AUTHOR ONLY) BFRL, Structures Division					
SPONSORING ORGANIZATION NAME AND COMPLETE ADDRESS (STREET, CITY, STATE, ZIP) Concrete Research Council P.O. Box 19150, 22400 West Seven Mile Road Detroit, MI 48219-0150					
PROPOSED FOR NIST PUBLICATION					
<input type="checkbox"/>	JOURNAL OF RESEARCH (NIST JRES)	<input type="checkbox"/>	MONOGRAPH (NIST MN)	<input type="checkbox"/>	LETTER CIRCULAR
<input type="checkbox"/>	J. PHYS. & CHEM. REF. DATA (JPCRD)	<input type="checkbox"/>	NATL. STD. REF. DATA SERIES (NIST NSRDS)	<input type="checkbox"/>	BUILDING SCIENCE SERIES
<input type="checkbox"/>	HANDBOOK (NIST HB)	<input type="checkbox"/>	FEDERAL INF. PROCESS. STDS. (NIST FIPS)	<input type="checkbox"/>	PRODUCT STANDARDS
<input type="checkbox"/>	SPECIAL PUBLICATION (NIST SP)	<input type="checkbox"/>	LIST OF PUBLICATIONS (NIST LP)	<input type="checkbox"/>	OTHER _____
<input type="checkbox"/>	TECHNICAL NOTE (NIST TN)	<input checked="" type="checkbox"/>	NIST INTERAGENCY/INTERNAL REPORT (NISTIR)		
PROPOSED FOR NON-NIST PUBLICATION (CITE FULLY)			<input type="checkbox"/> U.S.	<input type="checkbox"/> FOREIGN	PUBLISHING MEDIUM
					<input type="checkbox"/> PAPER
					<input type="checkbox"/> DISKETTE (SPECIFY) _____
					<input type="checkbox"/> OTHER (SPECIFY) _____
SUPPLEMENTARY NOTES					
ABSTRACT (A 2000-CHARACTER OR LESS FACTUAL SUMMARY OF MOST SIGNIFICANT INFORMATION. IF DOCUMENT INCLUDES A SIGNIFICANT BIBLIOGRAPHY OR LITERATURE SURVEY, CITE IT HERE. SPELL OUT ACRONYMS ON FIRST REFERENCE.) (CONTINUE ON SEPARATE PAGE, IF NECESSARY.)					
A design procedure is presented to compute the maximum (plastic) moment, the nominal moment, and the story drift capacities of a hybrid precast moment-resisting beam-to-column connection. The hybrid connections consist of mild steel which is used to dissipate energy by yielding and high strength prestressing steel which is used to provide the shear resistance through friction developed at the beam-column interface by the post-tensioning force. The design procedure is based on three 1/3-scale hybrid precast beam-to-column connections tested at the National Institute of Standards and Technology (NIST). The simplified procedure relies on the stress-strain behavior of mild steel up to its ultimate strength and is based on equilibrium equations at the beam-column joint. The appendices include a proposed evaluation criteria for this hybrid connection, sample calculations using the design procedure, and other calculations used to develop the design criteria.					
KEY WORDS (MAXIMUM OF 9; 28 CHARACTERS AND SPACES EACH; SEPARATE WITH SEMICOLONS; ALPHABETIC ORDER; CAPITALIZE ONLY PROPER NAMES)					
Building technology; beam-column; concrete; connection; drift capacity; joint; moment capacity; precast; post-tensioning, seismic design procedure.					
AVAILABILITY				NOTE TO AUTHOR(S): IF YOU DO NOT WISH THIS MANUSCRIPT ANNOUNCED BEFORE PUBLICATION, PLEASE CHECK HERE. <input type="checkbox"/>	
<input type="checkbox"/>	UNLIMITED	<input type="checkbox"/>	FOR OFFICIAL DISTRIBUTION - DO NOT RELEASE TO NTIS		
<input type="checkbox"/>	ORDER FROM SUPERINTENDENT OF DOCUMENTS, U.S. GPO, WASHINGTON, DC 20402				
<input type="checkbox"/>	ORDER FROM NTIS, SPRINGFIELD, VA 22161				
WORDPERFECT					

