

SEISMIC RESPONSE OF
STRUCTURAL SYSTEM WITH RANDOM PARAMETERS

by

Mohsen Ghafory-Ashtiany
and
Mahendra P. Singh

A Technical Report of Research Supported by
The National Science Foundation Under Grant
No. PFR-8023978

Department of Engineering Science and Mechanics
Virginia Polytechnic Institute and State University
Blacksburg, Virginia 24061

September 1981

ACKNOWLEDGEMENTS

This report is based on the Master of Science thesis of Mohsen Ghafory-Ashtiany, submitted in partial fulfillment of the requirements for the degree of Master of Science in Engineering Mechanics at Virginia Polytechnic Institute and State University. This study was partially funded by the National Science Foundation Grant No. PFR-8023978. This support is gratefully acknowledged.

DISCLAIMER

The opinions, findings and conclusions or recommendations expressed in this report are those of the writers and do not necessarily reflect the views of the National Science Foundation.

TABLE OF CONTENTS

	<u>Page</u>
ACKNOWLEDGEMENTS	iii
DISCLAIMER	iv
TABLE OF CONTENTS	v
LIST OF TABLES	vii
LIST OF FIGURES	viii
NOTATION	xi
CHAPTER:	
1. INTRODUCTION	1
1.1 GENERAL REMARKS AND LITERATURE REVIEW	1
1.2 SCOPE OF STUDY	5
1.3 ORGANIZATION	5
2. EQUATIONS OF MOTION OF A STRUCTURAL SYSTEM	7
2.1 INTRODUCTION	7
2.2 EQUATIONS OF MOTION OF A TORSIONAL SYSTEM	8
2.3 DYNAMIC CHARACTERISTICS OF A SINGLE-STORY SYSTEM	14
3. SEISMIC RESPONSE ANALYSIS	18
3.1 INTRODUCTION	18
3.2 STRUCTURAL SYSTEMS WITH PROPORTIONAL DAMPING MATRICES	19
3.2.1 RATES OF CHANGE OF DYNAMIC CHARACTERISTICS FOR PROPORTIONALLY DAMPED CASE	22
3.2.2 RATES OF CHANGE WITH RESPECT TO MASS, STIFFNESS AND ECCENTRICITY VARIABLES	23
3.3 STRUCTURAL SYSTEMS WITH NONPROPORTIONAL DAMPING MATRICES	24
3.3.1 RATES OF CHANGE OF DYNAMIC CHARACTERISTICS FOR NONPROPORTIONALLY DAMPED CASE	25
3.3.2 RATES OF CHANGE WITH RESPECT TO MASS, STIFFNESS AND ECCENTRICITY VARIABLES	30

	<u>Page</u>
CHAPTER:	
3.4 RATE OF CHANGE OF A RESPONSE QUANTITY MODE SHAPE . . .	31
4. NUMERICAL RESULTS	32
4.1 GENERAL	32
4.2 FREQUENCY AND RESPONSE CHARACTERISTICS OF THE SYSTEM .	33
4.2.1 FREQUENCY CHARACTERISTICS	33
4.2.2 CHARACTERISTICS OF RELATIVE DISPLACEMENT AND ROTATION RESPONSES	34
4.2.3 CHARACTERISTICS OF BASE SHEAR AND TORSIONAL MOMENT RESPONSES	34
4.2.4 COLUMN BENDING MOMENT RESPONSE	35
4.3 EFFECT OF VARIATION OF FREQUENCY PARAMETER	37
4.4 COEFFICIENT OF VARIATION OF ROOT MEAN SQUARE RESPONSE	38
5. SUMMARY AND CONCLUSIONS	40
REFERENCES	42
TABLES	45
FIGURES	51
APPENDIX I - MASS, DAMPING AND STIFFNESS MATRICES	83
APPENDIX II	89
II.1 PROPORTIONAL DAMPING CASE	89
II.1.1 FREQUENCY INTEGRALS	89
II.1.2 PARTIAL FRACTION FACTORS, P,Q,R,S	91
II.2 NONPROPORTIONAL DAMPING CASE	92
II.2.1 FREQUENCY INTEGRALS	92
II.2.2 PARTIAL FRACTION FACTORS, P',Q',R',S'	92

LIST OF TABLES

<u>Table</u>	<u>Page</u>
2.1 Torsional Stiffness Ratios for 9 Different Column Layouts in Figs. 2.4	45
4.1 Parameters of Spectral Density Function, $\phi_g(\omega)$, Eq. (4.1)	46
4.2 Coefficient of Variation of Root Mean Square Response of Base Shear for $\beta_x = 0.05$ and $\beta_y = 0.02$	47
4.3 Coefficient of Variation of Root Mean Square Response of Base Torsional Moment for $\beta_x = 0.05$ and $\beta_y = 0.02$	48
4.4 Coefficient of Variation of Root Mean Square Response of y-Bending Moment in Column 1 for $\beta_x = 0.05$ and $\beta_y = 0.02$	49
4.5 Coefficient of Variation of Root Mean Square Response of y-Bending Moment in Column 5 for $\beta_x = 0.05$ and $\beta_y = 0.02$	50

LIST OF FIGURES

<u>Figures</u>	<u>Page</u>
2.1 A Multistory Building with Eccentric Mass and Stiffness Centers	51
2.2 A Typical Plan View of the i th Floor of a Multistory Building	52
2.3 A Single-Story Structural System with Eccentric Mass and Stiffness Centers	53
2.4 Plan View of 9 Different Column Layouts	54
4.1 Lowest Translational and Rotational Frequencies Obtained by Complex and Normal Mode Approach	55
4.2 Rates of Change of Lowest Translational and Rotational Frequencies with Respect to Mass and Stiffness Parameters	56
4.3 Rates of Change of Lowest Translational and Rotational Frequencies with Respect to Eccentricity Parameter	57
4.4 Root Mean Square (RMS) Response of Translational and Rotational ($r\theta$) Displacements Obtained by Complex Mode Approach	58
4.5 RMS Response of Translational and Rotational Displacements Obtained by Complex and Normal Mode Approaches for $\beta_x = 0.05$ and $\beta_y = 0.02$	59
4.6 Rates of Change of RMS Response of Translational and Rotational Displacements with Respect to Mass Parameter	60
4.7 Rates of Change of RMS Response of Translational and Rotational Displacements with Respect to Stiffness Parameter	61
4.8 Rates of Change of RMS Response of Translational and Rotational Displacements with Respect to Eccentricity Parameter	62
4.9 RMS Values of Normalized Base Shear and Torsional Moment Obtained by Complex Mode Approach	63
4.10 RMS Values of Normalized Base Shear and Torsional Moment Obtained by Complex and Normal Mode Approaches for $\beta_x = 0.08$ and $\beta_y = 0.02$	64
4.11 Rates of Change of RMS Values of Normalized Base Shear and Torsional Moment with respect to Mass Parameter	65

	<u>Page</u>
4.12 Rates of Change of RMS Values of Normalized Base Shear and Torsional Moment with Respect to Stiffness Parameter	66
4.13 Rates of Change of RMS Values of Normalized Base Shear and Torsional Moment with Respect to Eccentricity Parameter	67
4.14 RMS Values of Normalized Base Bending Moments in x- and y-directions in Column 1 of Fig. 2.2	68
4.15 RMS Values of Normalized Base Bending Moments in x- and y-directions in Column 5 of Fig. 2.2	69
4.16 RMS Values of Normalized Base Bending Moments in x- and y-directions in Columns 1 and 5 of Fig. 2.2	70
4.17 RMS Values of Normalized Base Bending Moments in x- and y-directions in Column 1 for $\beta_x = 0.08$ and $\beta_y = 0.02$	71
4.18 RMS Values of Normalized Base Bending Moments in x- and y-directions in Column 5 for $\beta_x = 0.08$ and $\beta_y = 0.02$	72
4.19 Rates of Change of RMS Values of Normalized Base Bending Moments in x- and y-directions for Column 1 with Respect to Mass Parameter	73
4.20 Rates of Change of RMS Values of Normalized Base Bending Moments in x- and y-directions for Column 5 with Respect to Mass Parameter	74
4.21 Rates of Change of RMS Values of Normalized Base Bending Moments in x- and y-directions for Column 1 with Respect to Stiffness Parameter	75
4.22 Rates of Change of RMS Values of Normalized Base Bending Moments in x- and y-directions for Column 5 with Respect to Stiffness Parameter	76
4.23 Rates of Change of RMS Values of Normalized Base Bending Moments in x- and y-directions for Column 1 with Respect to Eccentricity Parameter	77
4.24 Rates of Change of RMS Values of Normalized Base Bending Moments in x- and y-directions for Column 5 with Respect to Eccentricity Parameter	78
4.25 RMS Values of Normalized Base Shear for Frequency Parameter Values of 1, 10 and 40 cps	79

	<u>Page</u>
4.26 RMS Values of Normalized Base Torsional Moment for Frequency Parameter Value of 1, 10 and 40 cps	80
4.27 RMS Values of Normalized Base y-Bending Moment in Column 1 for Frequency Parameter Values of 1, 10 and 40 cps	81
4.28 RMS Values of Normalized Base y-Bending Moment in Column 5 for Frequency Parameter Values of 1, 10 and 40 cps	82

NOTATION

The following symbols are used in this report:

- [A] = real symmetric matrix of order $2m$, defined by Eq. (3.18)
- A_j = constant of partial fraction defined by Eq. (II.19)
- $a_{j\ell}$ = constant used in Eqs. (3.9) and (3.24)
- A_{ℓ}^*, B_{ℓ}^* = diagonal elements of diagonal matrices: $[\phi]^T[A][\phi]$ and $[\phi]^T[B][\phi]$ respectively
- a_j, b_j = real and imaginary parts of the j th element of complex eigenvector $\{\phi_j\}$
- [B] = real symmetric matrix of order $2m$, defined by Eq. (3.18)
- [C] = damping matrix
- C_y = damping parameter
- C_{y_i}, C_{θ_i} = total translational and rotational damping value for the i th floor
- C.M. = center of mass
- C.R. = center of resistance or stiffness
- $C_1, C_2, D_1, D_2, E_2, E_3, F$ = constant of partial fraction defined by Eq. (II.18)
- [D] = real symmetric matrix of order $2m$ defined by Eq. (3.18)
- $E[\cdot]$ = expected value
- e = eccentricity parameter
- $e_{x_i} = e_i, e_{y_i}$ = eccentricity in the x - and y -direction at i th floor
- F = Rayleigh's dissipation function
- $[F_j]$ = complex symmetric matrix defined by Eq. (3.20)
- f_j = j th mode shape of a response quantity
- I_i = mass moment of inertia of the i th floor
- $I_1(\omega), I_2(\omega)$ = frequency integral function defined by Eqs. (II.2), (II.5)
- $[K], [\bar{K}]$ = stiffness and mean stiffness matrix

- K_y = stiffness parameter
 K_{x_i}, K_{y_i} = total translational stiffness in the x- and y-direction
 K_{θ_i} = total rotational stiffness in θ -direction
 $k_{x_{ij}}, k_{y_{ij}}$ = x- and y-direction translational stiffness of the jth column in the ith story
 L = the Lagrangian
 L_i = column length or story height
 $[M], [\bar{M}]$ = mass and mean mass matrix
 $M_{x_{ij}}, M_{y_{ij}}$ = bending moment in the x- and y-direction of the jth column at ith story
 m = mass parameter
 m_i = mass of the ith floor
 N = number of stories
 n = number of columns in floor lay-out (Fig. 2.2)
 P, Q, R, S = constants of partial fractions in Eq. (3.1)
 P', Q', R', S' = constants of partial fractions in Eq. (3.16)
 p_j = jth complex eigenvalue
 R_f^2 = mean square value of a response quantity f, defined by Eq. (3.1) for proportional damped case and by Eq. (3.16) for nonproportional one
 r_i = radius of gyration of the ith floor
 r_m, r_k = random mass and stiffness values
 $\{r\}$ = influence coefficient vector
 s, t, u, v = elements of constant matrix [c] defined in Appendix II
 T = Kinetic Energy
 $\{u\}$ = relative displacement vector
 V = Potential Energy
 $\text{Var}[\cdot]$ = variance

W_1, W_2, W_3, W_4	= elements of vector $\{W\}$ defined by Eqs. (II.17)
x_i	= a design variable
\bar{x}_i	= mean value of design variable x_i
Y_j	= relative translational displacement
\ddot{Y}_g	= base acceleration time history
x_{ij}, y_{ij}	= x- and y-coordinate of the jth column measured from center of mass in the ith floor
α_x, α_y	= constant damping coefficient defined in Eq. (2.5)
β	= damping ratio parameter = $C_y/2m\omega$
β_j	= jth modal damping ratio
γ_j	= jth participation factor
ϵ_i	= nondimensional eccentricity ratio = e_i/r
ζ_R, ζ_I	= real and imaginary part of eigenvalue p_j ($p_j = -\zeta_R + i\zeta_I$)
n_i	= translational stiffness ratio = K_{y_i}/K_y
θ_i	= rotational displacement in θ -direction
κ_i	= rotational stiffness ratio = K_{θ_i}/r^2K_y
λ_j	= real eigenvalue
μ_i	= translational damping ratio = C_{y_i}/C_y
ρ_i	= mass ratio = m_i/m
σ_{x_i}	= standard deviation of variable x_i
$\{\phi_j\}$	= jth eigenvector
$\{\phi_j\}_L$	= lower half part of complex eigenvector
ψ_i	= rotational damping ratio = $C_{\theta_i}/r^2C_{y_i}$
ω	= frequency parameter = $\sqrt{K_y/m}$
ω_j	= jth modal frequency
$\frac{\partial}{\partial x}$	= partial derivative with respect to a design parameter x

CHAPTER 1

INTRODUCTION

1.1 General Remarks and Literature Review

Dynamic response of a structural system depends upon its mass, stiffness and damping characteristics. These quantities can rarely be estimated precisely as they depend upon uncertain parameters such as member size, material properties like density and stiffness, and energy dissipation characteristics. Thus these quantities should be considered as random variables in an analytical model of a structure and the calculated dynamic response should reflect and include the uncertainties associated with these parameters.

Often in a dynamic analysis of a structure for earthquake induced ground motions, the effects of the variabilities of these parameters on the design response are included by parametric variation studies in which some extreme values of these parameters are used to obtain a bound on the calculated response. This approach may be adequate but does not combine the uncertainties in a rational and consistent manner. The uncertainties can be combined in a consistent fashion if these parameters are considered as random variables with their variabilities combined probabilistically to ascertain the variability of a response.

Several investigations have been performed in the past in which the effects of changes in these parameters on the dynamic characteristics like frequencies and mode shapes have been obtained. Fox and Kapoor [13] developed a formulation to obtain the rates of change of eigenvalues and eigenvectors with respect to a design parameter. Similar approaches were also used by Collins [9], Collins and Thomson [10],

Hasselmann and Hart [17,18], Hadjian [14], Soong [36], Hart [15] and possibly many others, to ascertain the statistical properties of eigenvalues and eigenvectors for given statistical properties of structural parameters. However, only a limited literature is available on the incorporation of structural parameter uncertainties in the evaluation of structural response. Liu, Child and Nowotny [24] used a Monte Carlo type of approach to incorporate parametric uncertainties in the generation of floor response spectra.

Recently Singh [32] presented a formulation whereby parameter uncertainties are transmitted to structural response through the rates of change of dynamic characteristics. A structural response quantity like bending moment or story shear, etc., can be expressed as a function of dynamic characteristic such as natural frequencies, mode shapes, modal damping, and participation factors and thus its rate of change can be expressed in terms of the rates of change of these dynamic characteristics. This rate of change of response can, in turn, be used in the calculation of variance of response quantity by a first order approximation if the parameter uncertainties are known. Higher order approximations can also be used to improve results if it is desired; however, algebraic manipulations become considerably more involved. In this investigation the first order approximation approach has been used to ascertain the variances of various response quantities for given variances of the mass and stiffness properties of the structure.

For a structure subjected to earthquake induced ground motions, usually a symmetric structural layout is preferred to avoid torsional response (In large size structures the torsional response may still be

induced by travelling seismic waves. See Newmark [26]. This, however, is not the subject of this study). In spite of best efforts to achieve a symmetric layout, however, some inadvertent eccentricity between the mass and stiffness center may still be present because of uncertainty in the distribution of structural mass and stiffness across the structure. In some cases eccentricities could be due to architectural features, or may just be unavoidable. Also the magnitude of such eccentricities will not be precisely known, as these are random variables. It is therefore of interest to study the effect of eccentricity on dynamic response and include its randomness in the evaluation of seismic response.

Structural systems with eccentricity between mass and stiffness centers possess some special characteristics. Especially if the eccentricities are small, the systems will usually have closely spaced (nearly equal) frequencies in certain circumstances. The modes with nearly equal frequencies, often referred to as "closely spaced modes", generally interact strongly. As a result such systems usually require special analysis procedures to calculate their dynamic response accurately. The eccentric structural systems (herein also referred to as torsional systems), therefore, have been of considerable research interest to many investigators. Rosenblueth and Elorduy [28], Amin and Gungor [2], Singh et al [29], Singh and Chu [33], Der Kiureghian [11] have considered systems with closely spaced frequencies and suggested the use of special procedures to obtain accurate responses. Kan and Chopra [21,22,23] have studied eccentric multistory structural systems in detail to suggest some simplified analysis procedures. Tso and Dempsey [37] have also examined a single story two-degree-of-freedom system in order to study the effect of eccentricity on the response and to review various code provisions.

Structural systems made with different materials in different parts would, generally, have nonproportional damping matrices [34]. Other energy dissipation mechanisms could also lead to nonproportional damping matrices in the analytical models. Such matrices cannot be diagonalized by undamped normal modes. That is, if a nonproportional matrix $[C]$ is pre- and post-multiplied by undamped modal matrix $[\phi]$, the resultant matrix, $[\phi]^T[C][\phi]$, will have some off-diagonal terms. These off-diagonal terms represent a modal coupling through damping terms. In eccentric structural systems, where frequencies are closely spaced, and thus the interaction effects are large, these off diagonal terms may attain a special significance. It is suspected that in such systems (with eccentricities), if these off-diagonal damping coupling terms are neglected (that is, if a nonproportional damping matrix is assumed to be a proportional one) the calculated dynamic response may have some significant errors. It is, therefore, of interest here to study eccentric systems with nonproportional damping characteristics.

The analysis of nonproportionally damped systems has also been of considerable interest to many researchers. Bailak [4], Clough and Mojtahedi [6], Hasselman [16], Itoh [20], Johnson and McCaffery [20], Rosset, Whittman and Dobry [28], Singh [30], Warbuton and Soni [38], etc., have studied various aspects of this problem. Several methods of analysis have also been proposed for such systems. In this investigation nonproportional dynamic systems with varying eccentricities have been analyzed by the approach proposed by Singh [30]. For a given nonproportional damping matrix, this approach provides a mathematically accurate response for structures excited by ground motions defined in

stochastic terms or by response spectra curves. For comparison purposes, here the response results have been obtained with and without the assumption of proportionality.

1.2 Scope of Study

In this investigation the effects of uncertainties of mass and stiffness on the response of a structural system have been examined. For given coefficients of variation of mass and stiffness, the coefficient of variation of design response has been obtained. Also structures with and without torsional oscillations have been examined. The effects of varying the eccentricity between the mass and stiffness centers on the dynamic characteristics and response of a multistory building has been examined. Since eccentric systems are expected to be more susceptible to nonproportional damping effects, the responses of such systems with nonproportional damping matrix have been studied in details, and the effect of the commonly made assumption of proportionality for nonproportionally damped systems on the calculation of dynamic response has been evaluated. Only linearly behaving structures have been considered in this investigation.

1.3 Organization

Chapter 2 contains the derivation of the equations of motion for a multistory structural system. The mass, damping and stiffness matrix for such a system are given in Appendix I. In Chapter 3 the procedures for the evaluation of seismic response, and also its rate of change, for proportionally and nonproportionally damped structures for stochastically defined ground motion are presented. Further details of the rates of change of various parameters and frequency integrals are given

in Appendix II. The numerical results for a 5-story torsional building obtained by the procedures described in Chapter 3 are presented in Chapter 4. Summary and conclusions are provided in Chapter 5.

CHAPTER TWO

EQUATIONS OF MOTION OF A STRUCTURAL SYSTEM

2.1 Introduction

For dynamic analysis of structural systems subjected to earthquake induced ground motions, the equations of motion can be written in the following form:

$$[M]\{\ddot{u}\} + [C]\{\dot{u}\} + [K]\{u\} = -[M]\{r\}\ddot{Y}_g(t) \quad (2.1)$$

in which $[M]$, $[C]$, $[K]$, respectively, are the mass, damping and stiffness matrices of the structure; $\{u\}$ is the relative displacement vector; $\ddot{Y}_g(t)$ is the base acceleration time history; $\{r\}$ is the displacement influence coefficient vector [8] and a dot over a vector represents its time derivative.

Here these matrices are defined for various building systems in which masses are assumed to be concentrated at floor levels and the stiffness is provided by elements such as columns or shear walls connecting or supporting various floors. The floor systems are assumed rigid and thus undeformable. In large floors shear deformation may not be entirely insignificant, however, such floor deformations have not been considered here.

In a rigid-floor multistory structure, the floor mass when excited by a horizontal ground motion will, in general, have three degrees of freedom: motion in two horizontal directions plus rotation about the mass center of the floor. However, if the mass and resistance (stiffness) centers are at the same location (that is, zero eccentricity), the rotational component of the motion may be absent if the base excitation

is applied uniformly. This will happen in a symmetrically laid-out building in which the horizontal and rotational motions will be uncoupled and their dynamic behavior can be studied just by separate excitations along the two horizontal directions. Such symmetrical systems represent a special case of more general eccentric systems studied here.

Of special interest here are the systems in which mass and resistance centers do not coincide and are at a distance e , commonly referred to as eccentricity. In such cases the translational motion in two horizontal directions will be coupled with the rotational motion. (Because of the presence of torsional motion here, these systems will often be referred to as torsional systems.) Here the dynamic behavior of such systems has been studied in somewhat greater detail. The effects of variability of eccentricity and its influence on the assumption of proportionality for a nonproportional damping matrix have been studied in detail. In the following section, the development and non-dimensionalization of the equations of motion of a torsional system are presented.

2.2 Equations of Motion of a Torsional System

In general, each floor of a torsional system representing a multi-story building, would have 3 degrees-of-freedom. Each floor could possibly have its own arrangement of connecting elements like columns and shear walls, and this may give rise to different eccentricities for each floor. However, to limit the number of problem parameters in this study, structures with the following special characteristics are

examined:

1. Each floor mass has only two degrees of freedom: translation in one of the two horizontal directions and rotation about a vertical axis. This assumes that the resistance center lies on one of the axes of symmetry passing through the center of mass, and the ground motion is applied in a direction perpendicular to the axis of symmetry. Thus as shown in Fig. 2.1, the eccentricity in the x-direction alone has been considered and the excitation is applied in the y-direction.

2. For analytical ease of parameter manipulation and modeling purposes, but without loss of generality, the stiffness in the system is assumed to have been provided by column elements which connect various floors. The relative locations of the columns with respect to the center of mass determine the torsional rigidity of the system.

Assuming that the coordinate origin is located at the center of mass, the total translational and rotational stiffnesses provided by the resisting elements connecting the (i-1)th and ith floors can be written as [21]:

$$K_{x_i} = \sum_{j=1}^n k_{x_{ij}} \quad (2.2a)$$

$$K_{y_i} = \sum_{j=1}^n k_{y_{ij}} \quad (2.2b)$$

$$K_i = \sum_{j=1}^n k_{x_{ij}} y_{ij}^2 + \sum_{j=1}^n k_{y_{ij}} x_{ij}^2 \quad (2.2c)$$

in which $k_{x_{ij}}$ and $k_{y_{ij}}$, respectively, are the x- and y-direction translational stiffnesses of the jth column in the ith story; x_{ij} and y_{ij} , respectively, are the x- and y-coordinates of the jth column measured

from the center of mass on the i th floor; K_{x_i} and K_{y_i} , respectively, are total translational stiffnesses in the x - and y -directions; K_{θ_i} is the rotational stiffness in the θ -direction; and n is the total number of columns in the i th story.

These total translational stiffnesses can be assumed to be concentrated at the center of resistance. The coordinates of the center of resistance with respect to the mass center define the eccentricities in the system as follows [21]:

$$e_{x_i} = \frac{1}{K_{y_i}} \sum_{j=1}^n k_{y_{ij}} x_{ij} \quad (2.3a)$$

$$e_{y_i} = \frac{1}{K_{x_i}} \sum_{j=1}^n k_{x_{ij}} y_{ij} \quad (2.3b)$$

For the systems considered here, $e_{y_i} = 0$; that is, they are symmetrical about their x -axes. Henceforth the eccentricity e_{x_i} will be denoted by e_i .

3. It is assumed that the centers of mass for all floors lie on a common vertical axis. The centers of resistance for all floors are also assumed to lie on another vertical axis which is at a distance e_i from the axis of the centers of mass.

4. To account for energy dissipation by damping in each deforming element, viscous (relative velocity proportional) dashpots are assumed to exist in parallel with each stiffness element. That is, it is assumed that corresponding to each stiffness element, there is a dashpot. If $c_{x_{ij}}$ and $c_{y_{ij}}$ represent the damping constants corresponding to $k_{x_{ij}}$ and $k_{y_{ij}}$, then total translational and rotational damping constants for the i th story can be written as:

$$c_{x_i} = \sum_{j=1}^n c_{x_{ij}} \quad (2.4a)$$

$$c_{y_i} = \sum_{j=1}^n c_{y_{ij}} \quad (2.4b)$$

$$c_{\theta_i} = \sum_{j=1}^n c_{x_{ij}} y_{ij}^2 + \sum_{j=1}^n c_{y_{ij}} x_{ij}^2 \quad (2.4c)$$

These damping constants will provide a stiffness proportional damping matrix if $c_{x_{ij}}$ and $c_{y_{ij}}$ are assumed directly proportional to $k_{x_{ij}}$ and $k_{y_{ij}}$ with the same constant of proportionality. However, if proportionality constants are not equal, the combined damping matrix will be nonproportional. Here it is assumed that

$$c_{x_{ij}} = \alpha_x k_{x_{ij}}, \quad c_{y_{ij}} = \alpha_y k_{y_{ij}} \quad (2.5)$$

Where, if the proportionality constants α_x and α_y are different, the damping matrix will be nonproportional; otherwise it will be proportional. By adjusting the values of α_x and α_y , different degrees of nonproportionality can be easily achieved.

5. The floor plan for each story is assumed to be the same and is shown in Figure 2.2. The radius of gyration, r , for each floor is also assumed to be the same.

For a structural system described above, the equations of motion can be derived using either Newton's second law, or the method of Virtual Work or Lagrange's equations. Here the Lagrange's equation approach has been used. The Potential and Kinetic energies of the i th floor mass of the system are as follows:

Kinetic Energy, T:

$$T_i = \frac{1}{2} m_i (\dot{Y}_i + \dot{Y}_g)^2 + \frac{1}{2} I_i \dot{\theta}_i^2 \quad i = 1, 2, \dots, N \quad (2.6)$$

where m_i = mass of the i th floor; Y_i = relative translational displacement in the y -direction; θ_i = rotational displacement in the θ -direction; \dot{Y}_g = ground excitation velocity in the y -direction; I_i = mass moment of inertia with respect to the center of mass ($m_i r_i^2$); and N = total number of stories.

Potential Energy, V:

$$\begin{aligned} V_i = & \frac{1}{2} K_{y_i} [(Y_i - Y_{i-1}) + e_i (\theta_i - \theta_{i-1})]^2 \\ & + \frac{1}{2} K_{y_{i+1}} [(Y_{i+1} - Y_i) + e_{i+1} (\theta_{i+1} - \theta_i)]^2 \\ & + \frac{1}{2} K_{\theta_i} (\theta_i - \theta_{i-1})^2 + \frac{1}{2} K_{\theta_{i+1}} (\theta_{i+1} - \theta_i)^2 \\ & i = 1, 2, \dots, N \end{aligned} \quad (2.7)$$

Rayleigh's dissipation function, F,

$$\begin{aligned} F = & \frac{1}{2} C_{y_i} [(\dot{Y}_i - \dot{Y}_{i-1}) + e_i (\dot{\theta}_i - \dot{\theta}_{i-1})]^2 \\ & + \frac{1}{2} C_{y_{i+1}} [(\dot{Y}_{i+1} - \dot{Y}_i) + e_{i+1} (\dot{\theta}_{i+1} - \dot{\theta}_i)]^2 \\ & + \frac{1}{2} C_{\theta_i} (\dot{\theta}_i - \dot{\theta}_{i-1})^2 + \frac{1}{2} C_{\theta_{i+1}} (\dot{\theta}_{i+1} - \dot{\theta}_i)^2 \\ & i = 1, 2, \dots, N \end{aligned} \quad (2.8)$$

In terms of the Lagrangian, L,

$$L = T - V \quad (2.9)$$

the equations of motion can be obtained from the following equation [25]

$$\frac{d}{dt} \left(\frac{\partial L}{\partial \dot{q}_i} \right) - \frac{\partial L}{\partial q_i} + \frac{\partial F}{\partial \dot{q}_i} = 0. \quad (2.10)$$

where q_i 's are generalized displacements which in our notations represent the displacement, Y_i , and rotation, θ_i . Using Eqs. (2.2)-(2.9), the equations of motion for the i th floor in terms of relative displacement Y_i and rotation θ_i can be written as follows:

$$\begin{aligned}
& m_i \ddot{Y}_i + (-C_{y_i}) \dot{Y}_{i-1} + (C_{y_i} + C_{y_{i+1}}) \dot{Y}_i + (-C_{y_{i+1}}) \dot{Y}_{i+1} \\
& + (-K_{y_i}) Y_{i-1} + (K_{y_i} + K_{y_{i+1}}) Y_i + (-K_{y_{i+1}}) Y_{i+1} \\
& + (-e_i C_{y_i}) \dot{\theta}_{i-1} + (e_i C_{y_i} + e_{i+1} C_{y_{i+1}}) \dot{\theta}_i + (-e_{i+1} C_{y_{i+1}}) \dot{\theta}_{i+1} \\
& + (-e_i K_{y_i}) \theta_{i-1} + (e_i K_{y_i} + e_{i+1} K_{y_{i+1}}) \theta_i + (-e_{i+1} K_{y_{i+1}}) \theta_{i+1} \\
& = -m_i \ddot{Y}_g
\end{aligned} \tag{2.11a}$$

$$\begin{aligned}
& m_i r_i^2 \ddot{\theta}_i + (-e_i C_{y_i}) \dot{Y}_{i-1} + (e_i C_{y_i} + e_{i+1} C_{y_{i+1}}) \dot{Y}_i + (-e_{i+1} C_{y_{i+1}}) \dot{Y}_{i+1} \\
& + (-e_i K_{y_i}) Y_{i-1} + (e_i K_{y_i} + e_{i+1} K_{y_{i+1}}) Y_i + (-e_{i+1} K_{y_{i+1}}) Y_{i+1} \\
& + (-C_{\theta_i}) \dot{\theta}_{i-1} + (C_{\theta_i} + C_{\theta_{i+1}}) \dot{\theta}_i + (-C_{\theta_{i+1}}) \dot{\theta}_{i+1} \\
& + (-K_{\theta_i}) \theta_{i-1} + (K_{\theta_i} + K_{\theta_{i+1}}) \theta_i + (-K_{\theta_{i+1}}) \theta_{i+1} = 0.
\end{aligned} \tag{2.11b}$$

To study the effects of various system parameters, it is sometimes convenient to nondimensionalize the equations. For this purpose, a mass parameter "m" (which could be the mass of a floor), a stiffness parameter " K_y " (which could be a story stiffness), a damping parameter " C_y " (which could be the damping of a story), a frequency parameter $\omega = \sqrt{K_y/m}$ and a damping ratio parameter $\beta = C_y/2\omega m$, have been introduced. Also various terms encountered in the equations are expressed in terms of translational stiffness ratios $\eta_i = K_{y_i}/K_y$, rotational stiffness ratio $\kappa_i = K_{\theta_i}/r_i^2 K_{y_i}$, translational damping ratio $\mu_i = C_{y_i}/C_y$, rota-

tional damping ratio $\psi_i = c_{\theta_i} / r^2 c_{y_i}$, and mass ratio $\rho_i = m_i / m$. The eccentricity is expressed in nondimensional terms as $\epsilon_i = e_i / r$.

In terms of these nondimensional parameters, Eqs. (2.11) can be now written in the following form:

$$\begin{aligned} \rho_i \ddot{Y}_i + 2\beta\omega\{-\mu_i \dot{Y}_{i-1} + (\mu_i + \mu_{i+1}) \dot{Y}_i - \mu_{i+1} \dot{Y}_{i+1} + \epsilon_i \mu_i (r\dot{\theta}_{i-1}) \\ + (\epsilon_i \mu_i + \epsilon_{i+1} \mu_{i+1}) (r\dot{\theta}_i) + (-\epsilon_{i+1} \mu_{i+1}) (r\dot{\theta}_{i+1})\} \\ + \omega^2\{-n_i Y_{i-1} + (n_i + n_{i+1}) Y_i - n_{i+1} Y_{i+1} + \epsilon_i n_i (r\theta_{i-1}) \\ + (\epsilon_i n_i + \epsilon_{i+1} n_{i+1}) (r\theta_i) + (-\epsilon_{i+1} n_{i+1}) (r\theta_{i+1})\} = -\rho_i \ddot{Y}_g \quad (2.12a) \end{aligned}$$

$$\begin{aligned} \rho_i \left(\frac{r}{r}\right)^2 (r\ddot{\theta}_i) + 2\beta\omega\{(-\epsilon_i \mu_i) \dot{Y}_{i-1} + (\epsilon_i \mu_i + \epsilon_{i+1} \mu_{i+1}) \dot{Y}_i + (-\epsilon_{i+1} \mu_{i+1}) \dot{Y}_{i+1} \\ + (-\psi_i \mu_i) (r\dot{\theta}_{i-1}) + (\psi_i \mu_i + \psi_{i+1} \mu_{i+1}) (r\dot{\theta}_i) + (-\psi_{i+1} \mu_{i+1}) (r\dot{\theta}_{i+1})\} \\ + \omega^2\{(-\epsilon_i n_i) Y_{i-1} + (\epsilon_i n_i + \epsilon_{i+1} n_{i+1}) Y_i + (-\epsilon_{i+1} n_{i+1}) Y_{i+1} \\ + (-\kappa_i n_i) (r\theta_{i-1}) + (\kappa_i n_i + \kappa_{i+1} n_{i+1}) (r\theta_i) + (-\kappa_{i+1} n_{i+1}) (r\theta_{i+1})\} \\ = 0. \quad (2.12b) \end{aligned}$$

Similar equations are obtained for each floor mass. When combined, these can be written in matrix form as Eq. (2.1), with matrices [M], [C], [K] and vector {u} defined in Appendix I. These matrices can also be written in partitioned form, where each submatrix is analogous to the corresponding matrix for a one story, two-degree-of-freedom torsional structure.

2.3 Dynamic Characteristics of a Single-Story System

It has been pointed out by various investigators [2,27,29] that closeness in frequency is controlled by the eccentricity ratio, ϵ , and

the rotational stiffness parameter, κ . In the following, this has been verified by the study of a single story, two-degree-of-freedom system (see Fig. 2.3) for which the eigenvalues can be obtained in closed form in terms of these parameter values.

For a single-story system, the equation of motion can be written as follows:

$$\begin{bmatrix} 1.0 & 0 \\ 0 & 1.0 \end{bmatrix} \begin{Bmatrix} \ddot{y} \\ \ddot{r}\theta \end{Bmatrix} + 2\beta\omega\mu \begin{bmatrix} 1.0 & \epsilon \\ \epsilon & \psi \end{bmatrix} \begin{Bmatrix} \dot{y} \\ \dot{r}\theta \end{Bmatrix} + \omega^2\eta \begin{bmatrix} 1.0 & \epsilon \\ \epsilon & \kappa \end{bmatrix} \begin{Bmatrix} y \\ r\theta \end{Bmatrix} = - \begin{bmatrix} 1. & 0 \\ 0 & 1. \end{bmatrix} \{r\}\ddot{y}_g \quad (2.13)$$

The eigenvalues for an undamped system can be obtained from the solution of the following characteristic equation:

$$\begin{vmatrix} \omega^2\eta - \lambda & \omega^2\eta\epsilon \\ \omega^2\eta\epsilon & \omega^2\eta\kappa - \lambda \end{vmatrix} = 0. \quad (2.14)$$

which gives two eigenvalues as follows:

$$\lambda = \omega^2\eta \frac{(1+\kappa) \pm \sqrt{(1+\kappa)^2 - 4(\kappa - \epsilon^2)}}{2.0} \quad (2.15)$$

For these two eigenvalues to be equal to each other, the discriminant should be zero. That is,

$$(1+\kappa)^2 - 4\kappa + 4\epsilon^2 = 0. \quad (2.16)$$

or

$$(1-\kappa)^2 = -4\epsilon^2 \quad (2.17)$$

which requires that

$$\epsilon = \frac{e}{r} = 0. \quad (2.18a)$$

and

$$\kappa = \frac{K}{r^2 K_y} = 1.0 \quad (2.18b)$$

Thus, for small values of nondimensional eccentricity, ϵ , and stiffness ratio, κ , close to 1.0, the discriminant will be close to zero and the two frequencies -translational and torsional- of the system will be close to each other. It is in these situations that these modes interact strongly with each other and affect the choice of the methodologies to be used for accurate evaluation of structural response.

Similar behavior has also been observed in multistory buildings. That is, if the eccentricity ratios, ϵ_i , in various floors are small and torsional stiffness ratios, κ_i , are near a value of 1.0, the structural frequencies in translation and torsion will be close to each other. There could possibly be other structural systems where frequencies may also be closely spaced. These are the very same systems in which the simple-to-use method of Square-Root-of-the-Sum-of-the-Squares (SRSS) procedure gives erroneous results [29]. A correct evaluation of response in such systems requires a proper consideration of interaction of modes with close frequencies [27,29,33].

The multi-degree-of-freedom systems examined in this investigation possess these properties. The closeness in the frequencies has been achieved by controlling the eccentricity ratio, ϵ_i , and torsional stiffness ratio, κ_i , as mentioned above. Various column floor plans, as shown in Fig. 2.4, have been examined. The torsional stiffness ratios of these systems are listed in Table 2.1. The floor plans, Figs. 2.4 in which columns are clustered and uniformly distributed around the geometric center, provided torsional stiffness ratio values close to 1.0.

The torsional systems considered here, therefore, are representative of such building floor plan lay-outs, Figs. 2.4.

CHAPTER 3

SEISMIC RESPONSE ANALYSIS

3.1 Introduction

To study the dynamic behavior of structures under earthquake loads here, ground motions have been modeled as stationary random processes which can be characterized by a spectral density function. It is realized that earthquake induced ground motions are essentially nonstationary and thus cannot be characterized by spectral density functions. However, earthquake ground motions have often been modeled by stationary random process by many investigators in the past [2,11,27, 33], as some conclusions of general validity can still be obtained by a study of structures excited by stationary excitations.

In this chapter, seismic response evaluation procedures for structures excited by randomly characterized ground motion are presented. Of special interest here is the evaluation of the sensitivity and variability of response vis-a-vis the changes in various structural parameters. The necessary formulation for systems with proportional and nonproportional damping matrices are presented. As the modal analysis approach is quite often used in seismic analysis and design, especially if one intends to obtain design response from a response spectrum prescribed as seismic design input, the following formulation is also developed with the normal mode approach.

For structural systems excited by randomly characterized ground motion, the design response is directly related to the root mean square response. Usually, the root mean square response is amplified by a factor called the peak factor to obtain the design response. It is,

therefore, of interest here to examine the mean square response. The formulations to obtain the mean square response for proportionally and nonproportionally damped systems using the modal analysis approach have been developed elsewhere. In the following section the expressions used to obtain the mean square response are given. These expressions are then examined with a view to ascertain the variability of the response due to the variabilities of structural parameters.

3.2 Structural Systems with Proportional Damping Matrices

If the damping matrix, $[C]$, in Eq. (2.1) is proportional to either mass or stiffness or a combination of them (see Caughey [6]), then the coupled equations of motion, Eq. (2.1), can be easily decoupled using the undamped normal modes. In terms of these normal modes, the mean square response can be written as [33]:

$$R_f^2 = \sum_{j=1}^m \gamma_j^2 f_j^2 \frac{I_1(\omega_j)}{\omega_j^4} + 2 \sum_{j=1}^m \sum_{k=j+1}^m \gamma_j \gamma_k f_j f_k \left\{ \frac{1}{\omega_j^4} [QI_1(\omega_j) + Pr^2 I_2(\omega_j)] + \frac{1}{\omega_k^4} [SI_1(\omega_k) + RI_2(\omega_k)] \right\} \quad (3.1)$$

in which R_f^2 is the mean square value of a response quantity f , f_j is the j th mode shape of the response quantity, m = the number of degrees of freedom, γ_j is the j th participation factor defined as $\{\phi_j\}^T [M] \{r\} / \{\phi_j\}^T [M] \{\phi_j\}$, $\{\phi_j\}$ is the j th relative displacement mode shape, ω_j is the j th natural frequency, $r = \omega_j / \omega_k$, and $I_1(\omega_j)$ and $I_2(\omega_j)$ are the frequency integrals defined in Appendix II. These integrals depend on the excitation spectral density function, modal frequency, ω_j , and modal damping, β_j . For proportional damping matrix $[C]$, the modal damping ratio is defined as follows:

$$\beta_j = \frac{1}{2\omega_j} \frac{\{\phi_j\}^T [C] \{\phi_j\}}{\{\phi_j\}^T [M] \{\phi_j\}} \quad (3.2)$$

The factors of partial fraction, P, Q, R and S, are also defined in Appendix II.

Eq. (3.1) defines the Square-Root-of-the-Sum-of-the-Squares (SRSS) procedure for calculation of mean square and design response. For structural systems where some frequencies are close to each other, the consideration of the double summation terms in Eq. (3.1) is important to properly include the modal interaction effect to evaluate response accurately [27,33].

The variability of response defined by Eq. (3.1) vis-a-vis the variabilities of mass, stiffness, and eccentricity is now examined. If it is assumed that the design response is a constant times the mean square response, then the variability of the design response can be assessed from the variability of the mean square response. Here, to obtain the variability in the mean square response, which is a function of various basic parameters such as mass, stiffness, eccentricity, etc., a first order perturbation approach is used. Expanding a response quantity, R, which is a function of variables x_1, x_2, \dots, x_n , in terms of Taylor series about the mean value of the variables, and retaining only first order terms, we obtain [3,5]

$$E[R(x_1, x_2, \dots, x_n)] \approx R(\bar{x}_1, \bar{x}_2, \dots, \bar{x}_n) \quad (3.3)$$

$$\text{Var}[R(x_1, x_2, \dots, x_n)] = \sum_{i=1}^n \left(\frac{\partial R}{\partial x_i} \right)^2 \sigma_{x_i}^2 \quad (3.4)$$

in which $E[\cdot]$ denotes the expected value and $\text{Var}[\cdot]$ denotes the var-

iance, $\frac{\partial R}{\partial x_i}$ is the partial derivative with respect to variable x_i obtained at the mean values \bar{x}_i 's and σ_{x_i} 's are the standard deviations of the variables, x_i 's.

This approach requires the evaluation of the rate of change of the response quantity, $\frac{\partial R}{\partial x_i}$. Here R is expressed in terms of dynamic characteristics of the structure, Eq. (3.1), which in turn are functions of basic variables x_i . Thus evaluation of $\frac{\partial R}{\partial x_i}$ will require evaluation of the rates of change of dynamic characteristics such as frequencies, eigenvectors, participation factors, etc., with respect to the basic variable. For example, for Eq. (3.1)

$$\frac{\partial R_f}{\partial x_i} = \frac{1}{2R_f} \frac{\partial (R_f^2)}{\partial x_i} \quad (3.5)$$

and

$$\begin{aligned} \frac{\partial (R_f^2)}{\partial x} = & \sum_{j=1}^m \{ 2\gamma_j f_j \frac{I_1(\omega_j)}{\omega_j} \left(\frac{\partial \gamma_j}{\partial x} f_j + \gamma_j \frac{\partial f_j}{\partial x} \right) + \gamma_j^2 f_j^2 \frac{\partial}{\partial x} \left(\frac{I_1(\omega_j)}{\omega_j} \right) \} \\ & + 2 \sum_{j=1}^m \sum_{k=j+1}^m \left[\left\{ \gamma_j \gamma_k \left(\frac{\partial f_j}{\partial x} f_k + \frac{\partial f_k}{\partial x} f_j \right) + \left(\frac{\partial \gamma_j}{\partial x} \gamma_k + \frac{\partial \gamma_k}{\partial x} \gamma_j \right) f_j f_k \right\} \cdot \right. \\ & \left. \left\{ \frac{1}{4} [QI_1(\omega_j) + Pr^2 I_2(\omega_j)] + \frac{1}{4} [SI_1(\omega_k) + RI_2(\omega_k)] \right\} \right. \\ & + \gamma_j \gamma_k f_j f_k \left\{ \frac{\partial Q}{\partial x} \frac{I_1(\omega_j)}{\omega_j} + Q \frac{\partial}{\partial x} \left[\frac{I_1(\omega_j)}{\omega_j} \right] + Pr^2 \frac{\partial}{\partial x} \left[\frac{I_2(\omega_j)}{\omega_j} \right] \right. \\ & + \left(r^2 \frac{\partial P}{\partial x} + 2Pr \frac{\partial r}{\partial x} \right) \frac{I_2(\omega_j)}{\omega_j} + \frac{\partial S}{\partial x} \frac{I_1(\omega_k)}{\omega_k} \\ & \left. \left. + S \frac{\partial}{\partial x} \left[\frac{I_1(\omega_k)}{\omega_k} \right] + \frac{\partial R}{\partial x} \frac{I_2(\omega_k)}{\omega_k} + R \frac{\partial}{\partial x} \left[\frac{I_2(\omega_k)}{\omega_k} \right] \right\} \right. \end{aligned} \quad (3.6)$$

where the derivatives of frequency integral $\frac{\partial}{\partial x} \left[\frac{I_1(\omega_j)}{4} \right]$, $\frac{\partial}{\partial x} \left[\frac{I_2(\omega_j)}{4} \right]$ and the derivatives of partial fraction factors $\frac{\partial P^j}{\partial x}$, $\frac{\partial Q^j}{\partial x}$, $\frac{\partial R^j}{\partial x}$ and $\frac{\partial S^j}{\partial x}$ are defined in Appendix II.

3.2.1 Rates of Change of Dynamic Characteristics for Proportionally Damped Case

To obtain the rates of change of ω_j , $\{\phi_j\}$, etc., required in equation (3.6), the following equations, which are derived based on the approach presented by Fox and Kapoor [13], have been used:

$$\frac{\partial \lambda_j}{\partial x} = \frac{\{\phi_j\}^T \left(\left[\frac{\partial K}{\partial x} \right] - \lambda_j \left[\frac{\partial M}{\partial x} \right] \right) \{\phi_j\}}{\{\phi_j\}^T [M] \{\phi_j\}}, \quad (3.7)$$

where λ_j is the j th eigenvalue $= \omega_j^2$. The rate of change of ω_j is obtained from:

$$\frac{\partial \omega_j}{\partial x} = \frac{1}{2\omega_j} \frac{\partial \lambda_j}{\partial x} \quad (3.8)$$

To define the rate of change of eigenvectors, the expansion theorem has been used as:

$$\left\{ \frac{\partial \phi_j}{\partial x} \right\} = \sum_{\ell=1}^m a_{j\ell} \{\phi_\ell\}, \quad (3.9)$$

in which $a_{j\ell}$ are defined as:

$$a_{j\ell} = \begin{cases} \frac{1}{\lambda_j - \lambda_\ell} \{\phi_\ell\}^T \left(\left[\frac{\partial K}{\partial x} \right] - \lambda_j \left[\frac{\partial M}{\partial x} \right] - \frac{\partial \lambda_j}{\partial x} [M] \right) \{\phi_j\} & \text{if } j \neq \ell \\ -\frac{1}{2} \{\phi_j\}^T \left[\frac{\partial M}{\partial x} \right] \{\phi_j\} & \text{if } j = \ell \end{cases} \quad (3.10)$$

The rate of change of a participation factor can be expressed in terms of the rates of $\{\phi_j\}$ and $[M]$, and thus the expressions are straightforward. For the modal damping ratio defined by Eq. (3.2), the evaluation of

its rate of change is also straightforward.

3.2.2 Rates of Change with Respect to Mass, Stiffness and Eccentricity Variables.

As mentioned before the design variables of mass, stiffness and eccentricity, e , have been considered in this study. The variability in the mass variable is characterized by a random variable r_m which has a mean value of 1.0 and standard deviation of σ_m as follows:

$$[M] = r_m [\bar{M}] \quad (3.11)$$

where $[M]$ is the random mass matrix with a mean of $[\bar{M}]$. This form of variability assumes that all masses in the structure are perfectly correlated. A similar form is assumed to characterize the variability in stiffness:

$$[K] = r_k [\bar{K}] \quad (3.12)$$

where r_k is also a random variable with mean value of 1.0 and standard deviation σ_k . More complicated characterization of mass and stiffness variabilities (such as different mass and stiffness elements being characterized by different variables) are also possible, but have not been considered here. Various rates of change defined by Eqs. (3.7-3.10) can now be specialized for these basic variables as follows:

Rates of change with respect to r_m : with $[\frac{\partial M}{\partial r_m}] = [\bar{M}]$, $[\frac{\partial K}{\partial r_m}] = 0.$,

$$\frac{\partial \lambda_j}{\partial r_m} = -\lambda_j \quad ; \quad \left\{ \frac{\partial \phi_j}{\partial r_m} \right\} = -\frac{1}{2} \{ \phi_j \} \quad (3.13)$$

$$\frac{\partial \gamma_j}{\partial r_m} = \frac{1}{2} \gamma_j \quad ; \quad \left\{ \frac{\partial \beta_j}{\partial r_m} \right\} = -\frac{1}{2} \beta_j.$$

Rates of change with respect to r_k : with $[\frac{\partial M}{\partial r_k}] = 0.$, $[\frac{\partial K}{\partial r_k}] = [\bar{K}]$,

$$\frac{\partial \lambda_j}{\partial r_k} = \lambda_j \quad ; \quad \left\{ \frac{\partial \phi_j}{\partial r_k} \right\} = 0.$$

(3.14)

$$\frac{\partial \gamma_j}{\partial r_k} = 0. \quad ; \quad \left\{ \frac{\partial \beta_j}{\partial r_k} \right\} = -\frac{1}{2} \beta_j.$$

Rates of change with respect to eccentricity, e: with $\left[\frac{\partial M}{\partial e} \right] = 0.$,

$$\frac{\partial \lambda_j}{\partial e} = \{\phi_j\}^T \left[\frac{\partial K}{\partial e} \right] \{\phi_j\} \quad (3.15a)$$

$$\left\{ \frac{\partial \phi_j}{\partial e} \right\} = \sum_{\substack{\ell=1 \\ \ell \neq j}}^m \frac{1}{\lambda_j - \lambda_\ell} \{\phi_\ell\}^T \left(\left[\frac{\partial K}{\partial e} \right] - \frac{\partial \lambda_j}{\partial e} [M] \right) \{\phi_\ell\} \quad (3.15b)$$

$$\frac{\partial \gamma_j}{\partial e} = \left\{ \frac{\partial \phi_j}{\partial e} \right\}^T [M] (\{r\} - 2\gamma_j \{\phi_j\}) \quad (3.15c)$$

$$\frac{\partial \beta_j}{\partial e} = \frac{1}{2\omega_j} \left(2 \left\{ \frac{\partial \phi_j}{\partial e} \right\}^T [C] \{\phi_j\} + \{\phi_j\}^T \left[\frac{\partial C}{\partial e} \right] \{\phi_j\} \right) - \frac{1}{2} \frac{\partial \omega_j}{\partial e} \beta_j \quad (3.15d)$$

3.3 Structural Systems with Nonproportional Damping Matrices

As discussed in Chapter 2, in this investigation a nonproportional damping matrix is obtained by using values of $\frac{\alpha_x}{\alpha_y}$ other than 1.0. For such a damping matrix, undamped normal modes cannot be used to decouple the equations of motion. However, as shown by Singh [30], it is still possible to obtain the response by an SRSS procedure, similar to Eq. (3.1), if 2m-dimensional complex eigenvalues [25] are used. Herein, this approach has been referred to as 2m-dimensional state vector. A special advantage of this approach is that commonly used response spectra can be used as seismic input for the calculation of design response. The equation defining the mean square response by this approach is as follows [30]:

$$R_f^2 = \sum_{j=1}^m 4[A_j I_1(\omega_j) + a_j^2 I_2(\omega_j)] / \omega_j^2 \quad (3.16)$$

$$\begin{aligned}
& + 2 \sum_{j=1}^m \sum_{k=j+1}^m \{ [Q' I_1(\omega_j)/r^2 + P' I_2(\omega_j)]/\omega_j^2 \\
& \quad + [S' I_1(\omega_k) + R' I_2(\omega_k)]/\omega_k^2 \}
\end{aligned}$$

where A_j , a_j , P' , Q' , R' and S' are defined in Appendix II. The frequency integral $I_1(\omega_j)$ and $I_2(\omega_j)$ are the same as in Eq. (3.1) and are also defined in Appendix II.

To obtain the rate of change of R_f^2 with respect to a design variable, the rates of change of complex eigenvalues and complex eigenvectors (which define A_j , a_j , P' , Q' , R' , S') are required. The procedure to obtain these rates is given in the following section.

3.3.1 Rates of Change of Dynamic Characteristics for Nonproportionally Damped Case:

The equations of motion, Eq. (2.1), for nonproportional damping matrix $[C]$ can be recast in the following form [25]:

$$[A]\{\dot{z}\} + [B]\{z\} = -[D]\left\{\begin{matrix} 0 \\ r \end{matrix}\right\} \ddot{y}_g \quad (3.17)$$

in which the state vector, $\{z\}$, and matrices $[A]$, $[B]$ and $[D]$ are defined as follows:

$$\begin{aligned}
\begin{matrix} \{z\} \\ (2m,1) \end{matrix} &= \begin{matrix} \left\{ \begin{matrix} \dot{u} \\ u \end{matrix} \right\} \\ (2m,1) \end{matrix} ; & \begin{matrix} [A] \\ (2m,2m) \end{matrix} &= \begin{bmatrix} [0.] & [M] \\ [M] & [C] \end{bmatrix} ; \\
\begin{matrix} [B] \\ (2m,2m) \end{matrix} &= \begin{bmatrix} -[M] & [0.] \\ [0.] & [K] \end{bmatrix} ; & \begin{matrix} [D] \\ (2m,2m) \end{matrix} &= \begin{bmatrix} [0.] & [0.] \\ [0.] & [M] \end{bmatrix} \quad (3.18)
\end{aligned}$$

The eigenvalue problem for Eq. (3.17) can be written as:

$$\begin{matrix} [F_j] & \{\phi_j\} & = & \{0\} \\ (2m,2m) & (2m,1) & & (2m,1) \end{matrix} \quad j = 1, 2m \quad (3.19)$$

in which

$$[F_j] = p_j[A] + [B] \quad (3.20)$$

and $\{\phi_j\}$ is the j th $2m$ -dimensional complex eigenvector and p_j is the j th complex eigenvalue. Premultiplying Eq. (3.19) by $\{\phi_j\}^T$ and taking the derivative with respect to a design variable x , we obtain:

$$\left\{ \frac{\partial \phi_j}{\partial x} \right\}^T [F_j] \{\phi_j\} + \{\phi_j\}^T \left[\frac{\partial F_j}{\partial x} \right] \{\phi_j\} + \{\phi_j\}^T [F_j] \left\{ \frac{\partial \phi_j}{\partial x} \right\} = 0. \quad (3.21)$$

Since $[F_j]$ is a symmetric matrix, the first and the last terms are the same and are equal to zero in view of Eq. (3.19). Thus Eq. (3.21)

becomes

$$\{\phi_j\}^T \left[\frac{\partial F_j}{\partial x} \right] \{\phi_j\} = 0. \quad (3.22)$$

Substituting for the derivative of $[F_j]$ in terms of the derivative of $[A]$ and $[B]$, we obtain:

$$\frac{\partial p_j}{\partial x} = - \frac{\{\phi_j\}^T (p_j \left[\frac{\partial A}{\partial x} \right] + \left[\frac{\partial B}{\partial x} \right]) \{\phi_j\}}{\{\phi_j\}^T [A] \{\phi_j\}} \quad (3.23)$$

To obtain the rate of an eigenvector, the expansion theorem is used as:

$$\left\{ \frac{\partial \phi_j}{\partial x} \right\} = \sum_{\ell=1}^{2m} a_{j\ell} \{\phi_\ell\} \quad (3.24)$$

Using Eq. (3.19)

$$[F_j] \left\{ \frac{\partial \phi_j}{\partial x} \right\} = - \left\{ \frac{\partial F_j}{\partial x} \right\} \{\phi_j\}. \quad (3.25)$$

Substituting for $\left\{\frac{\partial \phi_j}{\partial x}\right\}$ from Eq. (3.24)

$$[F_j] \sum_{\ell=1}^{2m} a_{j\ell} \{\phi_\ell\} = -\left[\frac{\partial F_j}{\partial x}\right] \{\phi_j\} \quad (3.26)$$

Premultiplying Eq. (3.26) by $\{\phi_k\}^T$,

$$\sum_{\ell=1}^{2m} a_{j\ell} \{\phi_k\}^T [F_j] \{\phi_\ell\} = -\{\phi_k\}^T \left[\frac{\partial F_j}{\partial x}\right] \{\phi_j\} \quad (3.27)$$

Using orthogonality condition

$$\{\phi_k\}^T [F_j] \{\phi_\ell\} = 0. \quad \text{if } k \neq \ell \quad (3.28)$$

Eq. (3.27) reduces to $a_{j\ell}$ as follows:

$$a_{j\ell} = - \frac{\{\phi_\ell\}^T \left[\frac{\partial F_j}{\partial x}\right] \{\phi_j\}}{\{\phi_\ell\}^T [F_j] \{\phi_\ell\}} \quad (3.29)$$

The numerator of Eq. (3.29) can be written as:

$$\begin{aligned} \{\phi_\ell\}^T \left[\frac{\partial F_j}{\partial x}\right] \{\phi_j\} &= \frac{\partial p_j}{\partial x} \{\phi_\ell\}^T [A] \{\phi_j\} \\ &+ \{\phi_\ell\}^T \left(p_j \left[\frac{\partial A}{\partial x}\right] + \left[\frac{\partial B}{\partial x}\right]\right) \{\phi_j\} \end{aligned} \quad (3.30)$$

The first term on the right hand side of Eq. (3.30) is zero because of the orthogonality condition. The denominator of Eq. (3.29) can also be written in terms of the complex eigenvalues as follows:

$$\{\phi_\ell\}^T [F_j] \{\phi_\ell\} = p_j A_\ell^* + B_\ell^* \quad (3.31)$$

in which

$$A_\ell^* = \{\phi_\ell\}^T [A] \{\phi_\ell\} \text{ and } B_\ell^* = \{\phi_\ell\}^T [B] \{\phi_\ell\} \quad (3.32)$$

If the eigenvectors are normalized with respect to $[A]$, that is $A_\ell^* = 1.0$, then from equation (3.31), $B_\ell^* = -p_j$. Substituting these in

equation (3.31) we obtain:

$$\{\phi_\ell\}^T [F_j] \{\phi_\ell\} = p_j - p_\ell . \quad (3.33)$$

Using Eqs. (3.30) and (3.33), $a_{j\ell}$ is defined as follows:

$$a_{j\ell} = - \frac{1}{p_j - p_\ell} \{\phi_\ell\}^T (p_j \left[\frac{\partial A}{\partial x} \right] + \left[\frac{\partial B}{\partial x} \right]) \{\phi_j\} \quad \text{if } j \neq \ell \quad (3.34)$$

To define $a_{j\ell}$ for $j=\ell$, we use the eigenvector normalization equation as:

$$\{\phi_j\}^T [A] \{\phi_j\} = 1.0 \quad (3.35)$$

Differentiating with respect to x , we obtain:

$$2 \left\{ \frac{\partial \phi_j}{\partial x} \right\}^T [A] \{\phi_j\} + \{\phi_j\}^T \left[\frac{\partial A}{\partial x} \right] \{\phi_j\} = 0. \quad (3.36)$$

Using Eq. (3.24),

$$2 \sum_{\ell=1}^{2m} a_{j\ell} \{\phi_\ell\}^T [A] \{\phi_j\} + \{\phi_j\}^T \left[\frac{\partial A}{\partial x} \right] \{\phi_j\} = 0. \quad (3.37)$$

Using orthogonality and normalization, Eq. (3.35) for eigenvectors, we obtain:

$$a_{jj} = - \frac{1}{2} \{\phi_j\}^T \left[\frac{\partial A}{\partial x} \right] \{\phi_j\} \quad (3.38)$$

With $a_{j\ell}$ defined by Eqs. (3.34) and (3.38), the rate of change of an eigenvector is obtained from Eq. (3.24).

Eqs. (3.23), (3.24), (3.34) and (3.38) giving the rates of change of p_j and complex eigenvectors are defined in terms of matrices and vectors in $2m$ -dimensional space. However, realizing that the upper and lower parts of an eigenvector are simply related as [25],

$$\begin{matrix} \{\phi_j\} \\ (2m,1) \end{matrix} = \begin{matrix} \left\{ \begin{array}{c} p_j \{\phi_j\}_L \\ \hline \{\phi_j\}_L \end{array} \right\} \\ (2m,1) \end{matrix} \quad (3.39)$$

the equation defining the rates can be written in terms of the lower eigenvector $\{\phi_j\}_L$ alone, as follows:

Rate of Eigenvalue:

$$\frac{\partial p_j}{\partial x} = - \{\phi_j\}^T (p_j^2 \left[\frac{\partial M}{\partial x} \right] + p_j \left[\frac{\partial C}{\partial x} \right] + \left[\frac{\partial K}{\partial x} \right]) \{\phi_j\} \quad (3.40)$$

Rate of Eigenvector:

$$\left\{ \frac{\partial \phi_j}{\partial x} \right\} = \sum_{\ell=1}^{2m} a_{j\ell} \{\phi_\ell\} \quad (3.41)$$

where

$$a_{j\ell} = \begin{cases} -\frac{1}{2} \{\phi_j\}^T (2p_j \left[\frac{\partial M}{\partial x} \right] + \left[\frac{\partial C}{\partial x} \right]) \{\phi_j\} & \text{if } j = \ell \\ \frac{1}{(p_\ell - p_j)} \{\phi_\ell\}^T (p_j^2 \left[\frac{\partial M}{\partial x} \right] + p_j \left[\frac{\partial C}{\partial x} \right] + \left[\frac{\partial K}{\partial x} \right]) \{\phi_j\} & \text{if } j \neq \ell \end{cases} \quad (3.42)$$

The $\{\phi_j\}$ in Eqs. (3.40)-(3.42) now represent only the lower part of the j th eigenvector.

The derivatives of quantities such as A_j , a_j , P' , Q' , R' and S' are in turn defined in terms of the rate of p_j and $\{\phi_j\}$ and are given in Appendix II.

In Eq. (3.16), the frequency integrals are defined in terms of the frequency ω_j and modal damping ratio β_j , which in turn are related to the eigenvalue p_j as follows [30]:

$$\omega_j = \sqrt{\zeta_R^2 + \zeta_I^2} \quad (3.43)$$

$$\beta_j = \frac{\zeta_R}{\omega_j} \quad (3.44)$$

where ζ_R and ζ_I are the real and imaginary part of the eigenvalue p_j defined as follows:

$$p_j = -\zeta_R + i\zeta_I \quad (3.45)$$

The rates of change of ω_j and β_j can now be defined in terms of rates of change of real and imaginary parts of p_j , obtained by Eq. (3.23), as follows:

$$\frac{\partial \omega_j}{\partial x} = \frac{1}{\omega_j} \left(\zeta_R \frac{\partial \zeta_R}{\partial x} + \zeta_I \frac{\partial \zeta_I}{\partial x} \right) \quad (3.46)$$

$$\frac{\partial \beta_j}{\partial x} = \frac{1}{\omega_j} \left(\omega_j \frac{\partial \zeta_R}{\partial x} - \zeta_R \frac{\partial \omega_j}{\partial x} \right) \quad (3.47)$$

3.3.2 Rates of Change with Respect to Mass, Stiffness and Eccentricity Variables

The rates of change of p_j and $\{\phi_j\}$ can now be specialized for the basic variables r_m , r_k and e as follows:

Rates of change with respect to r_m :

$$\frac{\partial p_j}{\partial r_m} = - p_j^2 \{\phi_j\}^T [M] \{\phi_j\} \quad (3.48a)$$

$$\begin{aligned} \left\{ \frac{\partial \phi_j}{\partial r_m} \right\} &= - p_j \left(\{\phi_j\}^T [M] \{\phi_j\} \right) \{\phi_j\} \\ &+ \sum_{\substack{\ell=1 \\ \ell \neq j}}^{2m} \frac{1}{(p_\ell - p_j)} p_j^2 \left(\{\phi_\ell\}^T [M] \{\phi_j\} \right) \{\phi_\ell\} \end{aligned} \quad (3.48b)$$

Rates of change with respect to r_k :

$$\frac{\partial p_j}{\partial r_k} = - \{\phi_j\}^T [K] \{\phi_j\} \quad (3.49a)$$

$$\left\{ \frac{\partial \phi_j}{\partial r_m} \right\} = \sum_{\substack{\ell=1 \\ \ell \neq j}}^{2m} \frac{1}{(p_\ell - p_j)} \left(\{\phi_\ell\}^T [K] \{\phi_j\} \right) \{\phi_\ell\} \quad (3.49b)$$

Rates of change with respect to e :

$$\frac{\partial p_j}{\partial e} = - \{\phi_j\}^T \left(p_j \left[\frac{\partial C}{\partial e} \right] + \left[\frac{\partial K}{\partial e} \right] \right) \{\phi_j\} \quad (3.50a)$$

$$\begin{aligned} \left\{ \frac{\partial \phi_j}{\partial e} \right\} &= -\frac{1}{2} \left(\{\phi_j\}^T \left[\frac{\partial C}{\partial e} \right] \{\phi_j\} \right) \{\phi_j\} \\ &+ \sum_{\substack{\ell=1 \\ \ell \neq j}}^{2m} \frac{1}{(p_\ell - p_j)} \{\phi_\ell\}^T (p_j \left[\frac{\partial C}{\partial e} \right] + \left[\frac{\partial K}{\partial e} \right]) \{\phi_j\} \end{aligned} \quad (3.50b)$$

3.4 Rate of Change of a Response Quantity Mode Shape

To assess variability of R_f^2 from Eqs. (3.1) and (3.16), we need the rate of a response quantity mode shape. This response quantity could be story shear, story torsion, bending moment in a column, etc. The mode shapes of these quantities are linearly related to the deformation mode shape $\{\phi_j\}$ as follows:

$$\{f_j\} = [T]\{\phi_j\} \quad (3.51)$$

in which $[T]$ is a transformation matrix, which for force response quantities will involve the stiffness parameter of the system. Using Eq. (3.51), the rate of f_j can be written as:

$$\left\{ \frac{\partial f_j}{\partial x} \right\} = \left[\frac{\partial T}{\partial x} \right] \{\phi_j\} + [T] \left\{ \frac{\partial \phi_j}{\partial x} \right\} \quad (3.52)$$

CHAPTER 4
NUMERICAL RESULTS

4.1 General

In this chapter, various numerical results obtained for a five story, 10-degrees-of-freedom torsional building system shown in Fig. 2.1 are presented. Response values for maximum relative displacement, maximum rotation, base shear, base torsional moment and bending moments in the two corner columns of the first story are obtained. Systems with parameter $\frac{e}{r}$ varying between 0.001 to 0.5 have been considered. (The results for very large $\frac{e}{r}$ (> 3 or more) may not be of much practical interest. However, they are given here for comparison purposes.)

Various combinations of damping ratio values used here are: $\beta = 0.02$, $\alpha_x/\alpha_y = 2.5$; $\beta = 0.02$, $\alpha_x/\alpha_y = 4.0$; $\beta = 0.02$, $\alpha_x/\alpha_y = 1.0$ and $\beta = 0.05$, $\alpha_x/\alpha_y = 0.40$. Numerical results are obtained by the complex mode state vector approach, as well as by the normal mode approach. Comparison of the results obtained by the two approaches shows the sensitivity of the system response to the assumption of proportionality. The frequency parameter, ω , characterizes the stiffness of the system and its values of 1.0, 6.0, 10.0 and 40.0 cycles per second (CPS) have been considered. This parameter governs the lowest frequency of the system. For $\omega = 1.0$ and 40.0 CPS., lowest frequencies of 0.28 and 11.40 CPS, respectively, were obtained. These fundamental frequencies represent a spectrum of structures ranging from a flexible tall multi-story building to a more stiff nuclear power plant.

Also obtained are the rates of change of frequencies, displacement and rotational responses, base story shear and torsional moment and

column bending moments with respect to change in mass, stiffness and eccentricity ratio parameters. These rates show the sensitivity of a response quantity with respect to the variable.

Ground motion used in this study has been modeled by a stationary random process, defined by a spectral density function of the Kanai-Tajimi form [4] as follows:

$$\phi_g(\omega) = \sum_{i=1}^3 S_i \frac{\omega_i^4 + 4\beta_i^2 \omega_i^2 \omega^2}{(\omega_i^2 - \omega^2)^2 + 4\beta_i^2 \omega_i^2 \omega^2} \quad (4.1)$$

The parameters S_i , ω_i and β_i of this density function are given in Table 4.1. This density function represents a fairly broad-band seismic input, suitable for design purposes [33].

4.2 Frequency and Response Characteristics of the System

4.2.1 Frequency Characteristics:

Fig. 4.1 shows the variation with $\frac{e}{r}$ of two lowest frequencies, which can be identified as translational and rotational frequencies. The frequencies were obtained, both by the undamped (normal mode) and damped (complex mode) eigenvalue analyses. However, the difference in the values calculated by the two approaches is indiscernible. Thus the presence of nonproportionality apparently does not affect the values of frequencies. For small values of $\frac{e}{r}$, the two frequencies are close to each other, as has been mentioned by several investigators in the past [2,29]. This indicates a strong coupling between the translational and torsional mode. However, as $\frac{e}{r}$ increases, the separation between these two frequencies increases with decreasing modal interaction effect. The rates of change with respect to mass and stiffness parameters and eccentricity, e , for these two frequencies are shown in Figs. 4.2 and 4.3.

4.2.2 Characteristics of Relative Displacement and Rotation Responses:

Fig. 4.4 shows the variations of the root mean square (RMS) values of the maximum relative displacement (in ft.) and rotational displacement ($r\theta$, in ft. units) of the system: the values for the top floor represent the maximum values. The relative displacement values are first seen to decrease with an increasing value of $\frac{e}{r}$ and then start to increase, whereas, the floor rotation, as would be expected, increases with increasing value of $\frac{e}{r}$.

Fig. 4.5 shows these values obtained by the two approaches: Normal and complex mode approaches. The effect of assuming proportionality, i.e. ignoring the nonproportionality effect introduces some error in the calculation of responses for some low values of $\frac{e}{r}$; however, it does not appear to be very large.

For various sets of damping ratios used, Figs. 4.6-4.8 show the variation with $\frac{e}{r}$ of the rates of change of the relative displacement and rotational responses with respect to the mass and stiffness parameters and eccentricity ratio $\frac{e}{r}$.

4.2.3 Characteristics of Base Shear and Torsional Moment Responses:

The base shear and torsional moment are obtained by a cumulative summation of shear forces and torsional moments obtained in various stories of a multistory system. Such total forces are commonly used in earthquake design of structures, and their values are obtained on the basis of building code specification. Code provisions usually consider inelastic behavior of structures. Here, however, the forces have been obtained only for elastically behaving torsional systems, mainly with the purpose of studying their sensitivity to the change in various structural parameters.

Figs. 4.9 and 4.10 show the variations of normalized base shear and torsional moment RMS values with $\frac{e}{r}$ for various combinations of damping ratios. Normalization is done with respect to the weight parameter mg . Thus, the plotted values in these figures represent the actual values of base shear and torsional moment divided by mg . Again to examine the effects of the assumption of proportionality, both the story shear and torsional moments have been obtained by the normal and complex mode approaches. Again some differences are noticed for small value of $\frac{e}{r}$.

Of special design significance is the rapid build up of torsional moment due to introduction of even small values of $\frac{e}{r} = 0.05$. A corresponding reduction in the story shear is also noted. However, if the presence of eccentricity is in advertant, no advantage of reduction in story shear may be taken in a design. On the other hand, the effect of the increased torsional moment must be considered to ensure safety of a structural design.

Figs. 4.11-4.13 show the rates of change of these design quantities with respect to mass and stiffness parameters and eccentricity ratio $\frac{e}{r}$. Large values of the rates of changes and their variation for small values of $\frac{e}{r}$ may also be noted.

4.2.4 Column Bending Moment Response:

For earthquake design of a structure, one usually obtains the total story shear and torsional moment as per the provisions of an appropriate code. These shear and moment values are then distributed among various columns and other resisting elements to obtain the design bending moments in them. In a dynamic analysis of an elastic system, however, the column bending moment can also be obtained directly by using the bending moment modes in Eq. (3.1). For example, the mode shapes for

bending moment in the j th column of the i th story can be written in terms of the relative displacement and rotation mode shapes as follows:

$$M_{x_{ij}} = \frac{1}{2} k_{x_{ij}} L_i [X_i - X_{i-1} - y_{ij}(\theta_i - \theta_{i-1})] \quad (4.2a)$$

$$M_{y_{ij}} = \frac{1}{2} k_{y_{ij}} L_i [Y_i - Y_{i-1} + x_{ij}(\theta_i - \theta_{i-1})] \quad (4.2b)$$

in which $M_{x_{ij}}$ and $M_{y_{ij}}$ are the bending moments in the x - and y -directions, respectively, are the x - and y -relative displacement and θ_i is the rotation of the i th floor; and x_{ij} and y_{ij} are the coordinates of the column with respect to the mass center.

The variations with $\frac{e}{r}$ of the normalized root mean square bending moment response of columns 1 and 5 of Fig. 2.2 are shown in Figs. 4.14-4.18 for various damping ratio combinations. Again, the normalization is done with respect to the parameter mg . In the calculation of bending moments in these columns, the values of x_{ij} and y_{ij} equal to $\sqrt{1.5} r$ have been used. This will be the case for the corner columns supporting a square floor slab. The lower set of curves is for the bending moment in the x -direction and the higher set is for the bending moment in the y -direction. A difference in the variation trend for columns 1 and 5 is noted. Also plotted on the same scale in Fig. 4.16 are shown the bending moment values in the x - and y -direction for these two columns. The bending moment in column 1 is seen to increase with $\frac{e}{r}$ (almost monotonically, except near the small value of $\frac{e}{r}$), whereas in column 5, it becomes constant with increasing $\frac{e}{r}$. Probably it is due to the reason that for large $\frac{e}{r}$, it is the difference between Y_i and $(\theta_i x_{ij}/r)$ that determines the bending moment in column 5 and as seen from Figs. 4.4 and 4.5 it does not increase rapidly with $\frac{e}{r}$. For column

It is the sum of Y_i and $(\theta_i x_{ij}/r)$ that determines the bending moment and as shown from Fig. 4.16, it is seen to increase more rapidly with $\frac{e}{r}$.

Also shown are the results obtained by the normal and complex mode approaches to evaluate the effect of nonproportionality. It does not seem to introduce much error for column 1, but for column 5 some differences are noted, especially in the y-bending moment values for small values of $\frac{e}{r}$.

Figs. 4.19-4.24 show the variations with $\frac{e}{r}$ of rates of change of the bending moments in column 1 and 5 with respect to mass and stiffness parameters and eccentricity ratio $\frac{e}{r}$ for various sets of damping values. Sensitivity of the bending moment response with respect to eccentricity ratio $\frac{e}{r}$ at small values of $\frac{e}{r}$ is indicated by large change in the rate of change. The differences in the rate of change characteristics of bending moments in the two opposite side columns, column 1 and 5, especially near small values of $\frac{e}{r}$ may also be noted.

4.3 Effect of Variation of Frequency Parameter:

The results shown in Figs. 4.1-4.24 were obtained for a frequency parameter value of 10 cps. which gave a lowest frequency of 2.81 cps. for the system. To examine what effect the bending stiffness will have on various response characteristics, similar plots were also obtained for other values of the frequency parameter. The numerical values of various results were different, but the variation in the values had a similar trend and therefore the results for other values of ω have not been shown. However, for comparison selected results of the response values of base shear, base torsional moment and Y-bending moments in columns 1 and 5 are plotted in Figs. 4.25-4.28 for different values of

the frequency parameter. Higher response values are obtained for a frequency parameter of 10 cps, as the input spectral density function, Eq. 4.1, has a relatively higher ordinates in the frequency range near the corresponding fundamental frequency of 2.81 cps. For the other two frequency parameter values, the spectral density ordinates are of relatively smaller magnitude.

4.4 Coefficient of Variation of Root Mean Square Response

Using Eqs. (3.3) and (3.4), the coefficient of variation of the root mean square response of base shear, base torsional moment and bending moments in columns 1 and 5 due to the variabilities in the mass parameter, stiffness parameter and eccentricity ratio, $\frac{e}{r}$, have been obtained. The coefficients of variation of r_m , r_k and $\frac{e}{r}$ have been taken as 0.15. Columns 2, 3 and 4 in Tables 4.2-4.6 show the coefficients of variation for various responses due to each parameter variation individually, whereas the combined coefficient of variation is shown in column 5. To obtain the combined coefficient of variation, the random variables r_m , r_k and $\frac{e}{r}$ are assumed to be independent. No specific trend in the values is apparent; and even if there were a trend that would be attributable to characteristics of the system. These results, however, demonstrate the application of the methodology proposed herein for the calculation of the uncertainty in the response.

CHAPTER 5

SUMMARY AND CONCLUSIONS

In this study the effects of changes in various structural parameters on the response of a structure excited by random ground excitation has been studied. The random parameters considered are: the structural mass, stiffness and eccentricity between mass and stiffness centers on a floor. The variabilities in the mass and stiffness are characterized by the random variables with the mean values equal to 1.0 and known standard deviations. This assumes that all masses and stiffnesses vary in the same proportion. More involved variations of masses and stiffnesses are also possible. A uniform multistory building with eccentric mass and stiffness center has been studied. The rates of change of frequencies and various response quantities with respect to mass, stiffness and eccentricity parameters are obtained. These rates of change indicate the sensitivity of a quantity with respect to a parameter and emphasize the relative importance of that parameter for that response. These rates are also used in the calculation of response coefficient of variation for given coefficient of variation values of the parameters.

Numerical results are obtained for a five-story, 10-degrees-of-freedom structural system with various damping ratio and frequency parameter values. Both approaches of response calculations- a more accurate complex mode approach and an approximate normal mode approach - have been used to see what error is introduced if the nonproportionality effects of a damping matrix are ignored. Based on these results the following conclusions can be drawn:

1. For large $\frac{e}{r}$ ratios, the system frequencies are rather well separated. In such a case neglecting off-diagonal terms of the matrix $[\Phi]^T[C][\Phi]$, which represent the nonproportional damping coupling are not important and can be neglected. That is, the damping matrix $[C]$ can be assumed to be proportional and the modal damping ratios can be obtained by Eq. 3.2. This may, however, not be done if the $\frac{e}{r}$ ratio is small and the torsional stiffness ratio parameter is close to 1.0. In such a case the structural frequencies are not well separated and modal interaction is possible and it may affect some structural response. However, not very severe effects were observed in some response values even at these low $\frac{e}{r}$ values. Torsional moment response values are in large errors; however, since the torsional moment values are very small at small $\frac{e}{r}$, these large errors are of no practical significance. The differences in the story shear values, Fig. 4.10, and column bending moment values, Fig. 4.18, calculated by the two approaches, may differ significantly for small $\frac{e}{r}$ ratio (less than 0.05). Thus in such a case, if the damping matrix is nonproportional, it may be necessary to use the nonproportional damping analysis approach presented in Ref. [30]. However, at this stage of analysis it appears that for a safe design, the effect of eccentricity may be neglected to obtain a conservative estimate of the total base shear.

2. An introduction of eccentricity in a direction introduces torsional moments in the system. This, however, is seen to reduce the direct story shear. There is a sharp drop in the shear and a fairly sudden rise in torsional moment up to $\frac{e}{r} = 0.05$. However, no advantage in a design can probably be taken of this reduction in a story shear.

For a safe design a value for $\frac{e}{r} = 0$ should be used in the calculations for shear. This conclusion, however, needs further verification by a more complete study in which an eccentricity in the y-direction is also considered. The effects of inadvertent eccentricity inducing torsional moment should, however, be considered, even if a structure is intended to be symmetrical. A consideration of an $\frac{e}{r}$ value of the order of 0.05 for an inadvertent eccentricity seems very desirable.

3. The response coefficient of variation values calculated here reflect the effect of uncertainties in the parameters. No dramatic values of variabilities are obtained. It probably is due to the fact that the seismic input defined by the spectral density function of Eq. (4.1) represents a wide band input. A response spectrum curve for this input is shown to be a broad band spectrum with a flat top over a fairly wide frequency range. The variations in the mass and stiffness, though cause a change in the system frequencies, do not produce much variations in the response. This may, however, not be the case if the input is not broad banded such as the filtered motion of a floor. In such cases, a proper use of the methodology presented here may be desirable to include the variabilities of parameters in the calculation of design response.

References

1. Amin, M. and Ang, A. H.-S., "Nonstationary Stochastic Model of Earthquake Motion", Journal of Engineering Mechanics Division, ASCE, Vol. 94, No. EM2, April 1968.
2. Amin, M. and Gungor, I., "Random Vibration in Seismic Analysis - An Evaluation", Proceedings, ASCE National Meeting on Structural Engineering, Baltimore, MD, April 19-23, 1971.
3. Ang, A. H.-S., Tang, W. H., "Probability Concept in Engineering Planning and Design", J. Wiley and Sons, New York, 1975.
4. Bailak, J., "Modal Analysis for Building - Soil Interaction", Instituto de Ingenieria, Universidad Nacional Autonoma de Mexico, 1975.
5. Benjamin, J. R. and Cornell, C. A., Probability, Statistics, and Decision for Civil Engineers, McGraw Hill Book Co., New York, 1970.
6. Caughey, T. K., "Classical Normal Modes in Damped Linear Dynamic Systems", Journal of Applied Mechanics, Vol. 27, June 1960, pp. 269-271.
7. Clough, R. W. and Mojtahedi, S., "Earthquake Response Analysis Considering Non-Proportional Damping", Journal of Earthquake Engineering and Structural Dynamics, Vol. 4, pp. 489-496 (1976).
8. Clough, R. W. and Penzien, J., Dynamic of Structures, McGraw Hill, 1975.
9. Collins, J. D., "The Eigenvalue Problem for Systems with Statistical Properties", Thesis presented to University of California at Los Angeles, CA, in June 1967, in partial fulfillment of the requirements for the degree of Doctor of Philosophy.
10. Collins, J. D. and Thomson, W. T., "The Eigenvalue Problem for Structural Systems with Statistical Properties", AIAA Journal, American Institute of Aeronautics and Astronautics, Vol. 7, No. 4, April 1969.
11. Der Kiureghian, A., "Structural Response to Stationary Excitation," Journal of the Engineering Mechanics Division, ASCE, Vol. 106, No. EM6, Proc. Paper 15898, Dec. 1980, pp. 1195-1213.
12. Duncan, P. E. and Taylor, R. E., "A Note on the Dynamic Analysis of Non-Proportionally Damped Systems", Journal of Earthquake Engineering and Structural Dynamics, Vol. 7, pp. 99-105 (1979).
13. Fox, R. L. and Kapoor, M. P., "Rates of Change of Eigenvalues and Eigenvectors", AIAA Journal, Vol. 6, No. 12, Dec. 1968, p. 2426.

14. Hadijan, A. H., "Probabilistic Frequency Variation of Concrete Structures", 2nd International Conference on Structural Mechanics in Reactor Technology, Berlin, Sept. 1973.
15. Hart, Gray C., "Eigenvalue Uncertainty in Stressed Structures", Journal of Engineering Mechanic Division, ASCE, Vol. 99, No. EM3, Proc. Paper 9780, June 1973, pp. 481-494.
16. Hasselman, T. K., "Modal Coupling in Lightly Damped Structures", Technical Note, AIAA Journal, Vol. 14, No. 11, Nov. 1976.
17. Hasselman, T. K. and Hart, G. C., "Solution of the Structural Dynamics Eigenproblem by Modal Synthesis: Sensitivity to Coordinate Selection and Parameter Vibration", UCLA Technical Report, UCLA-Eng-7239, June 1972.
18. Hasselman, T. K. and Hart, G. C., "Modal Analysis of Random Structural Systems", Journal of Engineering Mechanic Division, ASCE, Vol. 98, No. EM3, Proc. Paper 8958, June 1972, pp. 561-579.
19. Itoh, Tetsuji, "Damped Vibration Mode Superposition Method for Dynamic Response Analysis", Journal of Earthquake Engineering and Structural Dynamics, Vol. 2, pp. 47-57 (1973).
20. Johnson, T. E. and McCaffery, R. J., "Current Techniques for Analyzing Structures and Equipment for Seismic Effects", presented at the ASCE National Meeting on Water Resources, New Orleans, LA, Feb. 3-7, 1969.
21. Kan, C. L. and Chopra, A. K., "Coupled Lateral Torsional Response of Buildings to Ground Shaking", Report No. EERC 76-13, Earthquake Engineering Research Center, University of California, Berkeley, CA, May 1976.
22. Kan, C. L. and Chopra, A. K., "Effects of Torsional Coupling on Earthquake Forces in Buildings", Journal of the Structural Division, ASCE, Vol. 103, No. ST4, Proc. Paper 12876, April 1977, pp. 805-819.
23. Kan, C. L. and Chopra, A. K., "Elastic Earthquake Analysis of Torsionally Coupled Buildings", International Journal of Earthquake Engineering and Structural Dynamics, Vol. 5, No. 4, October 1977, pp. 395-412.
24. Liu, L. K., Child, C. G. and Nowotny, B., "Effect of Parameter Variations on Floor Response Spectra", ASCE Proceedings, Structural Design of Nuclear Plant Facilities, Vol. II, Chicago, IL, Dec. 17-18, 1973, p. 435.
25. Meirovitch, L., Analytical Methods in Vibration, Macmillan Co., New York, 1967.

26. Newmark, N. M., 1969a, "Torsion in Symmetrical Buildings", Proceedings of the Fourth World Conference on Earthquake Engineering, Santiago, Chile, 2, A-3, 19-32.
27. Rosenblueth, E. and Elorduy, I., "Response of Linear Systems to Certain Transient Disturbance", Proceedings of the Fourth World Conference on Earthquake Engineering, Vol. 1, Santiago, Chile, 1969.
28. Roesset, J. M., Whittman, R. W. and Dobry, R., "Modal Analysis for Structures with Foundation Interaction", Journal of the Structural Division, ASCE, Vol. 99, No. ST3, pp. 399-410, 1973.
29. Singh, A. K., Chu, S. L. and Singh, S., "Influence of Closely Spaced Modes in Response Spectrum Method of Analysis," Proceedings, ASCE Specialty Conference on Structural Design of Nuclear Plant Facilities, Chicago, IL, Dec. 1973.
30. Singh, Mahendra P., "Seismic Response by SRSS for Nonproportional Damping", Journal of the Engineering Mechanics Division, ASCE, Vol. 106, No. EM6, Proc. Paper 15948, Dec. 1980, pp. 1405-1419.
31. Singh, Mahendra P., "Seismic Design Input for Secondary Systems", Journal of the Structural Division, ASCE, Vol. 106, No. ST2, Proc. Paper 15207, Feb. 1980, pp. 505-517.
32. Singh, M. P., "Seismic Response of Structures with Random Parameters", Proceedings of the 7th World Conference on Earthquake Engineering, Istanbul, Turkey, Sept. 8-13, 1980.
33. Singh, M. P. and Chu, S. L., "Stochastic Considerations in Seismic Analysis of Structures", Journal of Earthquake Engineering and Structural Dynamics, Vol. 4, pp. 295-307 (1976).
34. Singh, M. P. and Ghafory-Ashtiany, M., (1980) "Seismic Stability Evaluation of Earth Structure", Report No. VPI-E-80.30, Virginia Polytechnic Institute & State University.
35. Shinozuka, M. and Astill, J., "Random Eigenvalue Problems in Structural Analysis", Paper No. 71-149, American Institute of Astronautics, 9th Aerospace Science Mtg., New York, NY, Jan. 1971.
36. Soong, T. T. "On Perturbation Solution of Linear System Dynamics", Journal of the Society of Industrial and Applied Mathematics, Vol. 13, No. 4, Dec. 1965, pp. 977-987.
37. Tso, W. K. and Dempsey, K. M., "Seismic Torsional Provisions for Dynamic Eccentricity", Journal of Earthquake Engineering and Structural Dynamics, Vol. 8, pp. 275-289 (1980).
38. Warburton, G. B. and Soni, S. R., "Errors in Response Calculations for Non-Classically Damped Structures", Journal of Earthquake Engineering and Structural Dynamics, Vol. 5, pp. 365-376, 1977.

Table 2.1 TORSIONAL STIFFNESS RATIOS FOR 9 DIFFERENT COLUMN LAYOUTS
IN FIGS. 2.4

FLOOR PLAN	Ratio of translational stiffness in x- and y-direc. K_x/K_y					
	0.50	0.75	1.00	1.25	1.50	1.75
a	2.25	2.62	3.00	3.38	3.75	4.13
b	1.65	1.73	1.80	1.88	1.95	2.03
c	1.40	1.43	1.46	1.49	1.51	1.55
d	1.29	1.31	1.32	1.34	1.35	1.37
e	1.65	1.73	1.80	1.88	1.95	2.03
f	1.75	2.13	2.50	2.88	3.25	3.63
g	1.50	1.65	1.80	1.95	2.10	2.25
h	0.97	1.19	1.42	1.65	1.88	2.10
i	1.02	1.22	1.44	1.64	1.84	2.04

Table 4.1 PARAMETERS OF SPECTRAL DENSITY FUNCTION, $\phi_g(\omega)$, Eq. (4.1)

i	S_i ft ² -sec/rad	ω_i rad/sec.	β_i
1	0.0015	13.5	0.3925
2	0.000495	23.5	0.3600
3	0.000375	39.0	0.3350

Table 4.2 Coefficient of Variation of Root Mean Square Response of Base Shear for $\beta_x = 0.05$ and $\beta_y = 0.02$

Eccentricity Ratio ϵ (1)	Coefficient of Variation in Percent Due To			
	Mass Parameter (2)	Stiffness Parameter (3)	Eccentricity Ratio (4)	Combined
0.001	4.272	3.167	0.031	5.318
0.01	3.510	2.411	2.083	4.740
0.02	2.971	1.855	3.509	4.970
0.03	3.067	1.997	3.210	4.868
0.04	3.304	2.250	2.528	4.730
0.05	3.512	2.473	1.932	4.710
0.06	3.667	2.641	1.481	4.755
0.07	3.778	2.766	1.149	4.821
0.08	3.857	2.860	0.901	4.886
0.10	3.954	2.991	0.564	4.990
0.15	4.017	3.186	0.133	5.128
0.20	3.942	3.366	0.092	5.184
0.25	3.744	3.622	0.209	5.214
0.30	3.399	4.008	0.175	5.258
0.40	2.293	5.170	0.827	5.716
0.45	1.762	5.718	1.932	6.287
0.50	1.563	5.922	3.142	6.883

Table 4.3 Coefficient of Variation of Root Mean Square Response of Base Torsional Moment for $\beta_x = 0.05$ and $\beta_y = 0.02$

Eccentricity Ratio ϵ (1)	Coefficient of Variation in Percent Due To			
	Mass Parameter (2)	Stiffness Parameter (3)	Eccentricity Ratio (4)	Combined
0.001	9.822	8.687	14.949	19.885
0.01	8.436	7.299	11.186	15.798
0.02	6.657	5.513	6.349	10.724
0.03	5.683	4.529	3.694	8.152
0.04	5.187	4.022	2.336	6.967
0.05	4.917	3.740	1.592	6.380
0.06	4.759	3.570	1.152	6.060
0.07	4.662	3.459	0.875	5.870
0.08	4.599	3.381	0.692	5.750
0.10	4.529	3.282	0.478	5.613
0.15	4.467	3.172	0.297	5.487
0.20	4.406	3.174	0.266	5.436
0.25	4.237	3.317	0.226	5.386
0.30	3.863	3.677	0.027	5.334
0.40	2.251	5.268	1.907	6.038
0.45	1.206	6.298	4.343	7.744
0.50	0.463	7.020	7.862	10.550

Table 4.4 Coefficient of Variation of Root Mean Square Response of y-Bending Moment in Column 1 for $\beta_x = 0.05$ and $\beta_y = 0.02$

Eccentricity Ratio ε (1)	Coefficient of Variation in Percent Due To			
	Mass Parameter (2)	Stiffness Parameter (3)	Eccentricity Ratio (4)	Combined (5)
0.001	4.630	11.772	0.264	12.653
0.01	5.268	11.174	0.777	12.378
0.02	4.980	11.550	0.173	12.579
0.03	4.789	11.849	0.537	12.791
0.04	4.730	12.020	0.501	12.928
0.05	4.732	12.131	0.315	13.025
0.06	4.761	12.213	0.077	13.109
0.07	4.802	12.282	0.180	13.189
0.08	4.848	12.342	0.445	13.269
0.10	4.944	12.450	0.985	13.431
0.15	5.139	12.642	2.431	13.861
0.20	5.181	12.671	4.101	14.290
0.25	4.948	12.421	6.039	14.671
0.30	4.297	11.573	8.187	14.954
0.40	1.359	8.789	12.273	15.157
0.45	0.680	6.752	13.801	15.380
0.50	2.429	5.020	15.556	16.525

Table 4.5 Coefficient of Variation of Root Mean Square Response of y-Bending Moment in Column 5 for $\beta_x = 0.05$ and $\beta_y = 0.02$

Eccentricity Ratio ϵ (1)	Coefficient of Variation in Percent Due to			
	Mass Parameter (2)	Stiffness Parameter (3)	Eccentricity Ratio (4)	Combined (5)
0.001	4.244	12.152	0.289	12.875
0.01	2.852	13.485	1.713	13.890
0.02	3.201	12.979	0.055	13.368
0.03	3.868	12.334	0.844	12.901
0.04	3.895	11.990	0.949	12.643
0.05	3.966	11.802	0.802	12.476
0.06	3.980	11.684	0.601	12.357
0.07	3.967	11.599	0.403	12.265
0.08	3.943	11.532	0.223	12.190
0.10	3.882	11.423	0.075	12.069
0.15	3.733	11.246	0.538	11.862
0.20	3.626	11.133	0.706	11.730
0.25	3.558	11.064	0.607	11.638
0.30	3.496	11.004	0.192	11.548
0.40	3.089	10.602	1.720	11.176
0.45	2.501	10.028	3.354	10.866
0.50	1.705	9.242	5.464	10.871

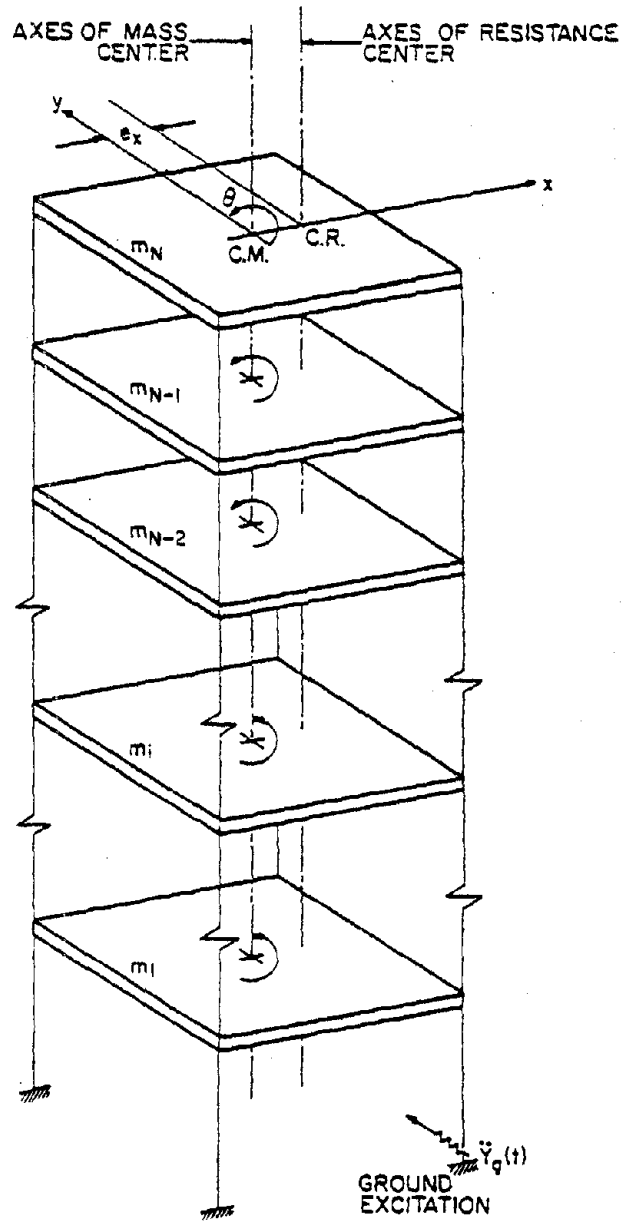

FIG. 2.1 A MULTISTORY BUILDING WITH ECCENTRIC MASS AND STIFFNESS CENTERS

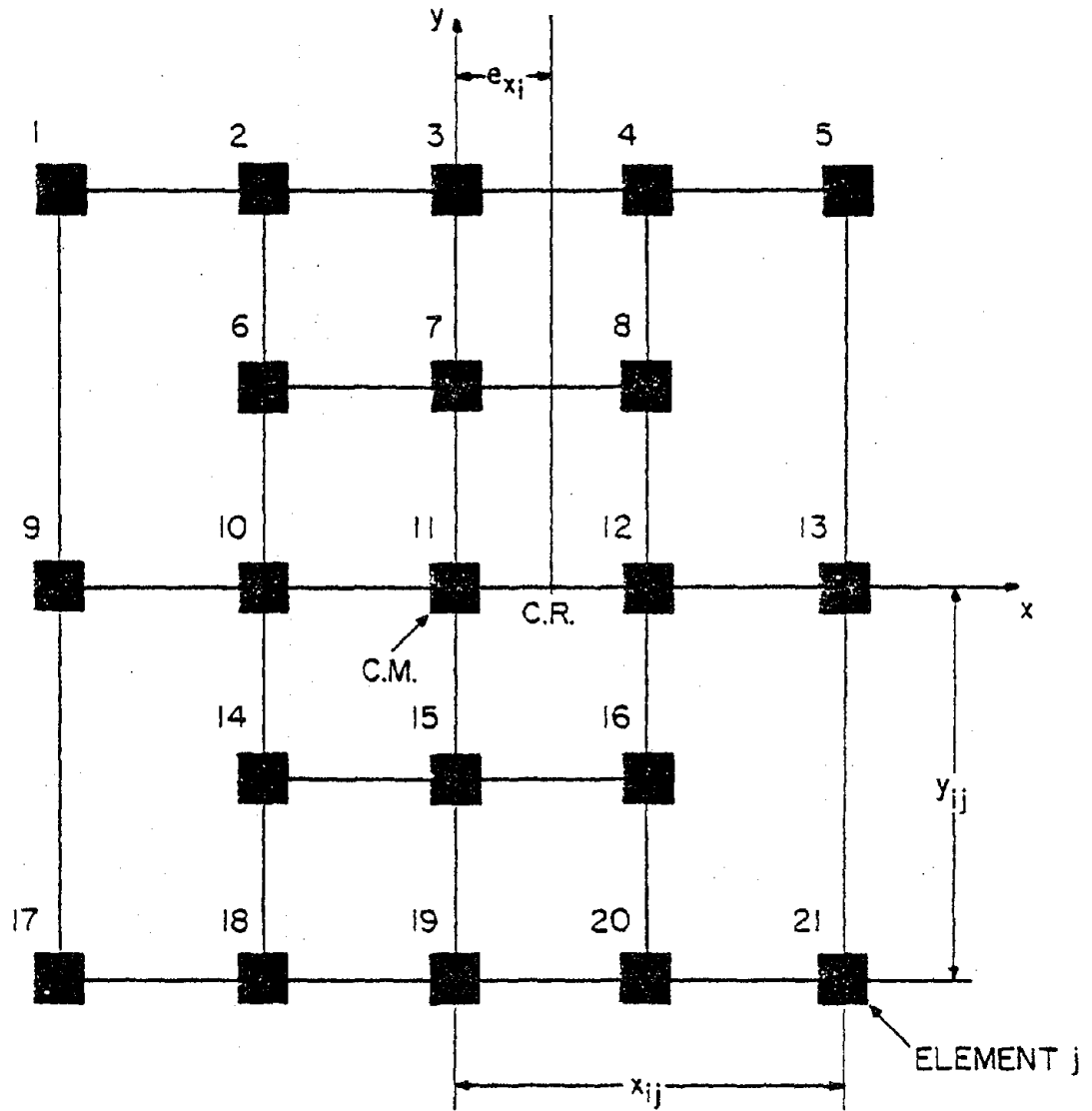

FIG. 2.2 A TYPICAL PLAN VIEW OF THE i th FLOOR OF A MULTISTORY BUILDING

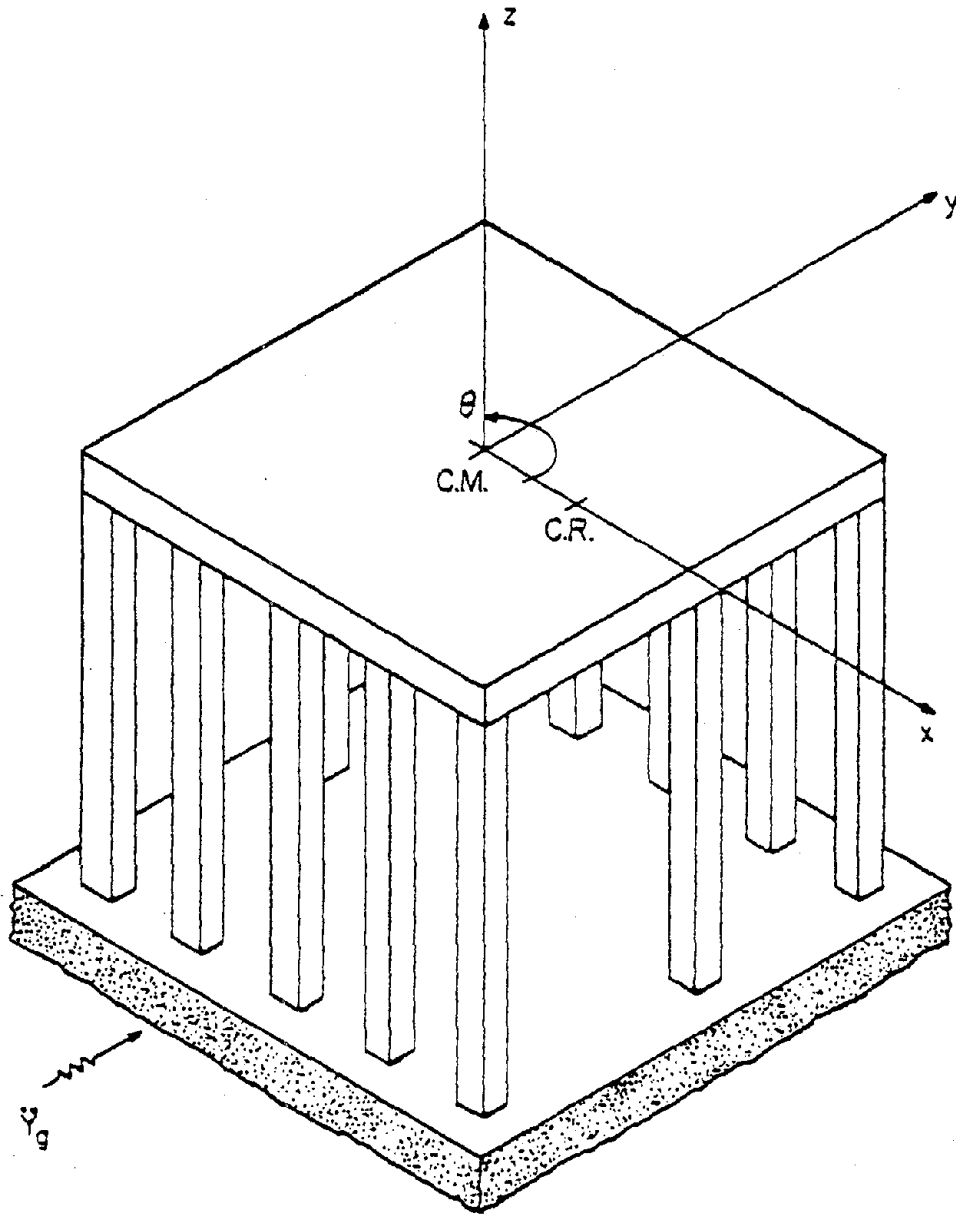

FIG. 2.3 A SINGLE STORY STRUCTURAL SYSTEM WITH ECCENTRIC MASS AND STIFFNESS CENTERS

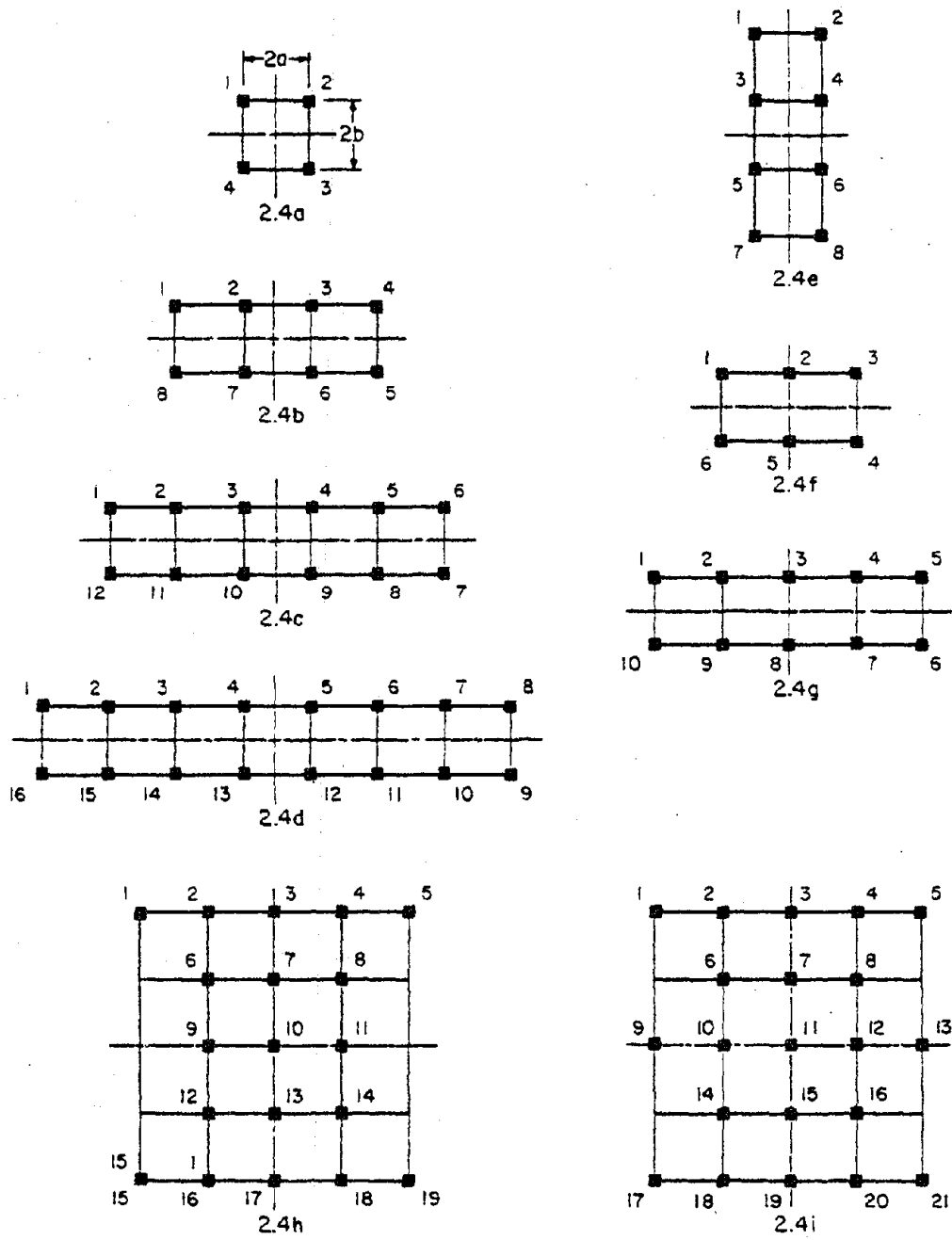

FIG. 2.4 PLAN VIEW OF 9 DIFFERENT COLUMN LAYOUTS.

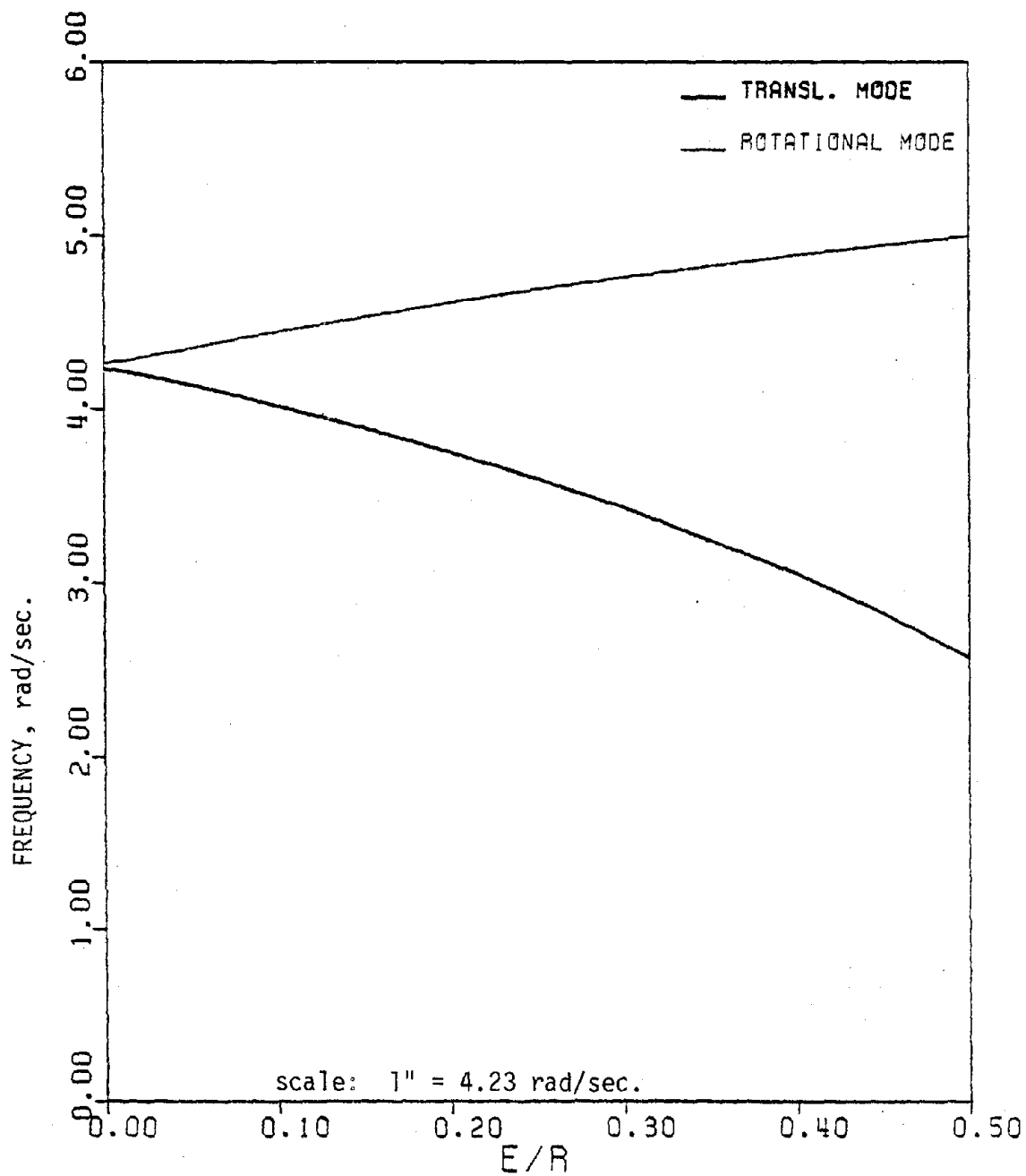

FIG. 4.1 LOWEST TRANSLATIONAL AND ROTATIONAL FREQUENCIES OBTAINED BY COMPLEX AND NORMAL MODE

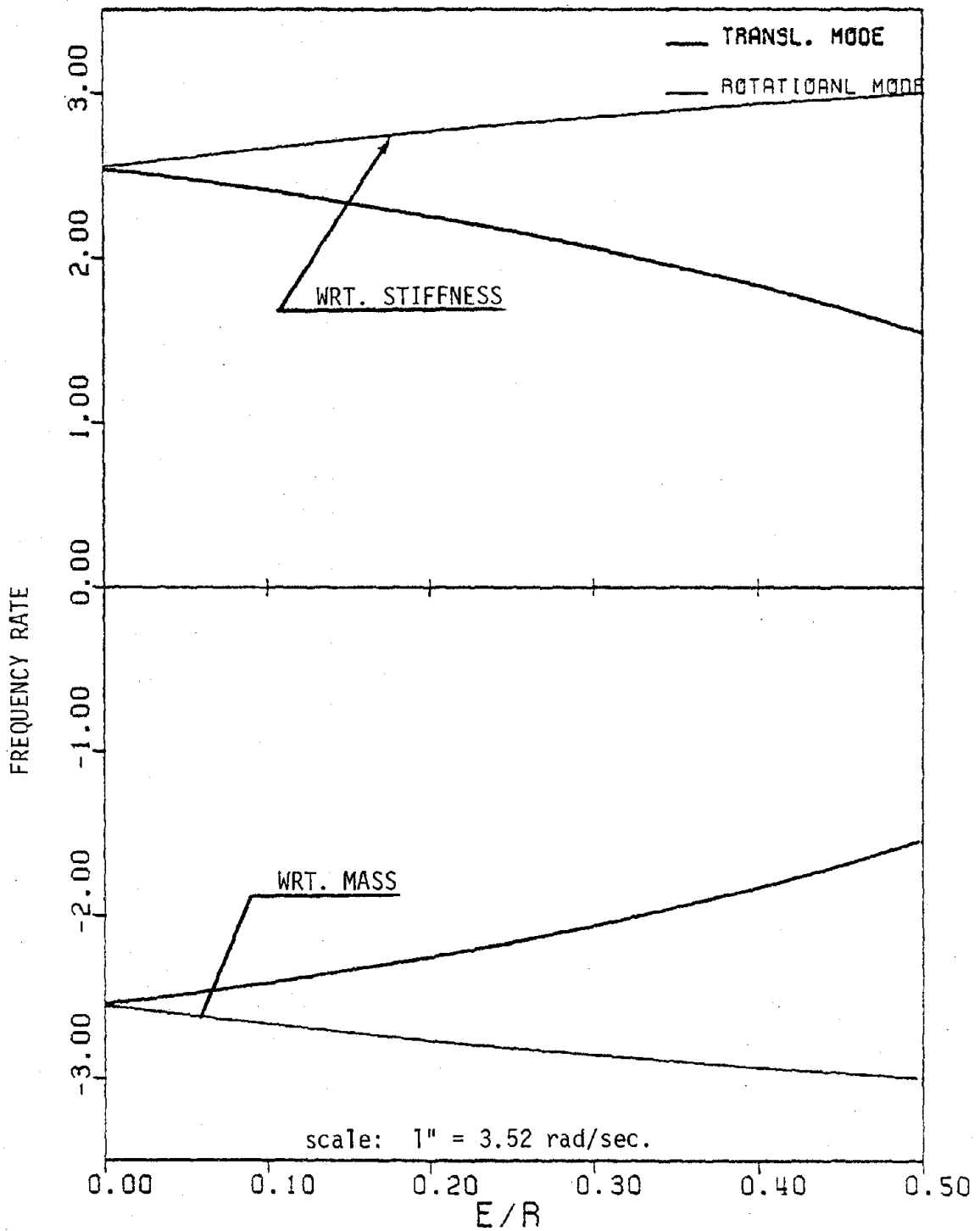

FIG. 4.2 RATES OF CHANGE OF LOWEST TRANSLATIONAL AND ROTATIONAL FREQUENCIES WITH RESPECT TO MASS AND STIFFNESS PARAMETERS.

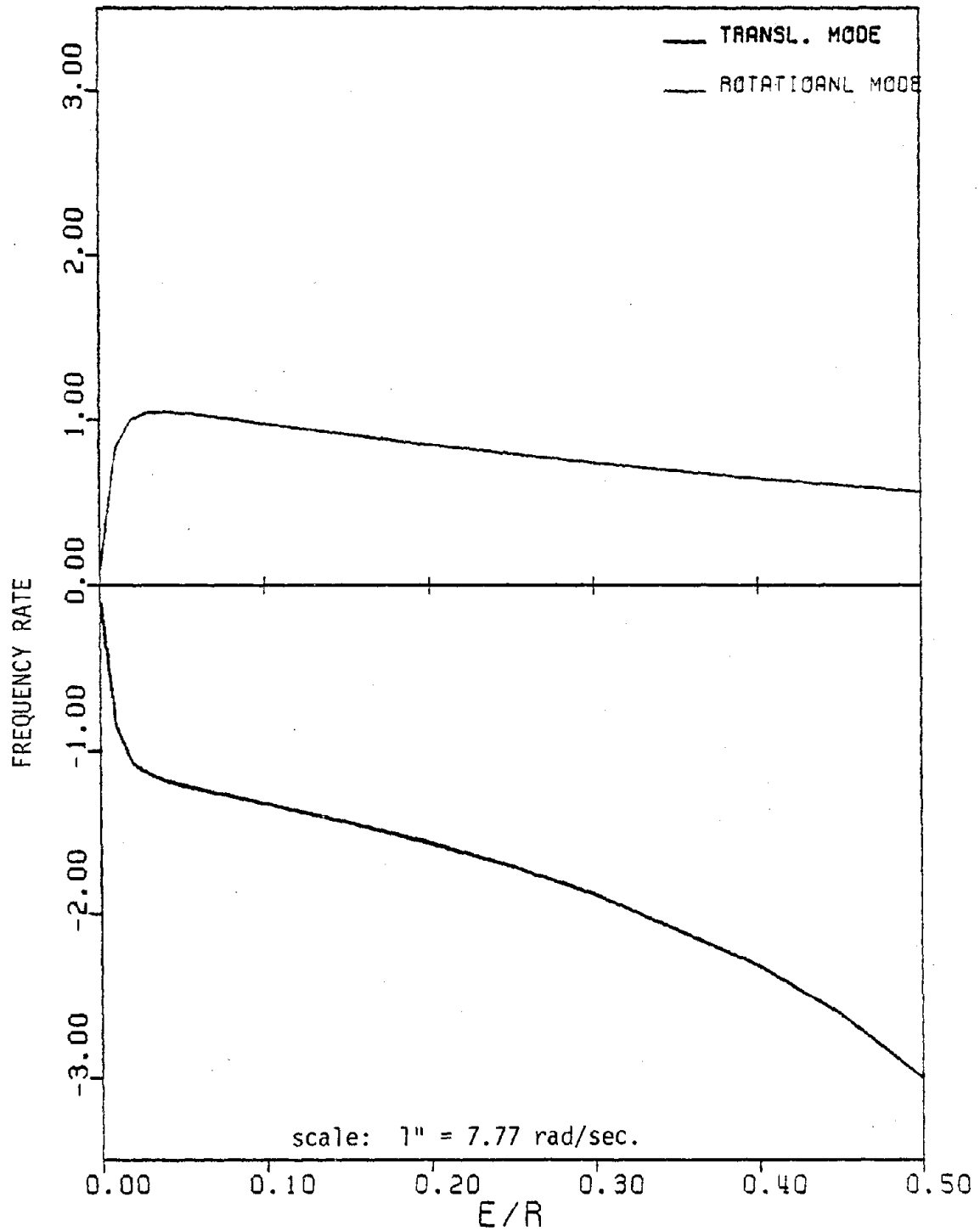

FIG. 4.3 RATES OF CHANGE OF LOWEST TRANSLATIONAL AND ROTATIONAL FREQUENCIES WITH RESPECT TO ECCENTRICITY PARAMETER

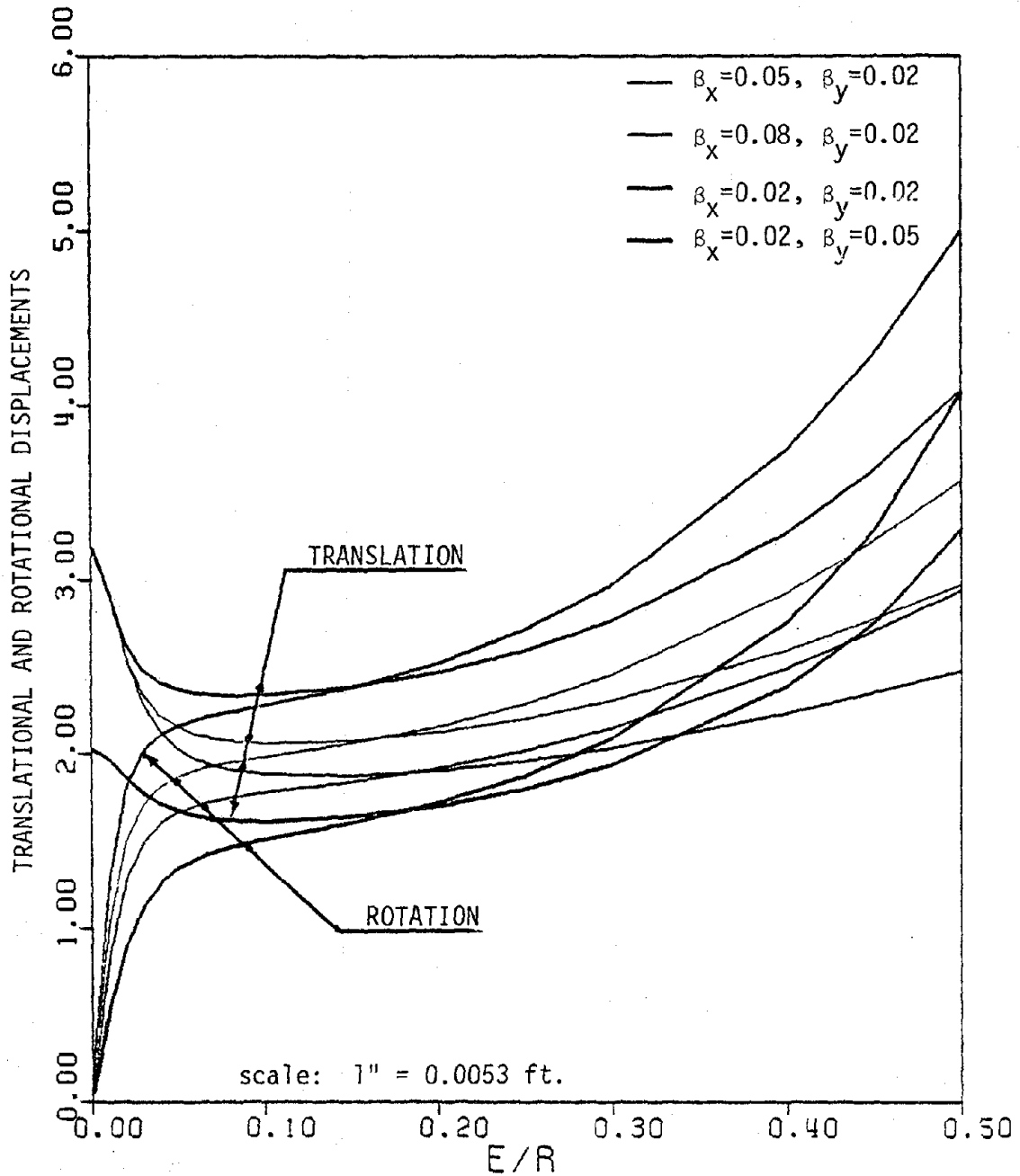

FIG. 4.4 ROOT MEAN SQUARE (RMS) RESPONSE OF TRANSLATIONAL AND ROTATIONAL (r_θ) DISPLACEMENTS OBTAINED BY COMPLEX MODE APPROACH.

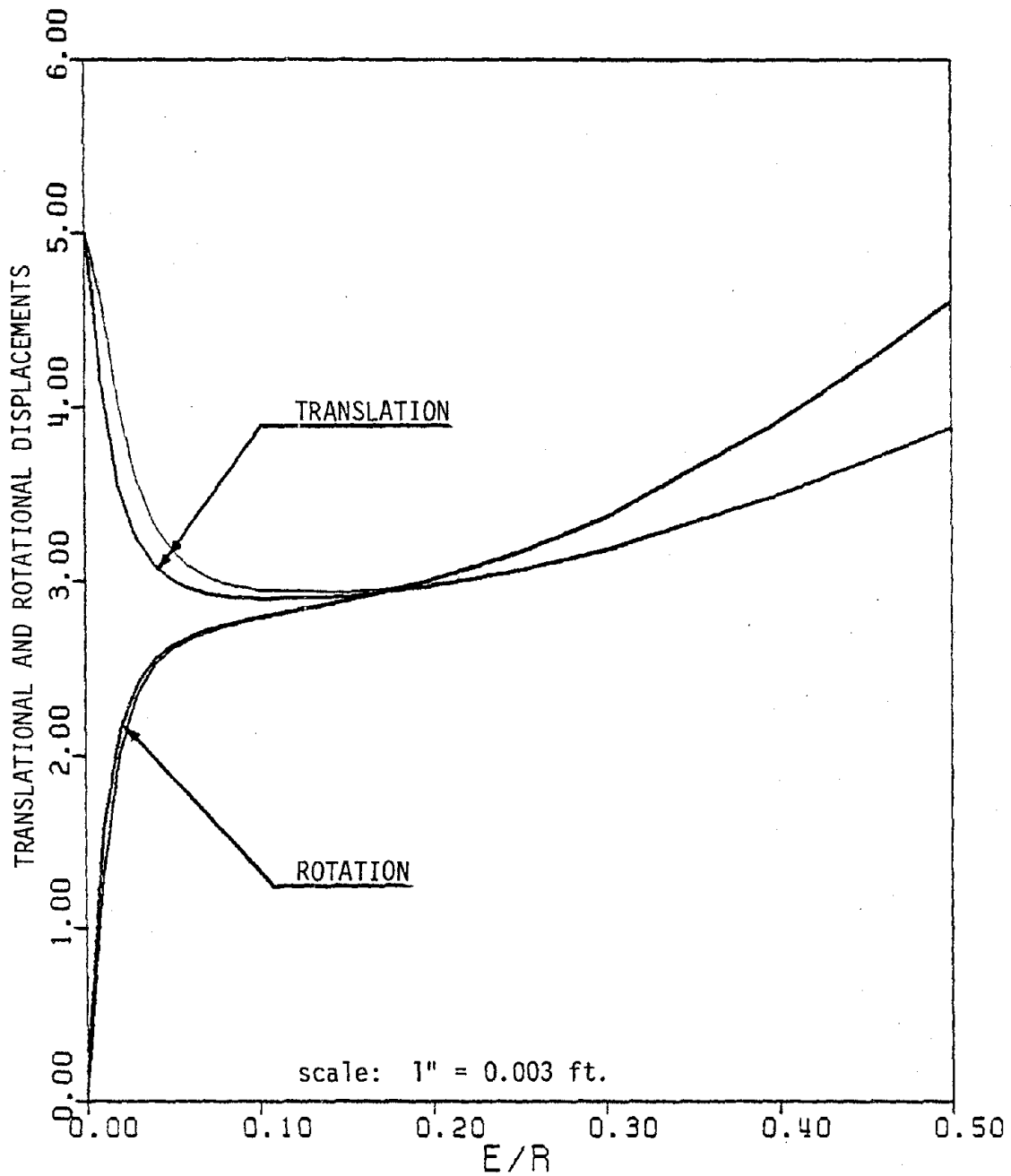

FIG. 4.5 RMS RESPONSE OF TRANSLATIONAL AND ROTATIONAL DISPLACEMENTS OBTAINED BY COMPLEX AND NORMAL MODE APPROACHES FOR $\beta_x=0.05$ AND $\beta_y=0.02$

REL. TRANSLATION : — COMPLEX MODE — NORMAL MODE
 ROTATION : — COMPLEX MODE — NORMAL MODE

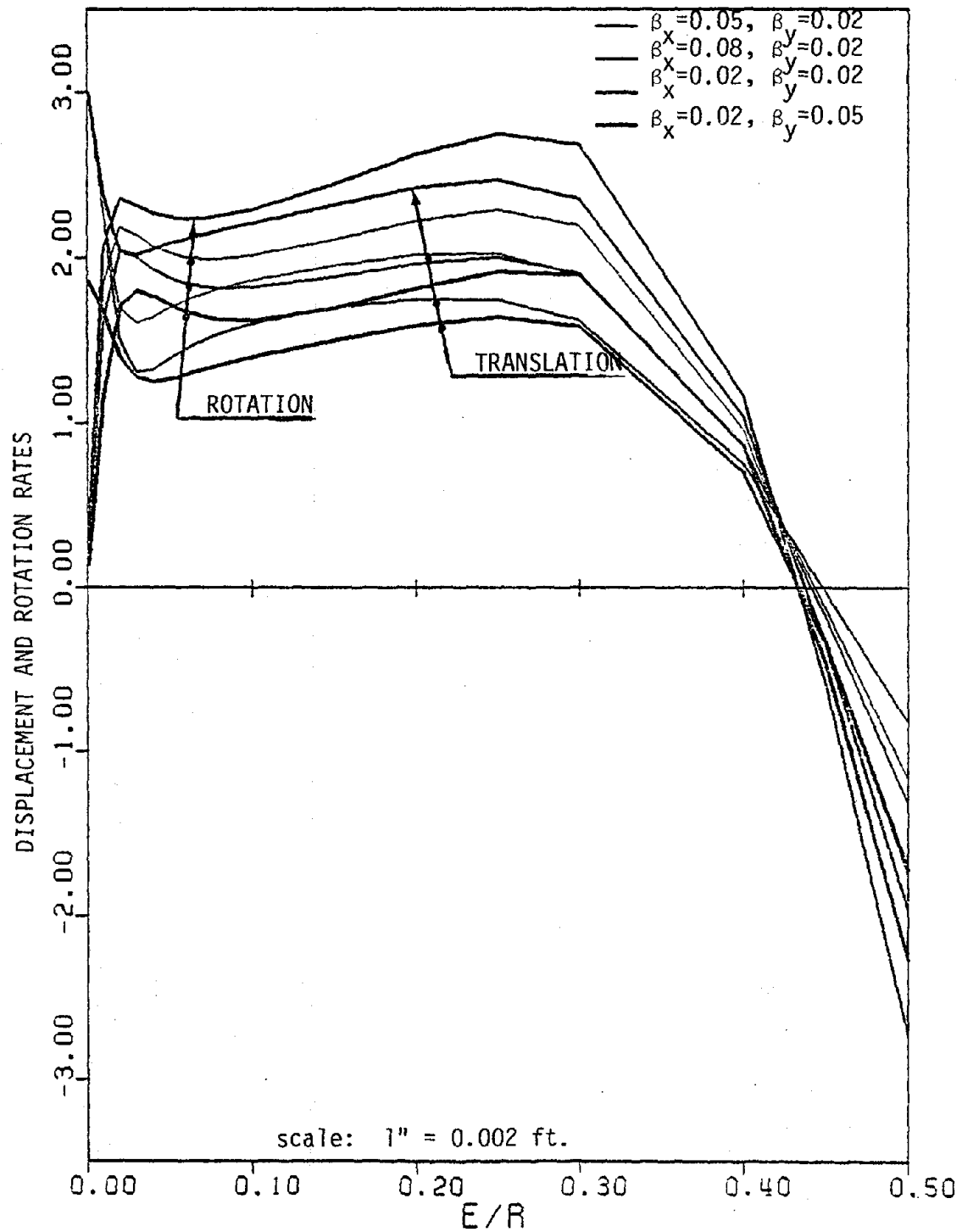

FIG. 4.6 RATES OF CHANGE OF RMS RESPONSE OF TRANSLATIONAL AND ROTATIONAL DISPLACEMENTS WITH RESPECT TO MASS PARAMETER.

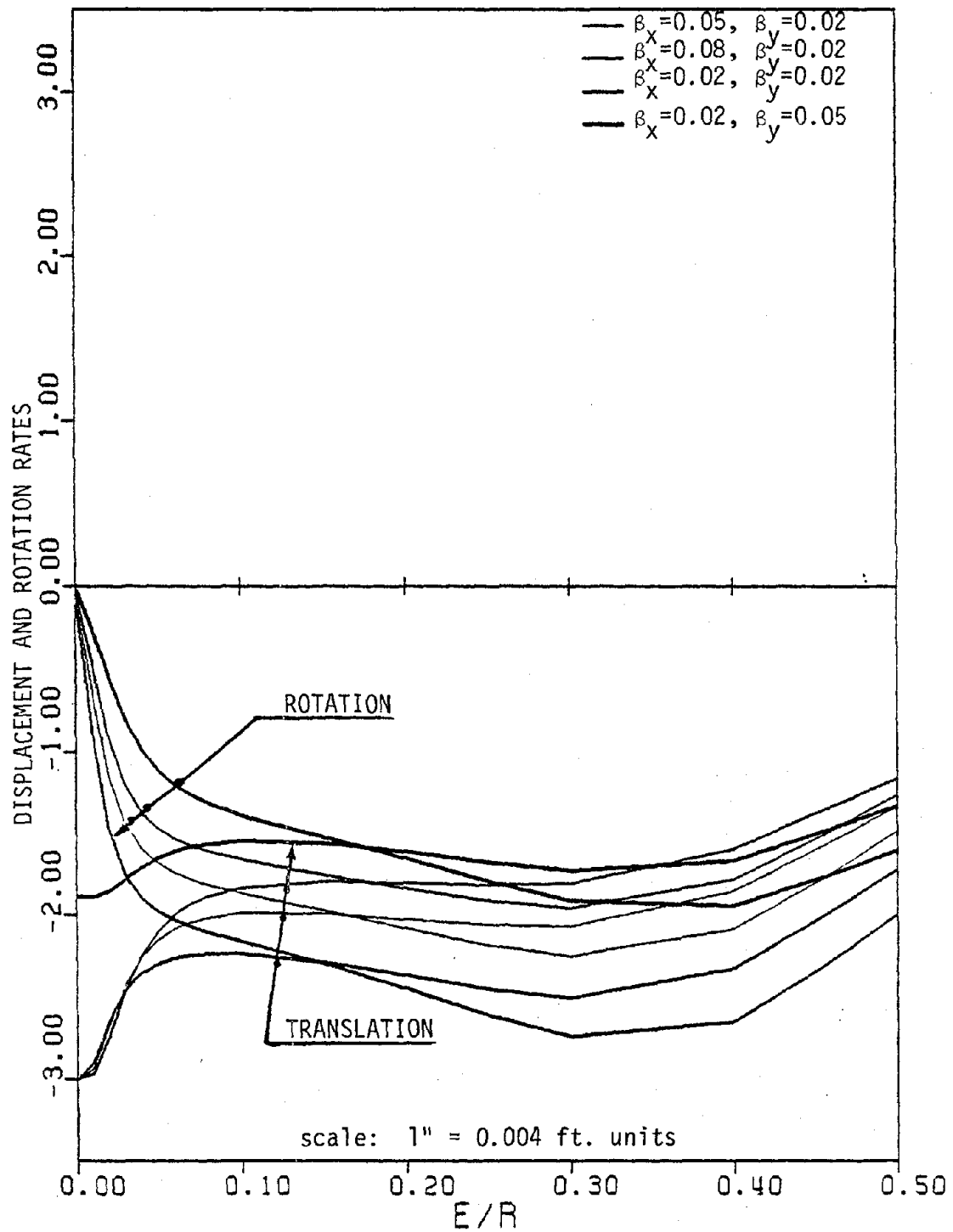

FIG. 4.7 RATES OF CHANGE OF RMS RESPONSE OF TRANSLATIONAL AND ROTATIONAL DISPLACEMENTS WITH RESPECT TO STIFFNESS PARAMETER.

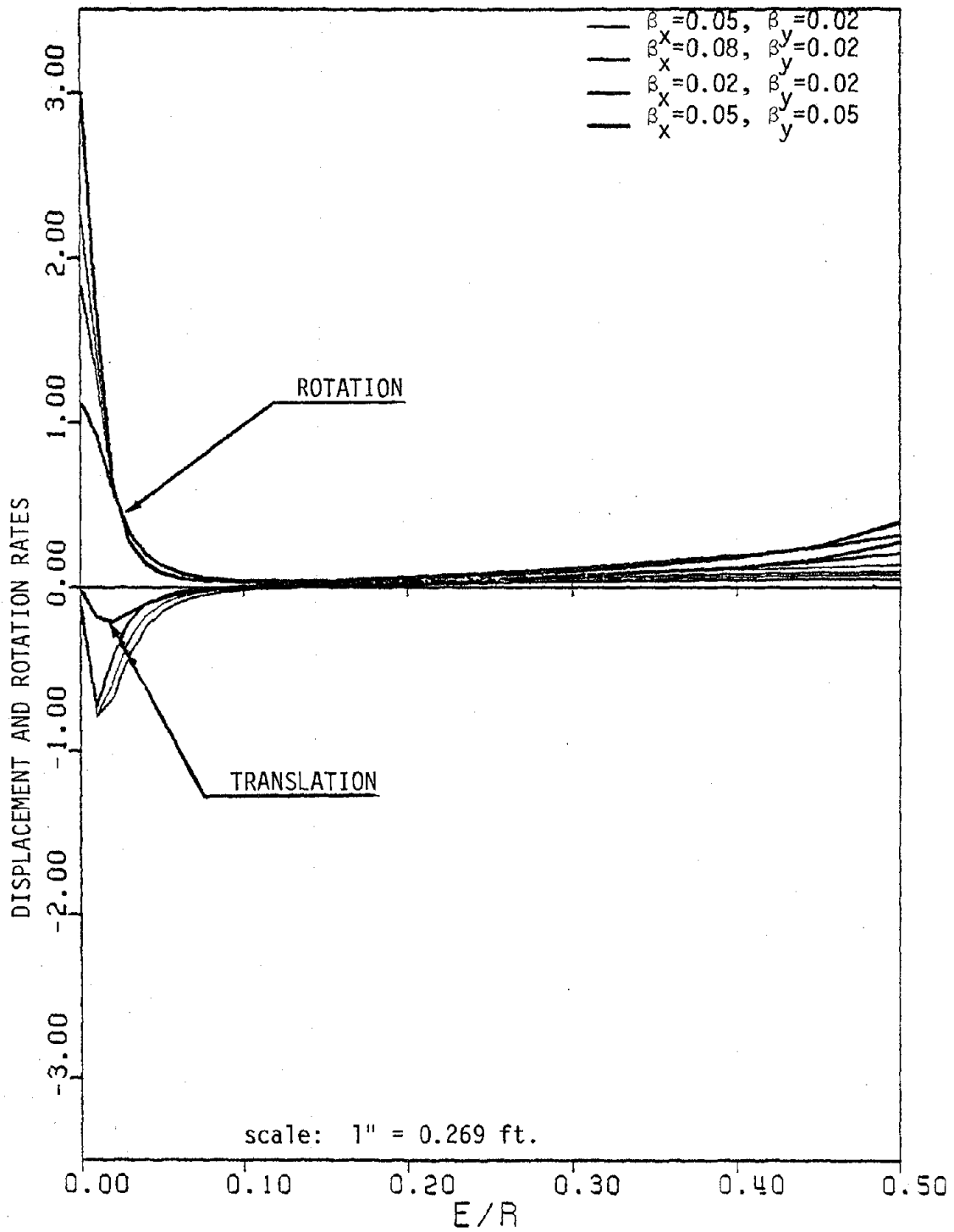

FIG. 4.8 RATES OF CHANGE OF RMS RESPONSE OF TRANSLATIONAL AND ROTATIONAL DISPLACEMENTS WITH RESPECT TO ECCENTRICITY PARAMETER.

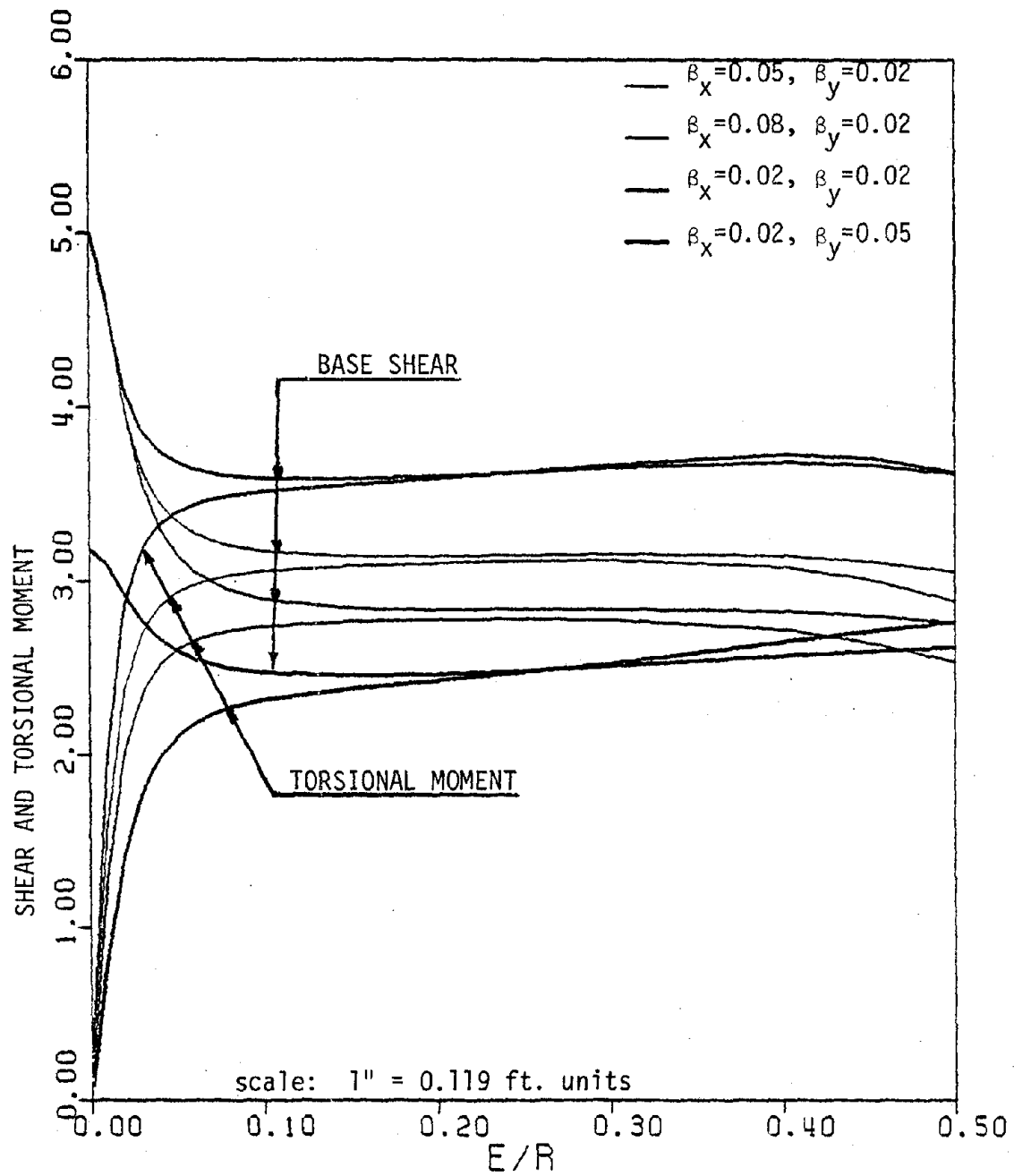

FIG. 4.9 RMS VALUES OF NORMALIZED BASE SHEAR AND TORSIONAL MOMENT OBTAINED BY COMPLEX MODE APPROACH.

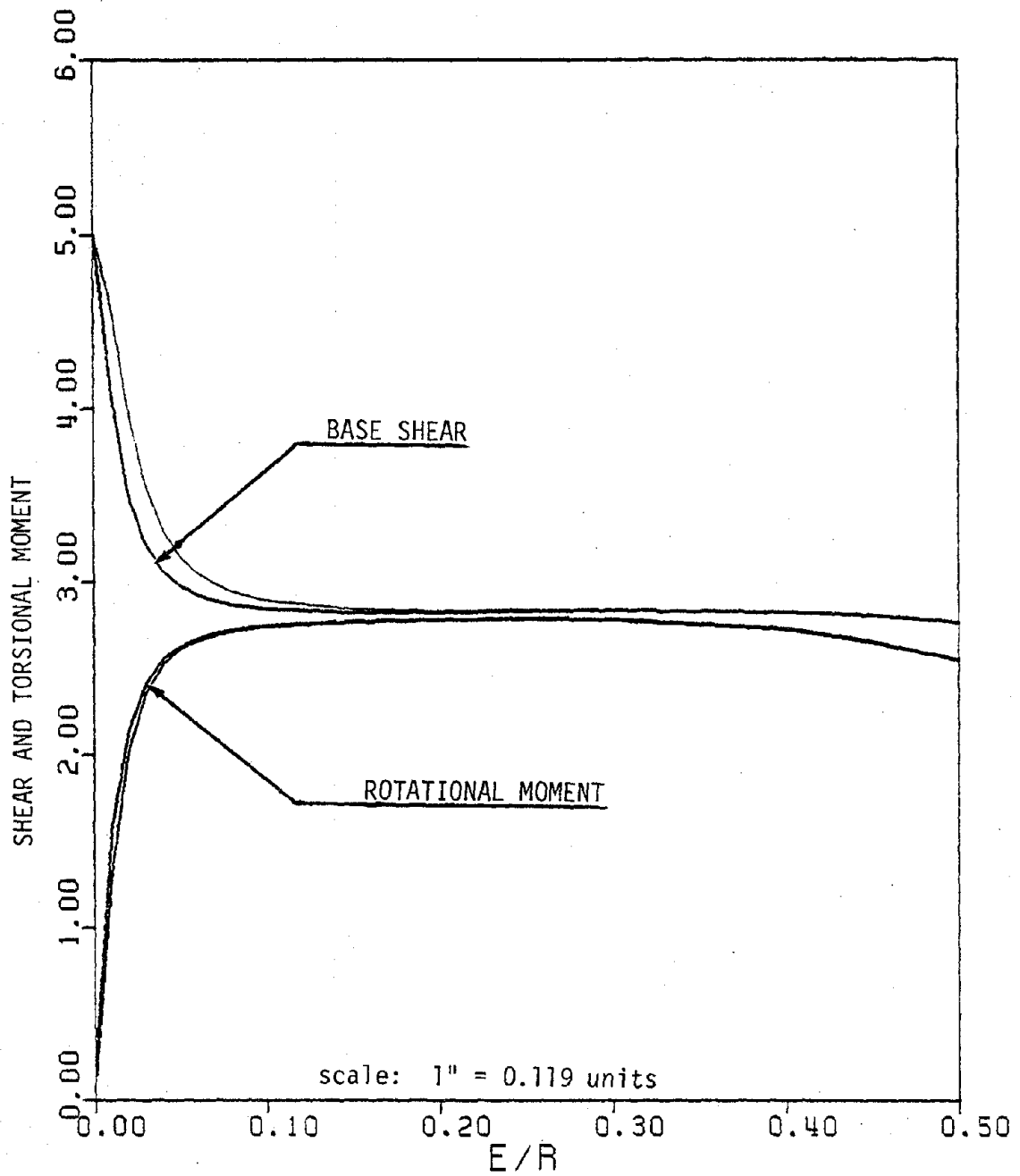

FIG. 4.10 RMS VALUES OF NORMALIZED BASE SHEAR AND TORSIONAL MOMENT OBTAINED BY COMPLEX AND NORMAL MODE APPROACH FOR $\beta_x = 0.08$ AND $\beta_y = 0.02$.

BASE SHEAR :	—	COMPLEX MODE	—	NORMAL MODE
TORSIONAL MOMENT :	—	COMPLEX MODE	—	NORMAL MODE

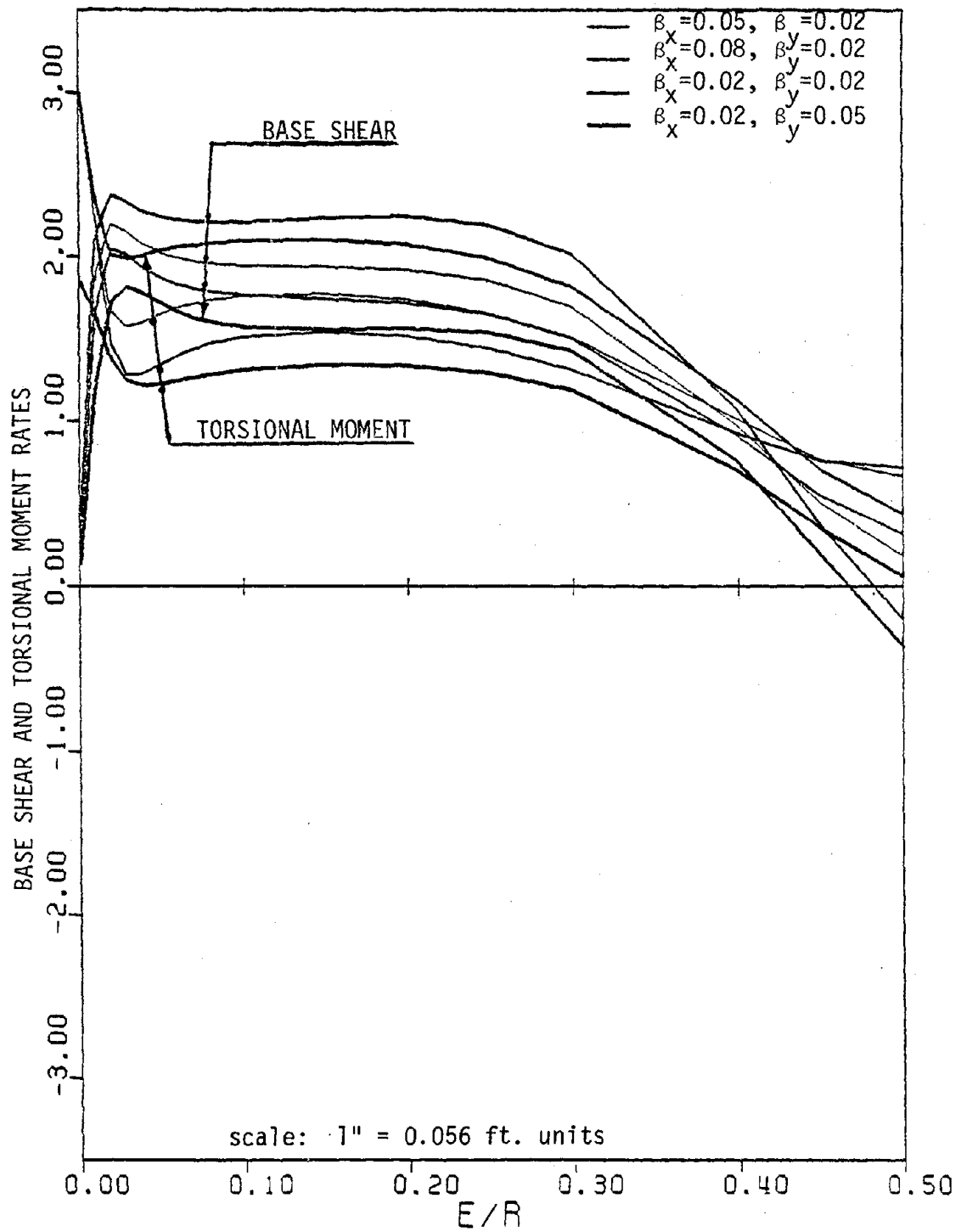

FIG. 4.11 RATES OF CHANGE OF RMS VALUES OF NORMALIZED BASE SHEAR AND TORSIONAL MOMENT WITH RESPECT TO MASS PARAMETER.

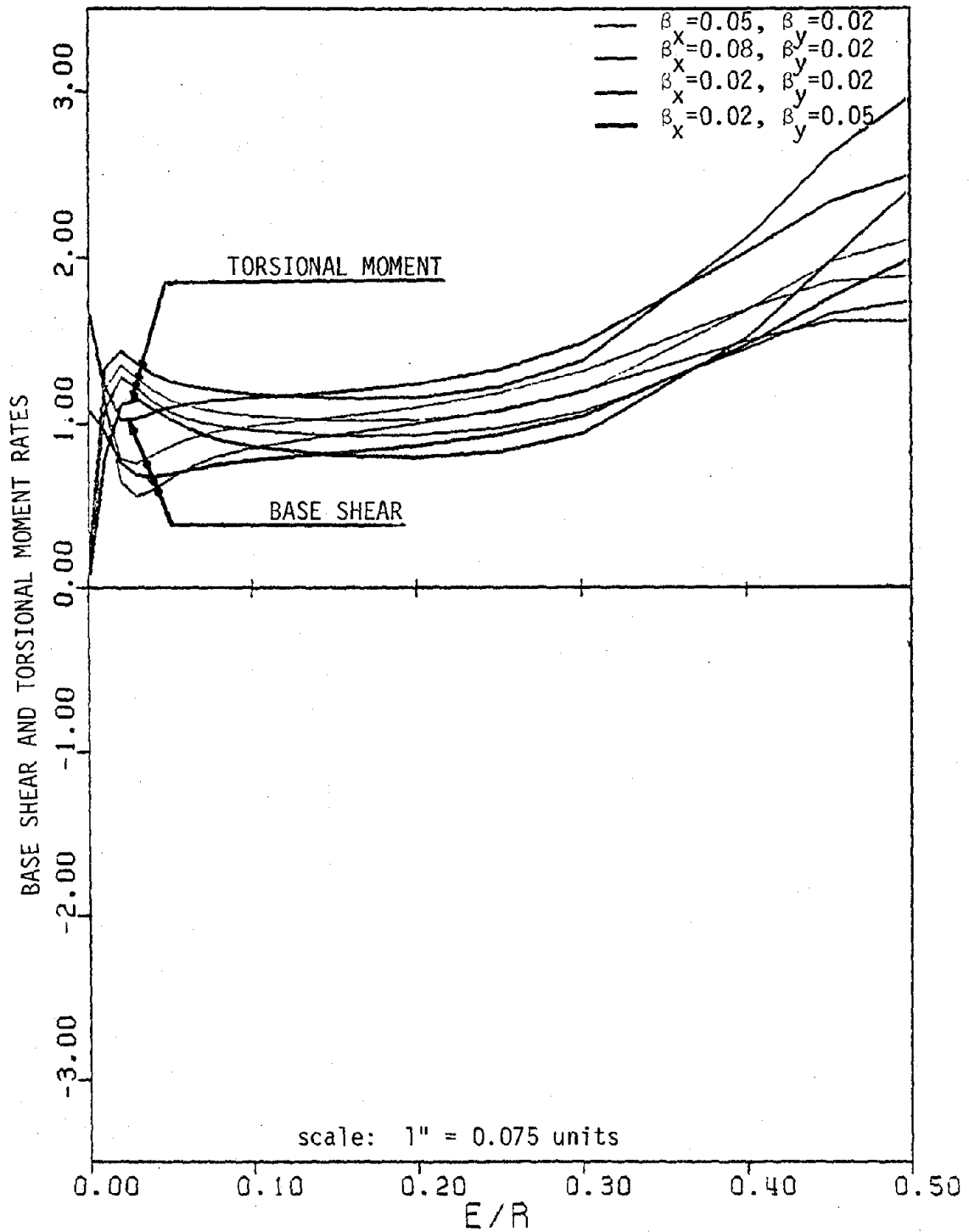

FIG. 4.12 RATES OF CHANGE OF RMS VALUES OF NORMALIZED BASE SHEAR AND TORSIONAL MOMENT WITH RESPECT TO STIFFNESS PARAMETER.

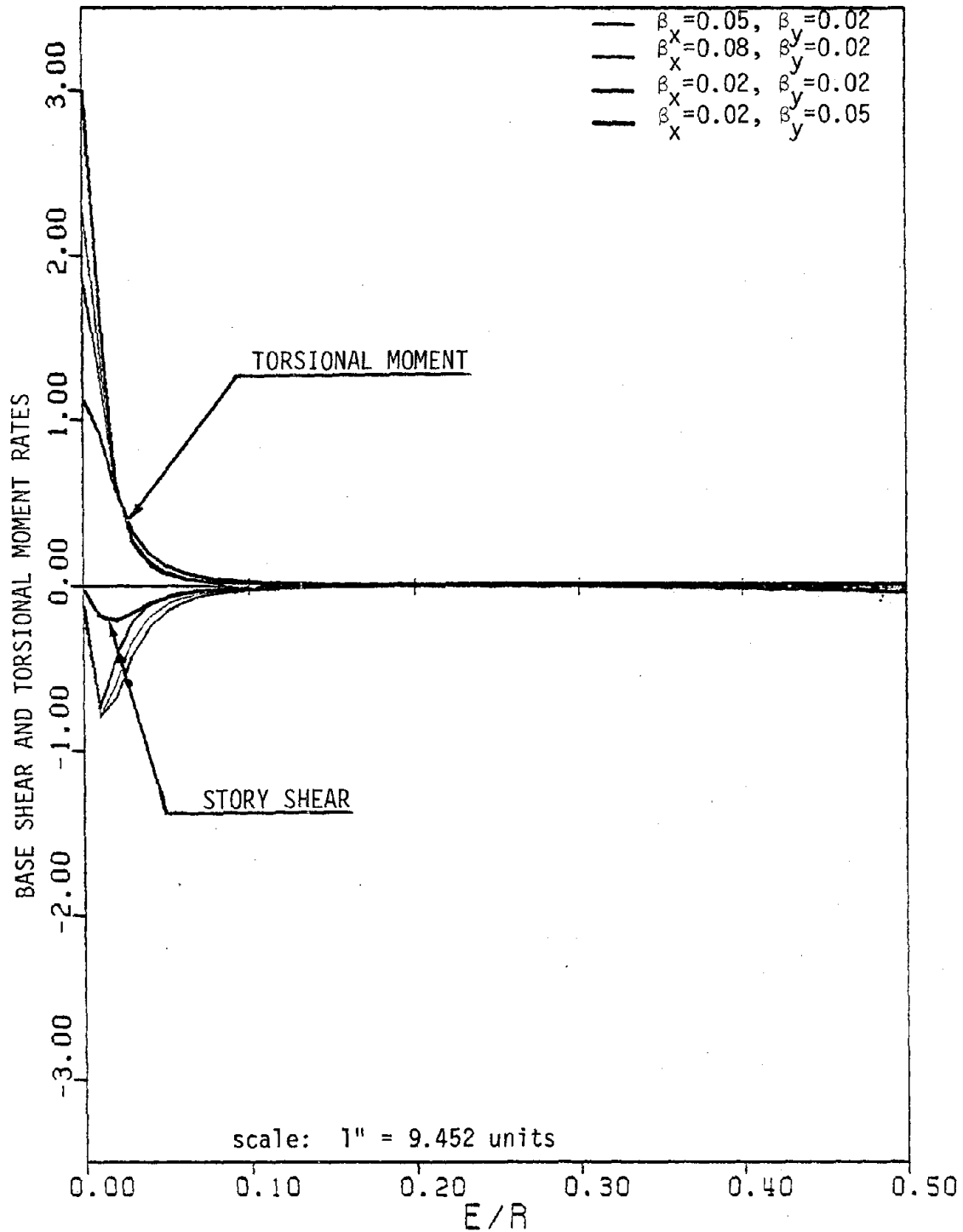

FIG. 4.13 RATES OF CHANGE OF RMS VALUES OF NORMALIZED BASE SHEAR AND TORSIONAL MOMENT WITH RESPECT TO ECCENTRICITY PARAMETER.

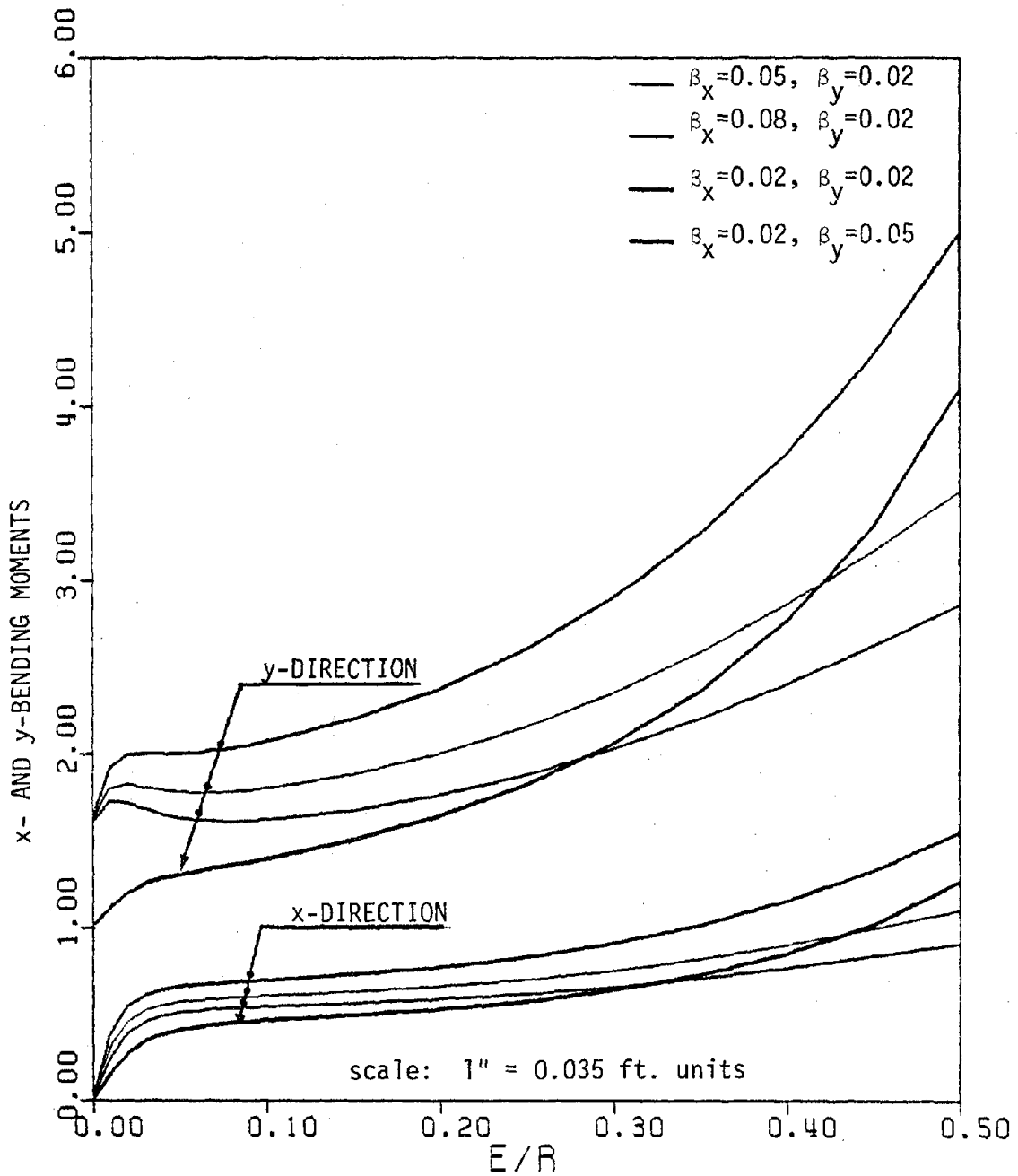

FIG. 4.14 RMS VALUES OF NORMALIZED BASE BENDING MOMENTS IN THE x- AND y-DIRECTIONS IN COLUMN 1 OF FIG. 2.2.

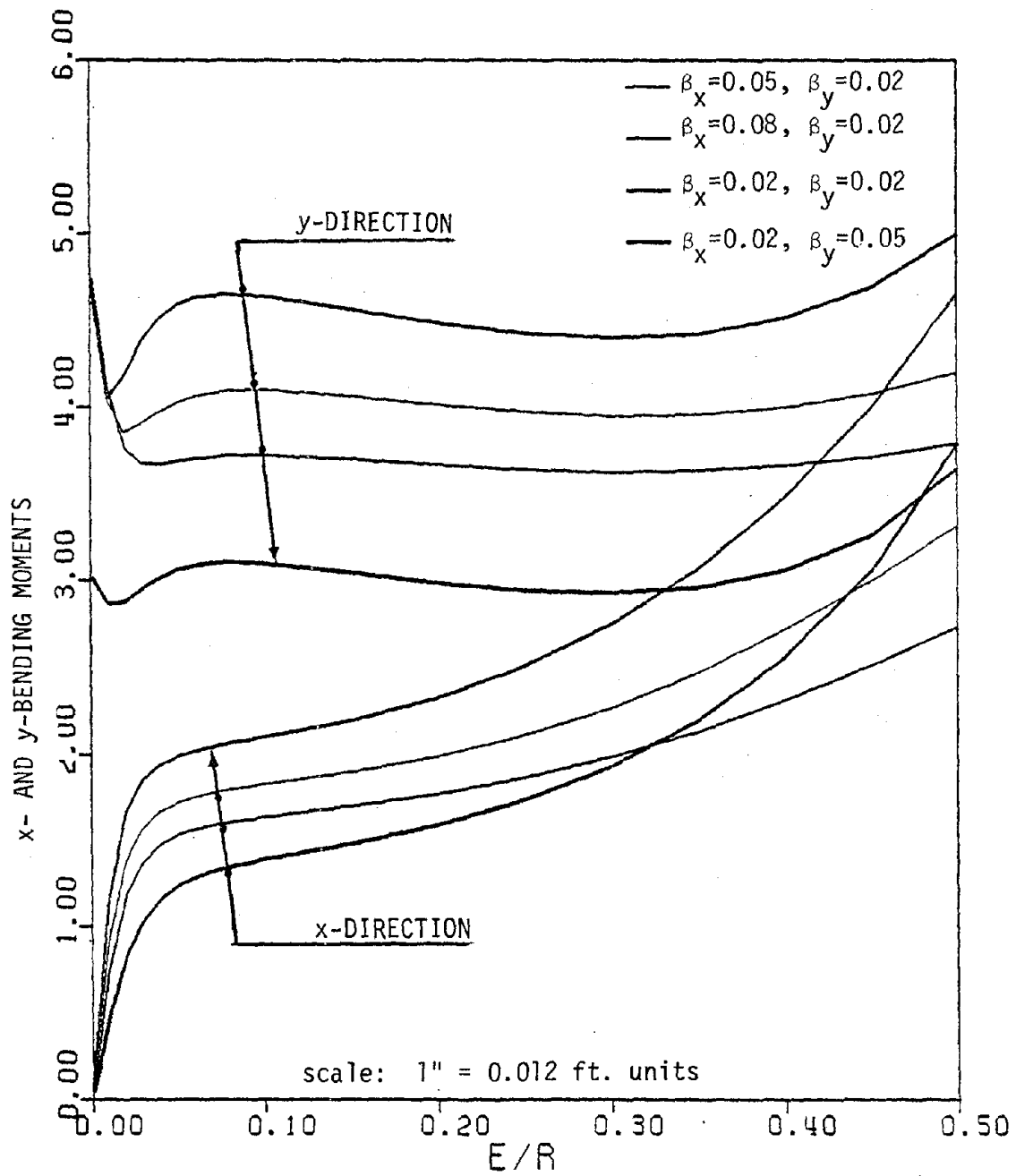

FIG. 4.15 RMS VALUES OF NORMALIZED BASE BENDING MOMENTS IN THE x- AND y-DIRECTIONS IN COLUMN 5 OF FIG. 2.2.

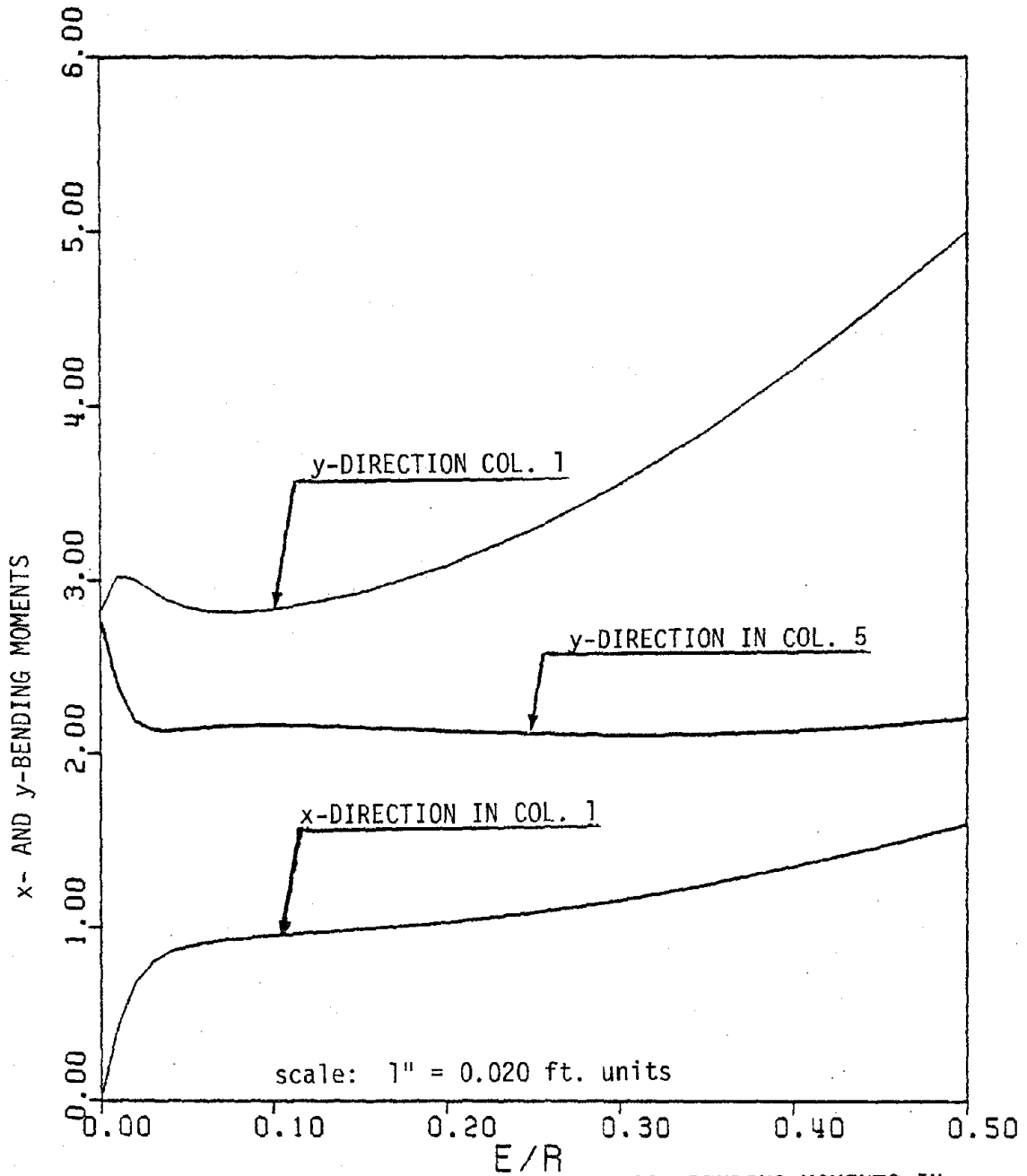

FIG. 4.16 RMS VALUES OF NORMALIZED BASE BENDING MOMENTS IN x- AND y-DIRECTIONS IN COLUMNS 1 AND 5 OF FIG. 2.2.

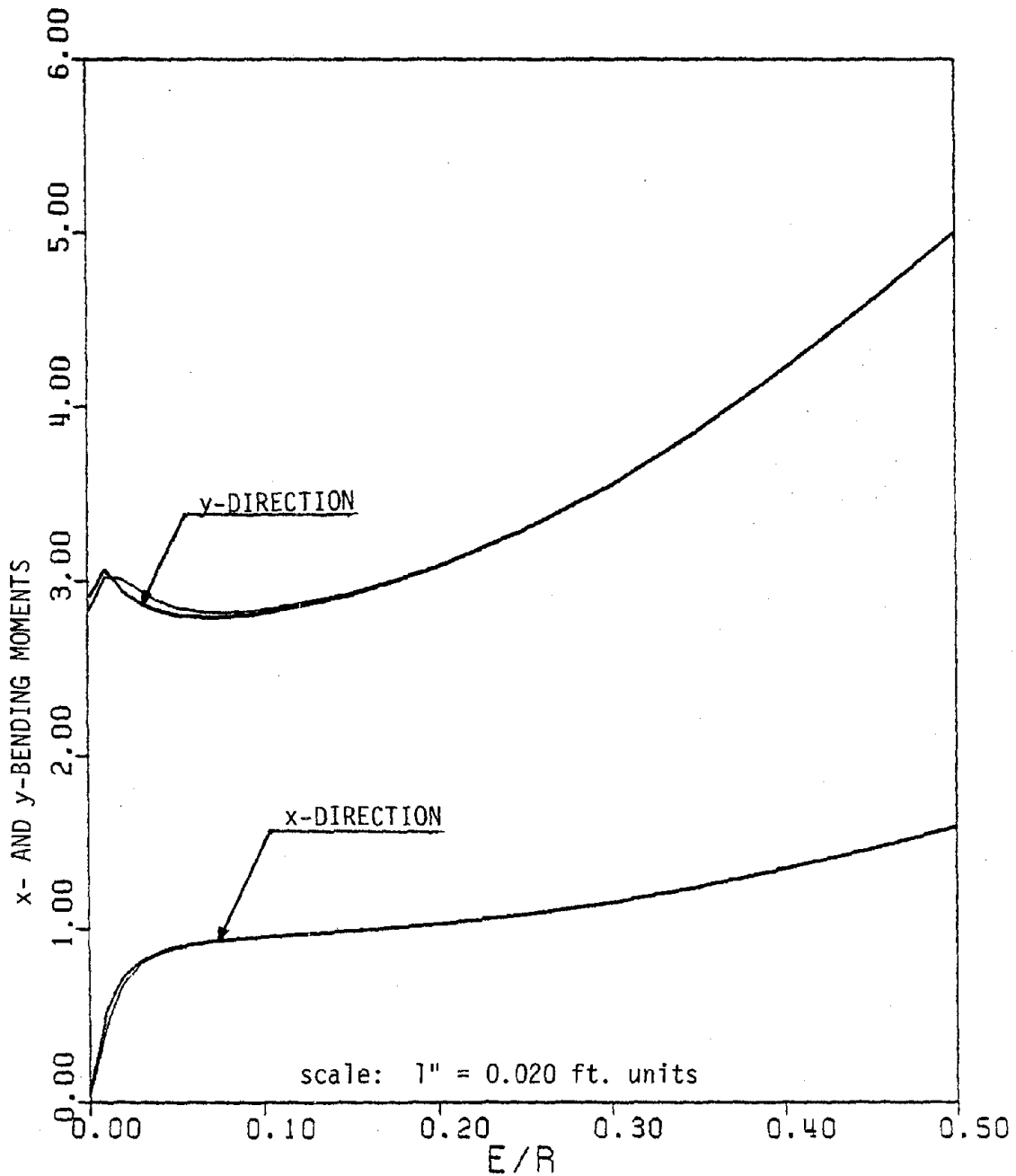

FIG. 4.17 RMS VALUES OF NORMALIZED BASE BENDING MOMENTS IN THE x- AND y-DIRECTIONS IN COLUMN 1 FOR $\beta_x = 0.08$ AND $\beta_y = 0.02$.

X- BENDING MOMENT: ——— COMPLEX MODE ——— NORMAL MODE
 Y- BENDING MOMENT: ——— COMPLEX MODE ——— NORMAL MODE

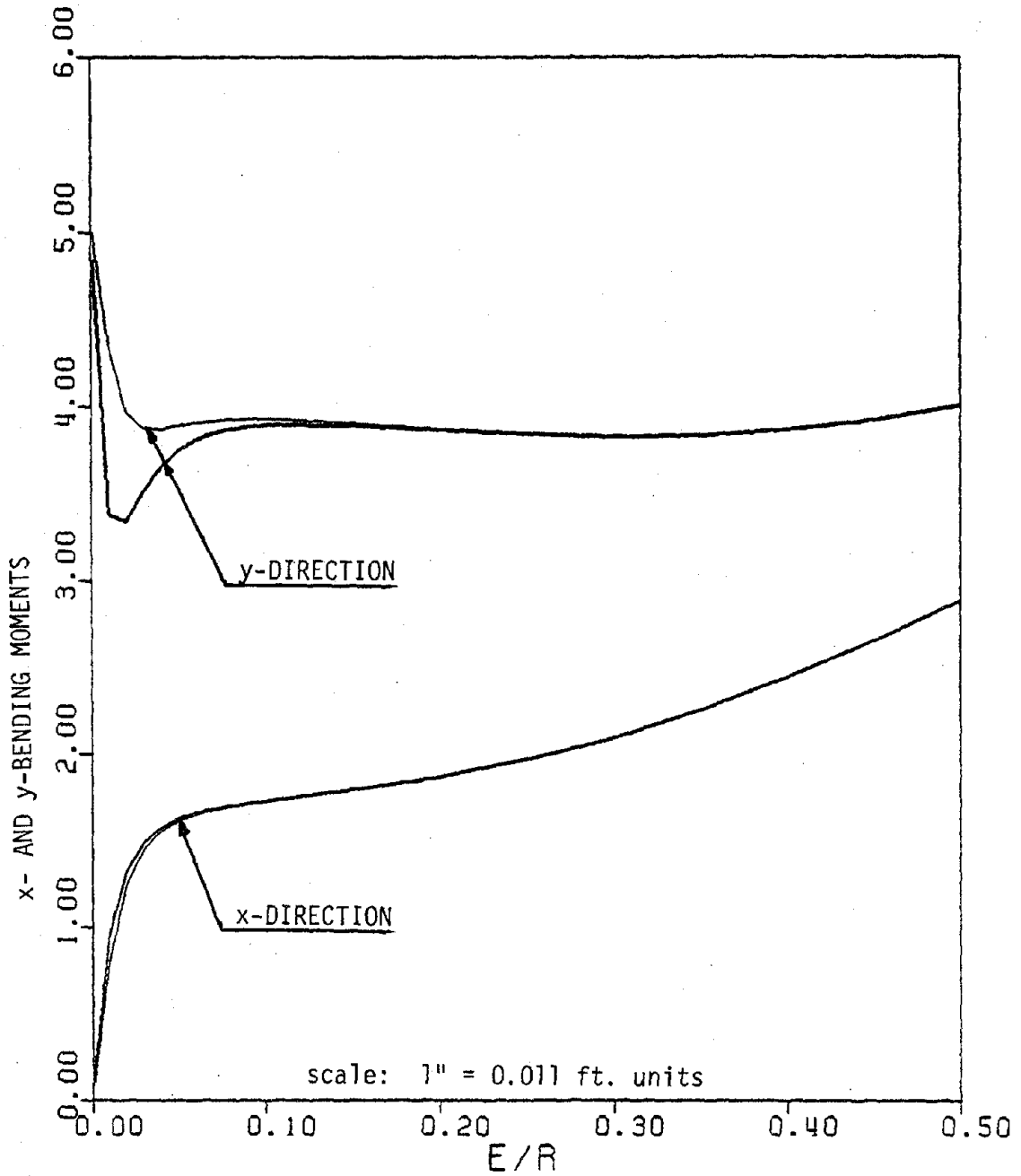

FIG. 4.18 RMS VALUES OF NORMALIZED BASE BENDING MOMENTS IN x- AND y-DIRECTIONS IN COLUMN 5 FOR $\beta_x=0.08$ AND $\beta_y=0.02$

X- BENDING MOMENT: — COMPLEX MODE — NORMAL MODE
 Y- BENDING MOMENT: — COMPLEX MODE — NORMAL MODE

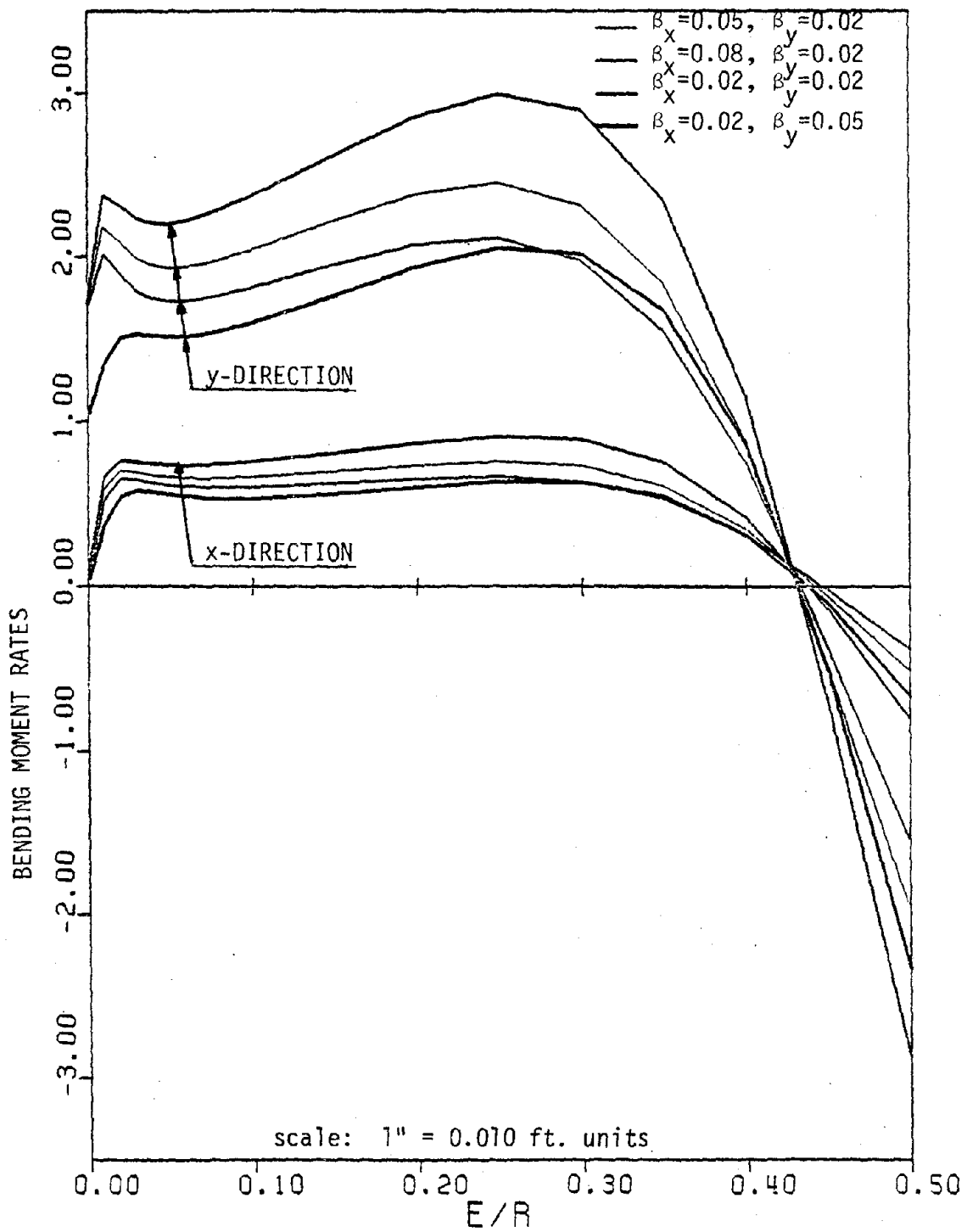

FIG. 4.19 RATES OF CHANGE OF RMS VALUES OF NORMALIZED BASE BENDING MOMENTS IN x- AND y-DIRECTIONS FOR COLUMN 1 WITH RESPECT TO MASS PARAMETER.

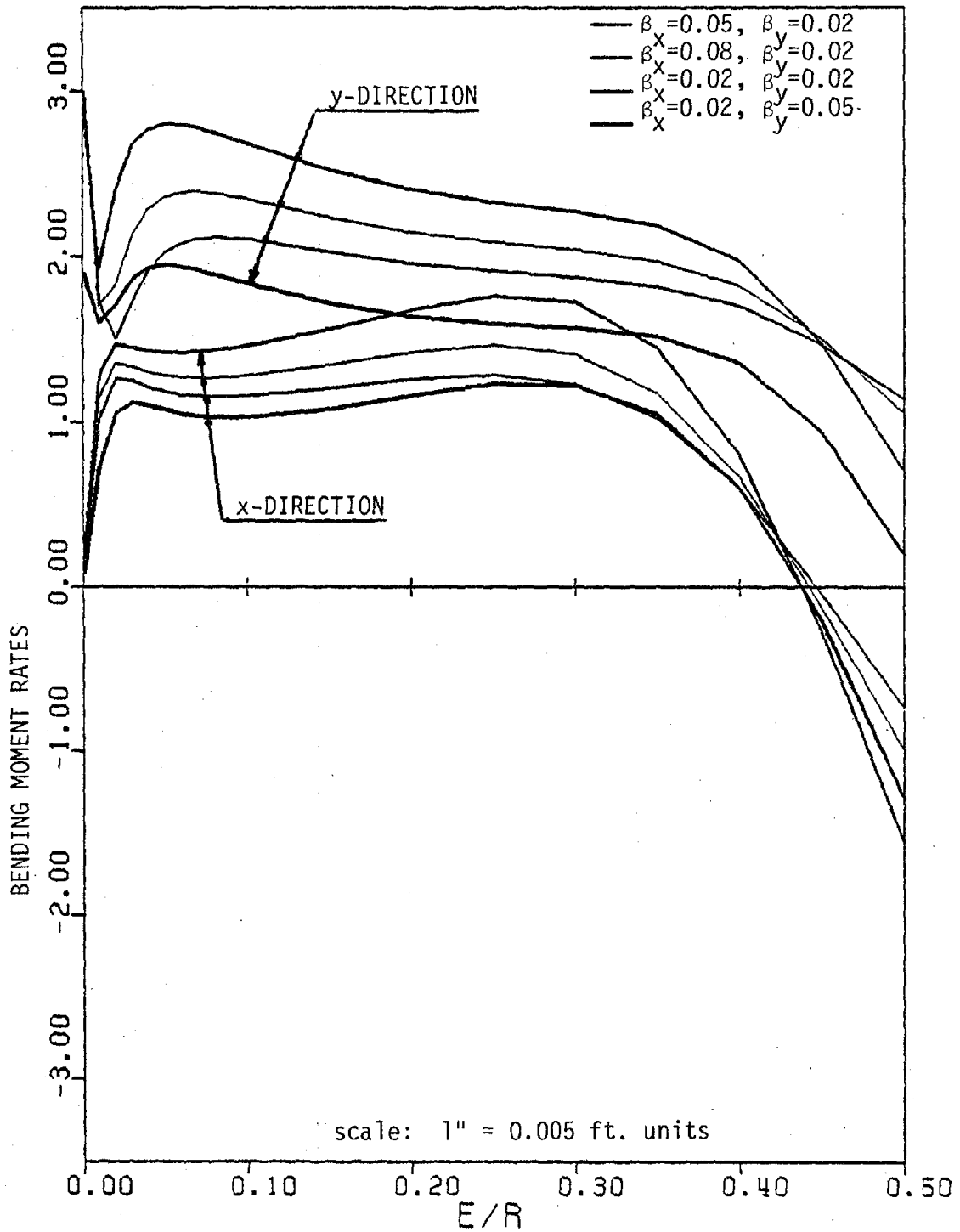

FIG. 4.20 RATES OF CHANGE OF RMS VALUES OF NORMALIZED BASE BENDING MOMENTS IN x- AND y-DIRECTIONS FOR COLUMN 5 WITH RESPECT TO MASS PARAMETER.

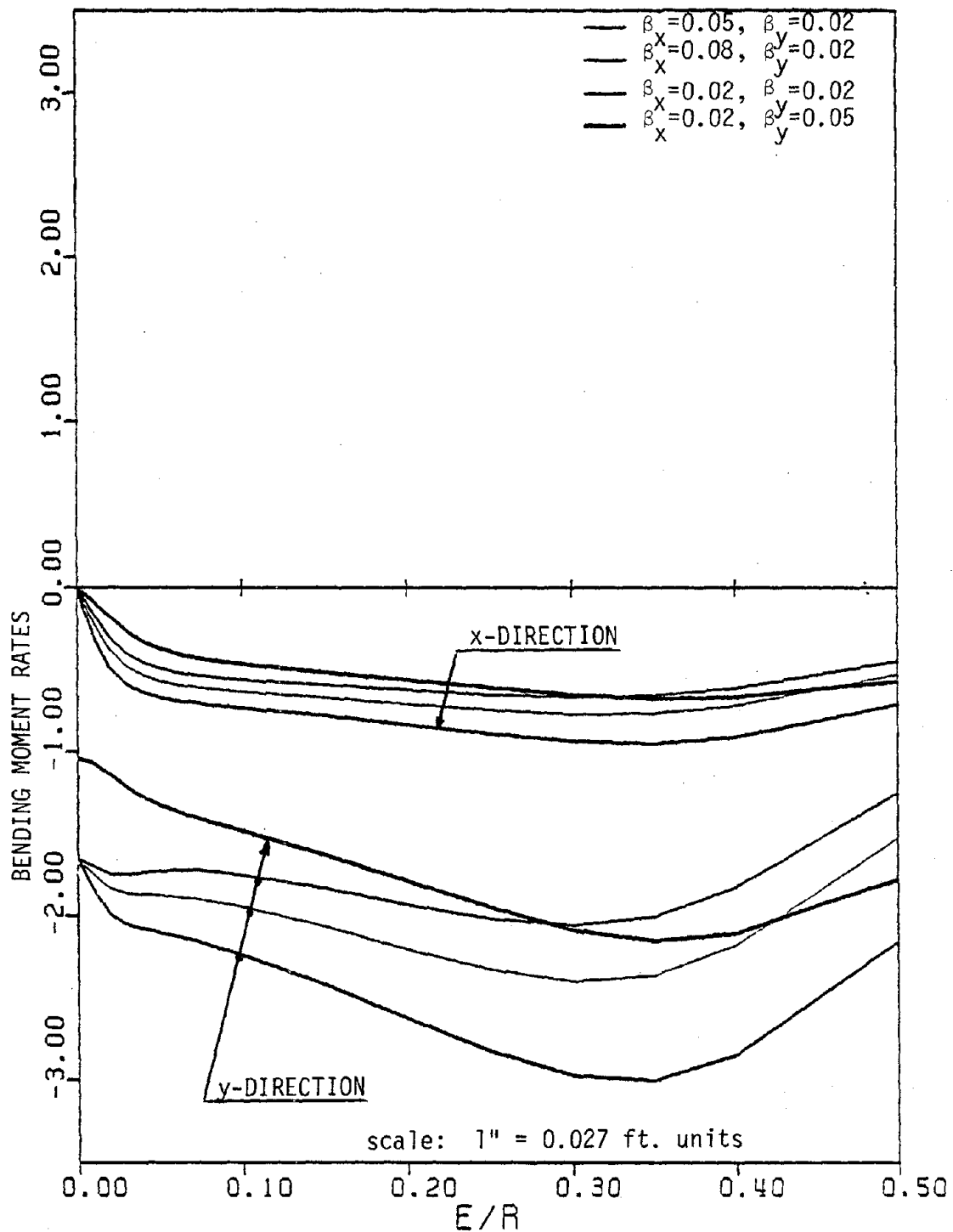

FIG. 4.21 RATES OF CHANGE OF RMS VALUES OF NORMALIZED BASE BENDING MOMENTS IN x- AND y-DIRECTIONS FOR COLUMN 1 WITH RESPECT TO STIFFNESS PARAMETER.

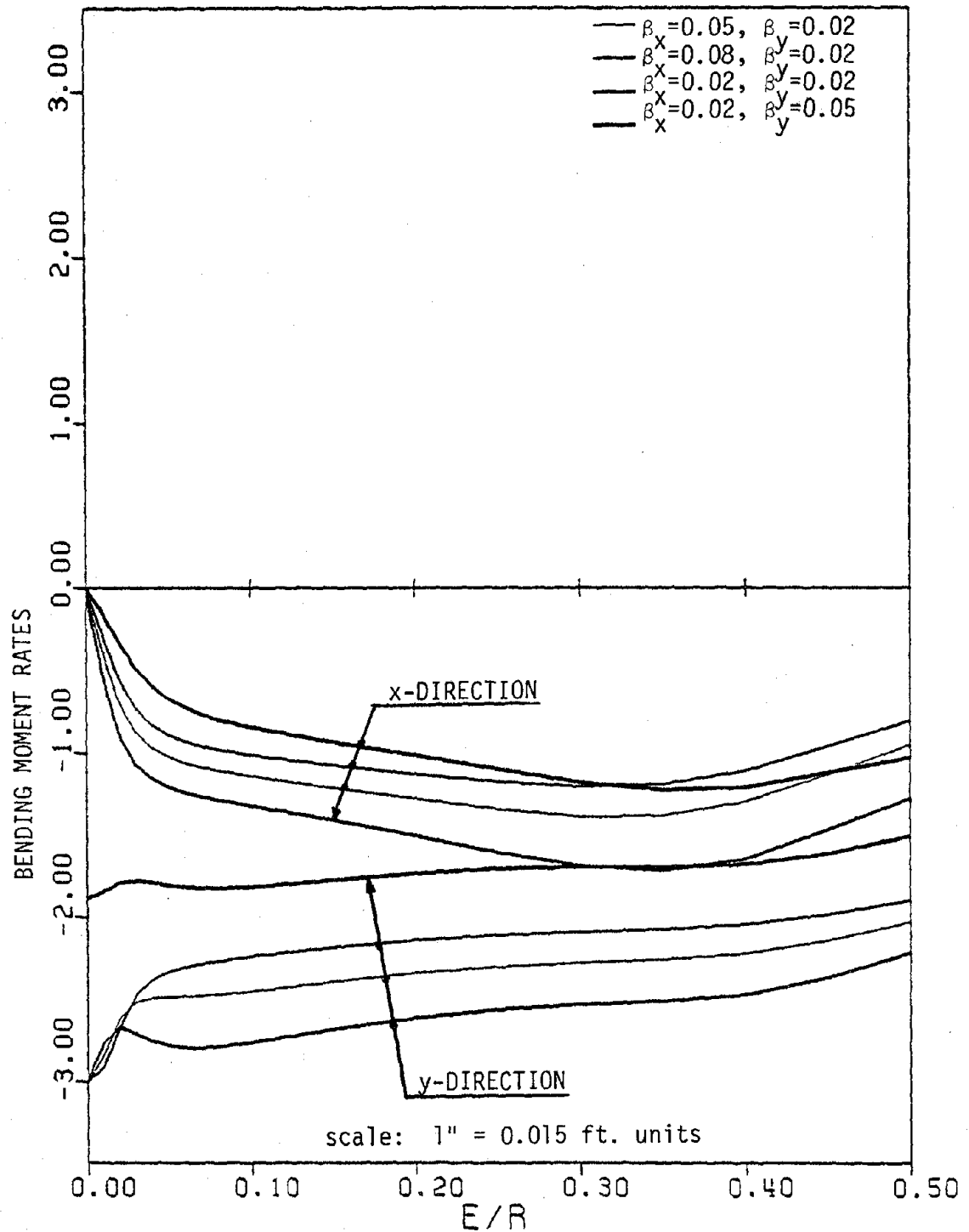

FIG. 4.22 RATES OF CHANGE OF RMS VALUES OF NORMALIZED BASE BENDING MOMENTS IN x- AND y-DIRECTIONS FOR COLUMN 5 WITH RESPECT TO STIFFNESS PARAMETER.

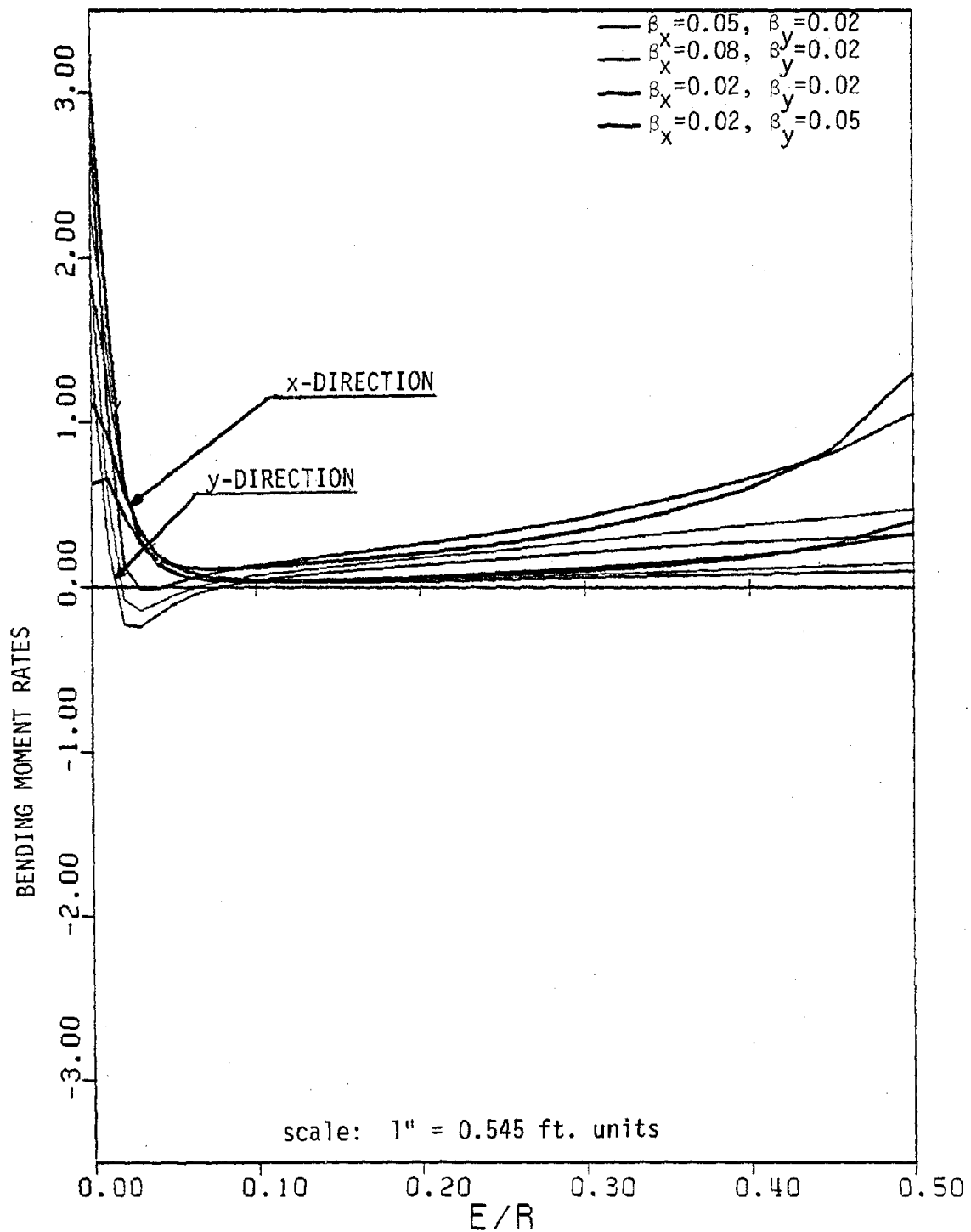

FIG. 4.23 RATES OF CHANGE OF RMS VALUES OF NORMALIZED BASE BENDING MOMENTS IN THE x- AND y-DIRECTIONS FOR COLUMN 1 WITH RESPECT TO ECCENTRICITY PARAMETER.

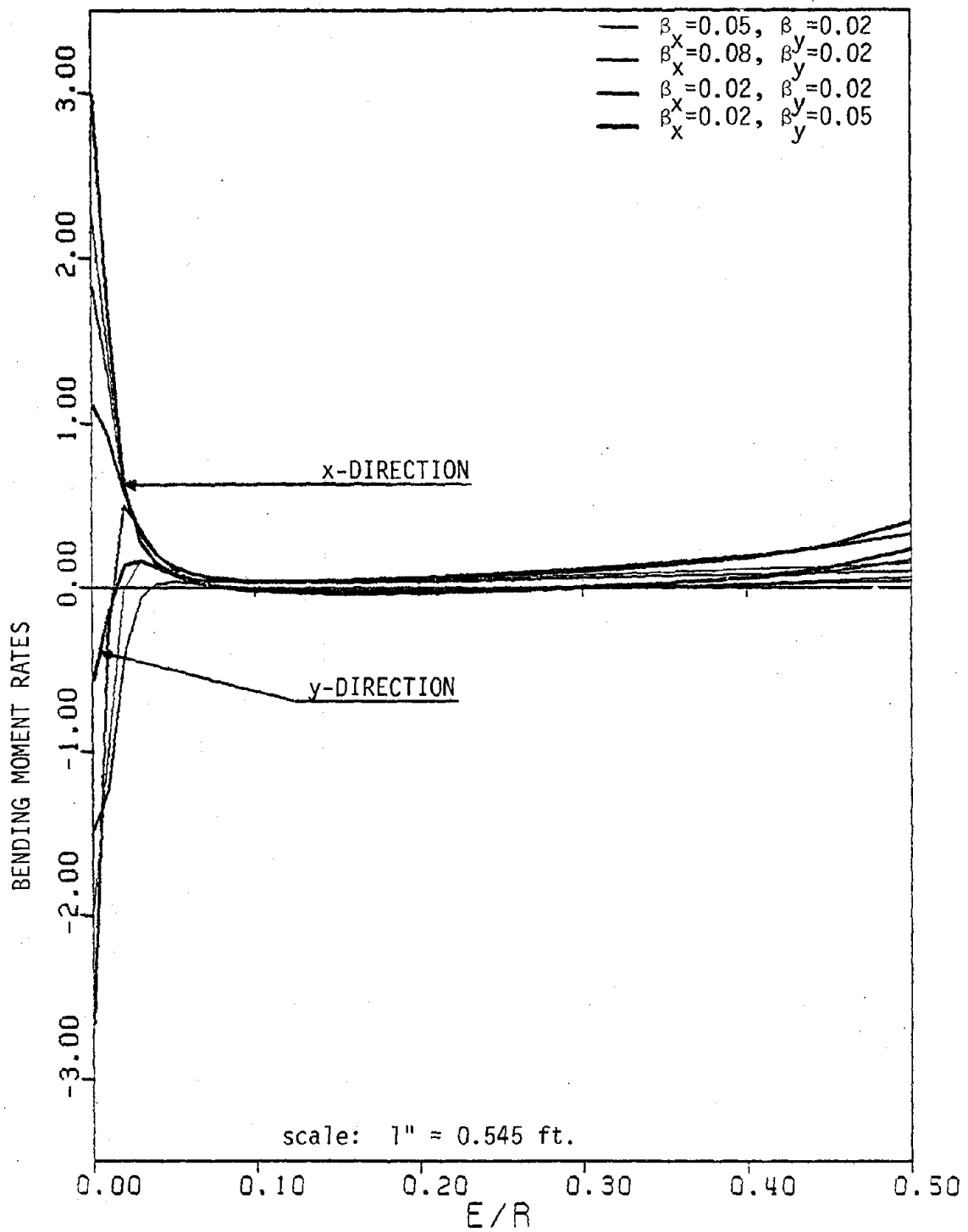

FIG. 4.24 RATES OF CHANGE OF RMS VALUES OF NORMALIZED BASE BENDING MOMENTS IN x- AND y-DIRECTIONS FOR COLUMN 5 WITH RESPECT TO ECCENTRICITY PARAMETER.

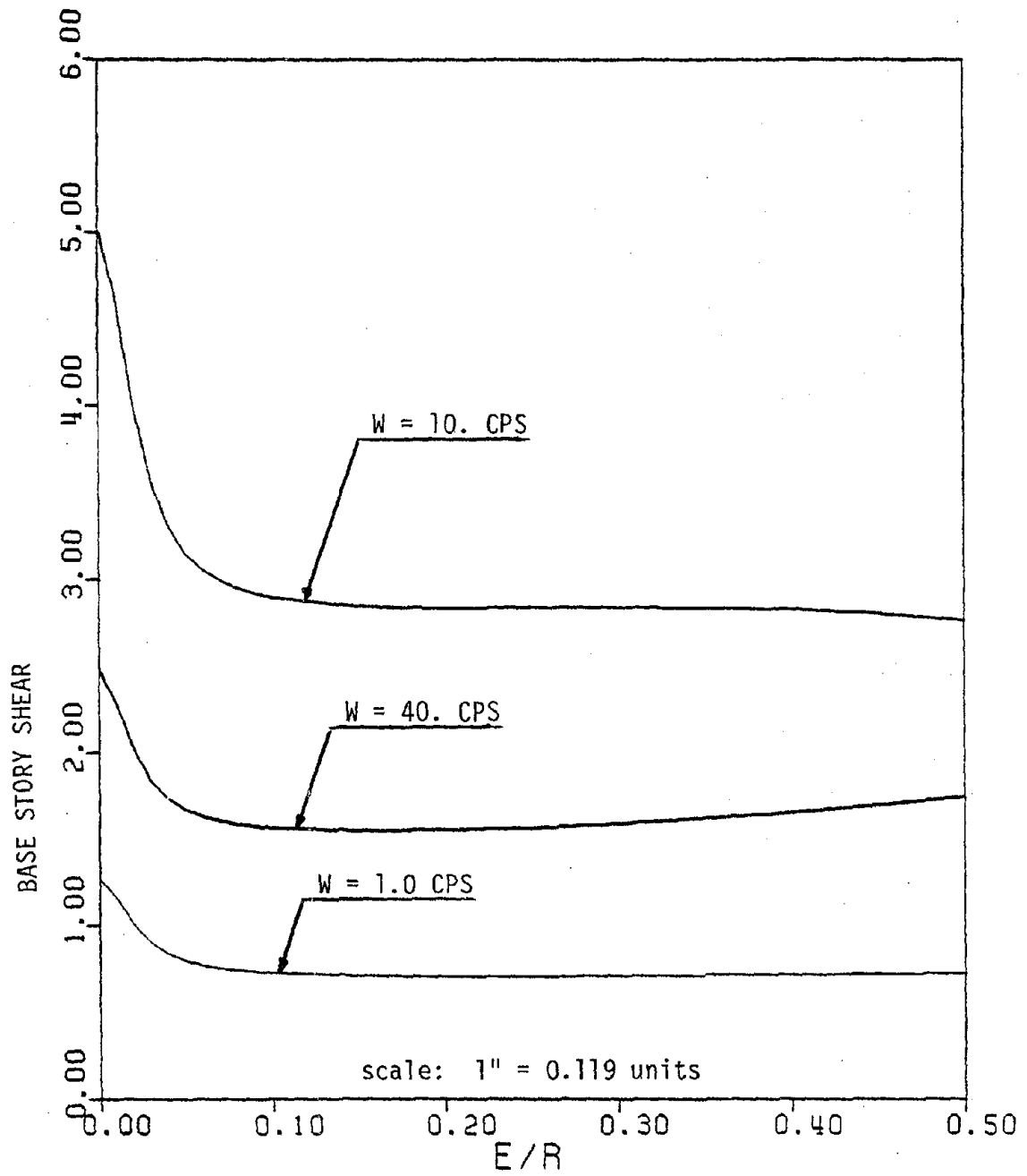

FIG. 4. 25 RMS VALUES OF NORMALIZED BASE SHEAR FOR FREQUENCY PARAMETER VALUES OF 1, 10 AND 40 CPS.

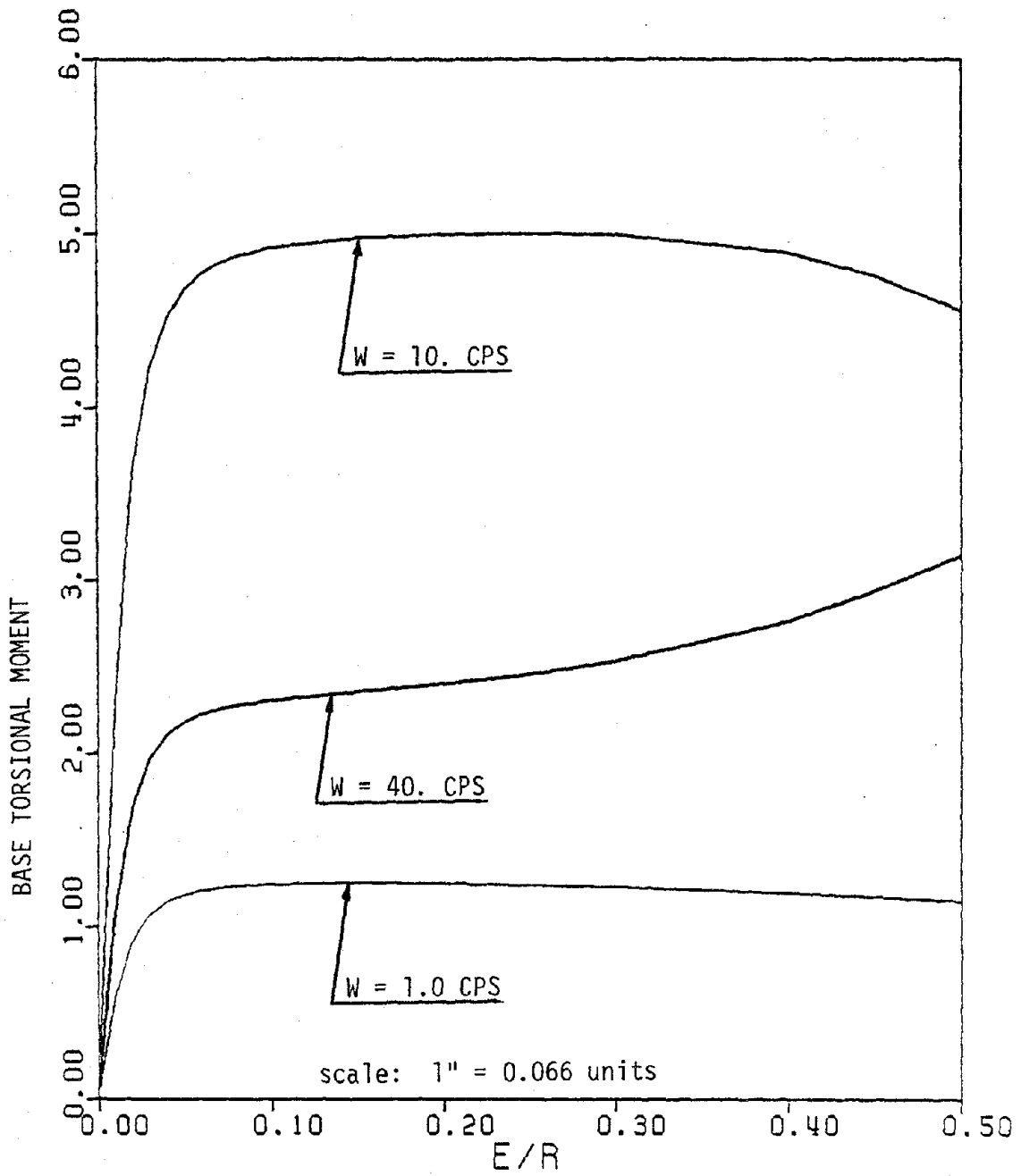

FIG. 4. 26 RMS VALUES OF NORMALIZED BASE TORSIONAL MOMENT FOR FREQUENCY PARAMETER VALUES OF 1, 10 AND 40 CPS.

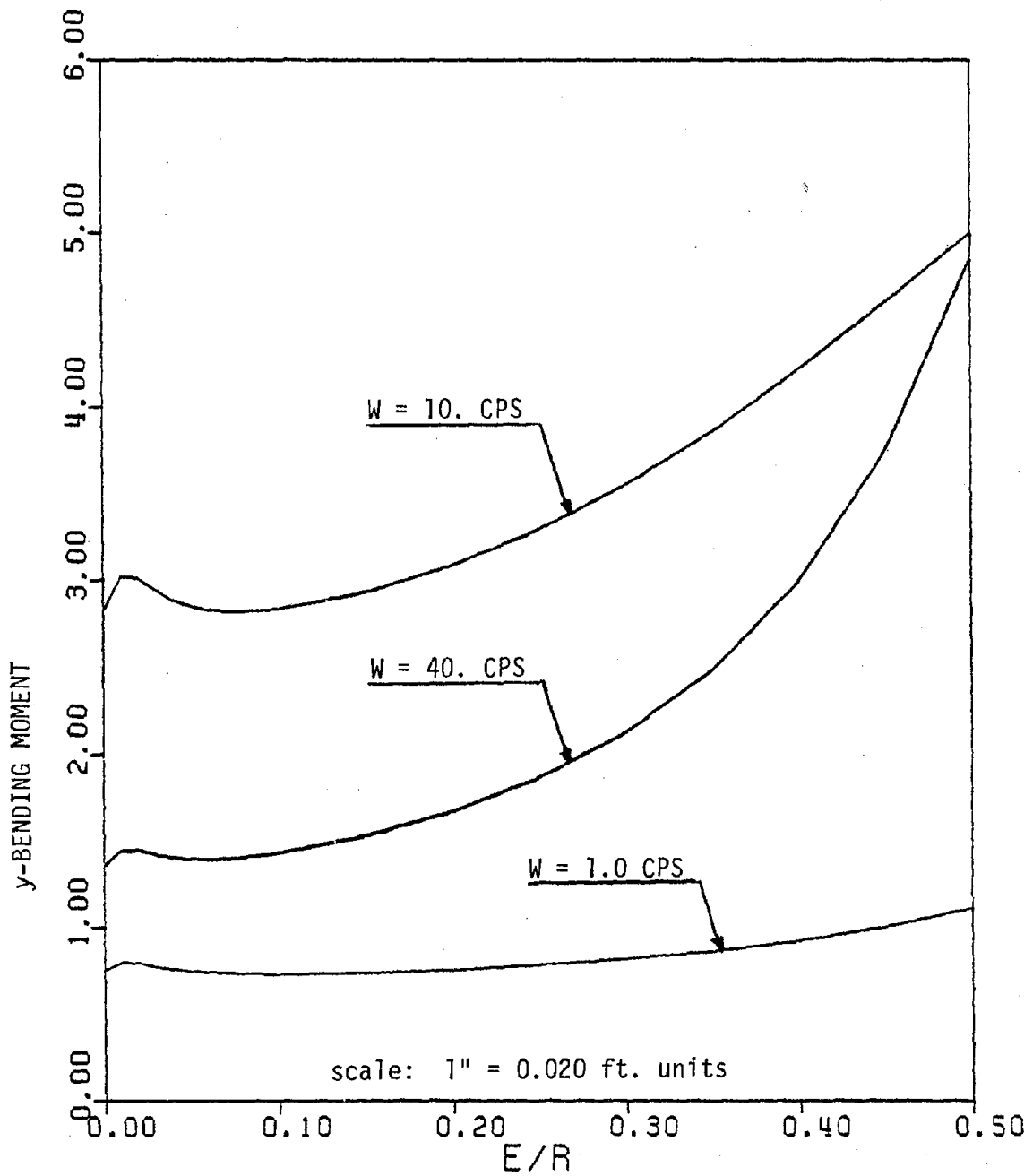

FIG. 4.27 RMS VALUES OF NORMALIZED BASE y-BENDING MOMENT IN COLUMN 1 FOR FREQUENCY PARAMETER VALUES OF 1, 10 AND 40 CPS.

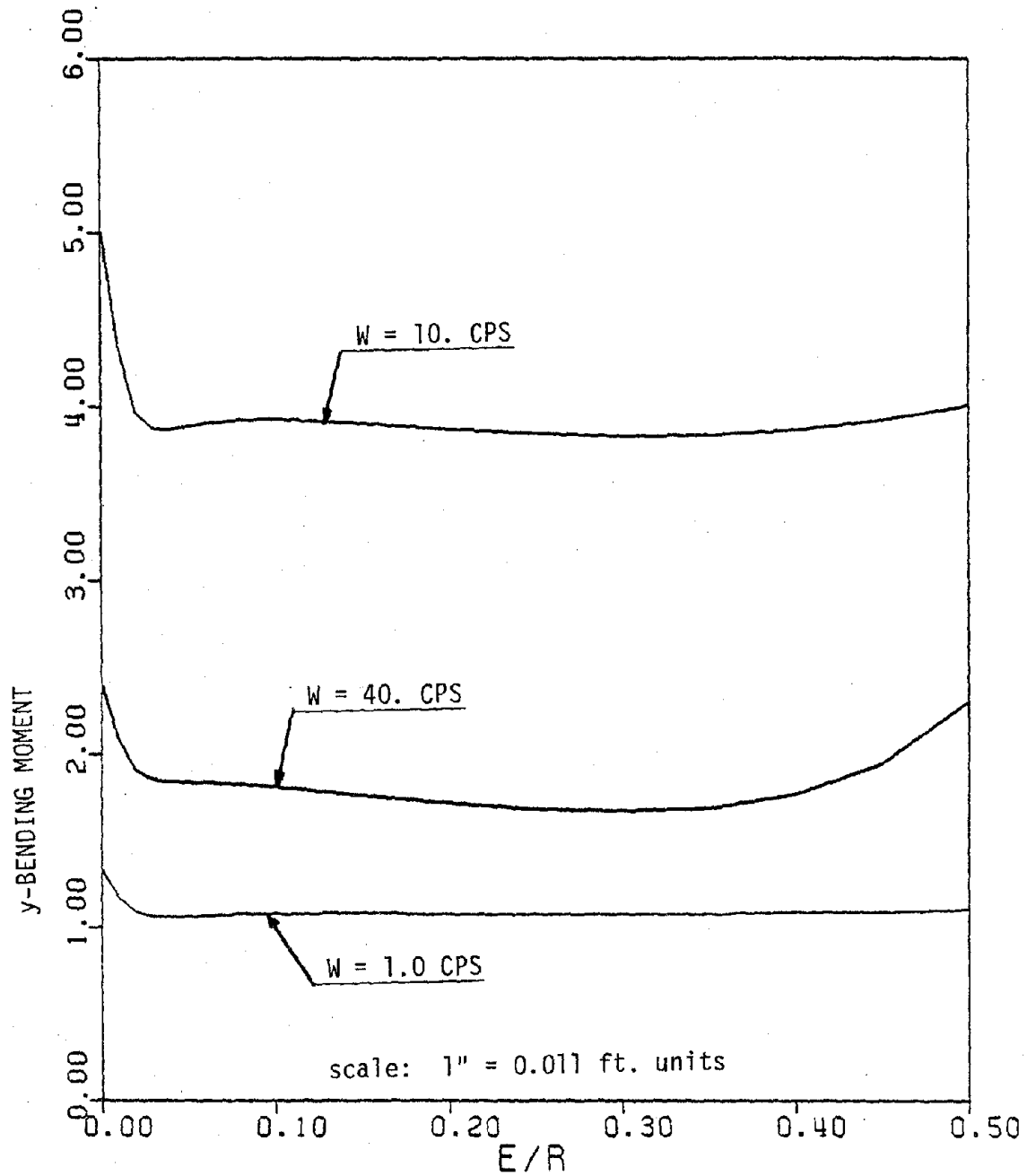

FIG. 428 RMS VALUES OF NORMALIZED BASE y-BENDING MOMENT IN COLUMN 5 FOR FREQUENCY PARAMETER VALUES OF 1, 10 AND 40 CPS.

$$\begin{bmatrix}
\mu_1 + \mu_2 & \epsilon_1 \mu_1 + \epsilon_2 \mu_2 & -\mu_2 & -\epsilon_2 \mu_2 & 0 & 0 \\
\epsilon_1 \mu_1 + \epsilon_2 \mu_2 & \mu_1 \psi_1 + \mu_2 \psi_2 & -\epsilon_2 \mu_2 & -\mu_2 \psi_2 & 0 & 0 \\
-\mu_2 & -\epsilon_2 \mu_2 & \mu_2 + \mu_3 & \epsilon_2 \mu_2 + \epsilon_3 \mu_3 & -\mu_3 & -\epsilon_3 \mu_3 \\
-\epsilon_2 \mu_2 & -\mu_2 \psi_2 & \epsilon_2 \mu_2 + \epsilon_3 \mu_3 & \mu_2 \psi_2 + \mu_3 \psi_3 & -\epsilon_3 \mu_3 & -\mu_3 \psi_3 \\
\vdots & \vdots & \vdots & \vdots & \vdots & \vdots \\
-\mu_1 & -\epsilon_1 \mu_1 & \mu_1 + \mu_{i+1} & \epsilon_1 \mu_1 + \epsilon_{i+1} \mu_{i+1} & -\mu_{i+1} & -\epsilon_{i+1} \mu_{i+1} \\
-\epsilon_1 \mu_1 & -\mu_1 \psi_1 & \epsilon_1 \mu_1 + \epsilon_{i+1} \mu_{i+1} & \mu_1 \psi_1 + \mu_{i+1} \psi_{i+1} & -\epsilon_{i+1} \mu_{i+1} & -\mu_{i+1} \psi_{i+1} \\
\vdots & \vdots & \vdots & \vdots & \vdots & \vdots \\
-\mu_{N-1} & -\epsilon_{N-1} \mu_{N-1} & \mu_{N-1} + \mu_N & \epsilon_{N-1} \mu_{N-1} + \epsilon_N \mu_N & -\mu_N & -\epsilon_N \mu_N \\
-\epsilon_{N-1} \mu_{N-1} & -\mu_{N-1} \psi_{N-1} & \epsilon_{N-1} \mu_{N-1} + \epsilon_N \mu_N & \mu_{N-1} \psi_{N-1} + \mu_N \psi_N & -\epsilon_N \mu_N & -\mu_N \psi_N \\
0 & 0 & 0 & 0 & \mu_N & \epsilon_N \mu_N \\
0 & 0 & 0 & 0 & -\epsilon_N \mu_N & -\mu_N \psi_N
\end{bmatrix}$$

(I.3)

$[C] = 2B\omega$
(m,m)

$$\begin{bmatrix}
 \eta_1 + \eta_2 & \varepsilon_1 \eta_1 + \varepsilon_2 \eta_2 & -\eta_2 & -\varepsilon_2 \eta_2 & 0 & 0 \\
 \varepsilon_1 \eta_1 + \varepsilon_2 \eta_2 & \kappa_1 \eta_1 + \kappa_2 \eta_2 & -\varepsilon_2 \eta_2 & -\kappa_2 \eta_2 & 0 & 0 \\
 -\eta_2 & -\varepsilon_2 \eta_2 & \eta_2 + \eta_3 & \varepsilon_2 \eta_2 + \varepsilon_3 \eta_3 & -\eta_3 & -\varepsilon_3 \eta_3 \\
 -\varepsilon_2 \eta_2 & -\kappa_2 \eta_2 & \varepsilon_2 \eta_2 + \varepsilon_3 \eta_3 & \kappa_2 \eta_2 + \kappa_3 \eta_3 & -\varepsilon_3 \eta_3 & -\kappa_3 \eta_3 \\
 \dots & \dots & \dots & \dots & \dots & \dots \\
 -\eta_i & -\varepsilon_i \eta_i & \eta_i + \eta_{i+1} & \varepsilon_i \eta_i + \varepsilon_{i+1} \eta_{i+1} & -\eta_{i+1} & -\varepsilon_{i+1} \eta_{i+1} \\
 -\varepsilon_i \eta_i & -\kappa_i \eta_i & \varepsilon_i \eta_i + \varepsilon_{i+1} \eta_{i+1} & \kappa_i \eta_i + \kappa_{i+1} \eta_{i+1} & -\varepsilon_{i+1} \eta_{i+1} & -\kappa_{i+1} \eta_{i+1} \\
 \dots & \dots & \dots & \dots & \dots & \dots \\
 0 & -\varepsilon_{N-1} \eta_{N-1} & -\eta_{N-1} & -\varepsilon_{N-1} \eta_{N-1} & \eta_{N-1} + \eta_N & \varepsilon_{N-1} \eta_{N-1} + \varepsilon_N \eta_N & -\eta_N & -\varepsilon_N \eta_N \\
 0 & 0 & -\varepsilon_{N-1} \eta_{N-1} & -\kappa_{N-1} \eta_{N-1} & \varepsilon_{N-1} \eta_{N-1} + \varepsilon_N \eta_N & \kappa_{N-1} \eta_{N-1} + \kappa_N \eta_N & -\varepsilon_N \eta_N & -\kappa_N \eta_N \\
 0 & 0 & 0 & 0 & -\eta_N & -\varepsilon_N \eta_N & \eta_N & -\kappa_N \eta_N \\
 0 & 0 & 0 & 0 & -\varepsilon_N \eta_N & -\kappa_N \eta_N & \varepsilon_N \eta_N & \kappa_N \eta_N
 \end{bmatrix}$$

$$[K] = \omega^2 \begin{matrix} (m, m) \end{matrix}$$

(I.4)

These matrices can also be partitioned as follows:

Mass Matrix

$$[M] = \begin{bmatrix} M^1 & & & & \\ & M^2 & & & \\ & & \ddots & & \\ & & & M^i & \\ & & & & \ddots & \\ & & & & & M^{N-1} \\ 0. & & & & & & M^N \end{bmatrix} \quad (I.5)$$

where

$$M^i = \begin{bmatrix} \rho_i & 0 \\ 0 & \rho_i \left(\frac{r_i}{r}\right)^2 \end{bmatrix} \quad (I.6)$$

Damping Matrix

$$[C] = 2\beta\omega \begin{bmatrix} c^1+c^2 & -c^2 & & & & & \\ & -c^2 & c^2+c^3 & -c^3 & & & \\ & & & \ddots & & & \\ & & & & -c^i & c^i+c^{i+1} & -c^{i+1} \\ & & & & & \ddots & \\ & & & & & & -c^{N-1} & c^{N-1}+c^N & -c^N \\ & & & & & & & -c^N & c^N \end{bmatrix} \quad (I.7)$$

where

$$c^i = \begin{bmatrix} \mu_i & \epsilon_i \mu_i \\ \epsilon_i \mu_i & \psi_i \mu_i \end{bmatrix} \quad (I.8)$$

$$[C] = 2\beta\omega \quad (N, N) \quad \begin{bmatrix}
 \mu_1 + \mu_2 & -\mu_2 & & & & \\
 -\mu_2 & \mu_2 + \mu_3 & -\mu_3 & & & 0. \\
 & \cdot & \cdot & \cdot & & \\
 & & -\mu_i & \mu_i + \mu_{i+1} & -\mu_{i+1} & \\
 & & & & & \\
 0. & & & -\mu_{N-1} & \mu_{N-1} + \mu_N & -\mu_N \\
 & & & & -\mu_N & \mu_N
 \end{bmatrix} \quad (I.12)$$

$$[K] = \omega^2 \quad (N, N) \quad \begin{bmatrix}
 \eta_1 + \eta_2 & -\eta_2 & & & & \\
 -\eta_2 & \eta_2 + \eta_3 & -\eta_3 & & & 0. \\
 & \cdot & \cdot & \cdot & & \\
 & & -\eta_i & \eta_i + \eta_{i+1} & -\eta_{i+1} & \\
 & & & & & \\
 0. & & & -\eta_{N-1} & -\eta_{N-1} + \eta_N & -\eta_N \\
 & & & & -\eta_N & \eta_N
 \end{bmatrix} \quad (I.13)$$

APPENDIX-II

Various terms and their corresponding derivatives used in proportional and nonproportional damping cases in Chapter 3 are defined in this Appendix.

II.1 Proportional Damping Case

II.1.1 Frequency Integrals

Frequency integrals used in Eq. (3.1) are defined as follows:

$$a. \quad I_1(\omega_j) = c^2 \int_{-\infty}^{\infty} \Phi_g(\omega) \frac{\omega_j^4}{(\omega_j^2 - \omega^2)^2 + 4\beta_j^2 \omega_j^2 \omega^2} d\omega \quad (II.1)$$

This integrals for the spectral density defined by Eq. (4.1) can be written as:

$$I_1(\omega_j) = \sum_{i=1}^3 \frac{\pi}{2} S_i \omega_i \omega_j \frac{G_1(\omega_j, \beta_j)}{B(\omega_j, \beta_j)} \quad (II.2)$$

where

$$G_1(\omega_j, \beta_j) = (\beta_i \omega_i + \beta_j \omega_j) [\omega_i^2 + \omega_j^2 + 4\beta_i \beta_j \omega_i \omega_j + 4\beta_i^2 \omega_j^2] - \omega_i \omega_j (\beta_i \omega_j + \beta_j \omega_i) \quad (II.3)$$

$$B(\omega_j, \beta_j) = \omega_i \omega_j [(\beta_i \omega_j + \beta_j \omega_i)^2 + (\beta_i \omega_i + \beta_j \omega_j)^2] - (\beta_i \omega_i + \beta_j \omega_j) (\beta_i \omega_j + \beta_j \omega_i) (\omega_i^2 + \omega_j^2 + 4\beta_i \beta_j \omega_i \omega_j) \quad (II.4)$$

in which S_i , ω_i and β_i are parameters of the spectral density function as shown in Table 4.1.

$$b. \quad I_2(\omega_j) = c^2 \int_{-\infty}^{\infty} \Phi_g(\omega) \frac{\omega_j^2 \omega^2}{(\omega_j^2 - \omega^2)^2 + 4\beta_j^2 \omega_j^2 \omega^2} d\omega \quad (II.5)$$

which can be written as:

$$I_2(\omega_j) = \sum_{i=1}^3 \frac{\pi}{2} S_i \omega_i \omega_j \frac{G_2(\omega_j, \beta_j)}{B(\omega_j, \beta_j)} \quad (\text{II.6})$$

where

$$G_2(\omega_j, \beta_j) = 4\beta_i^2 \omega_i \omega_j (\beta_i \omega_j + \beta_j \omega_i) + \omega_i^2 (\beta_i \omega_i + \beta_j \omega_j) \quad (\text{II.7})$$

The rates of change of these frequency integrals can be obtained using the following derivatives:

$$\frac{\partial}{\partial x} \left[\frac{I_\ell(\omega_j)}{\omega_j} \right] = \frac{1}{\omega_j} \left[\omega_j \frac{\partial I_\ell(\omega_j)}{\partial x} - 4I_\ell(\omega_j) \frac{\partial \omega_j}{\partial x} \right] \quad (\text{II.8a})$$

and

$$\frac{\partial}{\partial x} \left[\frac{I_\ell(\omega_j)}{\omega_j^2} \right] = \frac{1}{\omega_j^2} \left[\omega_j \frac{\partial I_\ell(\omega_j)}{\partial x} - 2I_\ell(\omega_j) \frac{\partial \omega_j}{\partial x} \right] \quad (\text{II.8b})$$

$$\begin{aligned} \frac{\partial I_\ell(\omega_j)}{\partial x} = & \sum_{i=1}^3 \frac{\pi}{2} S_i \omega_i \left\{ \left[\frac{\partial \omega_j}{\partial x} G_\ell(\omega_j, \beta_j) + \omega_j \frac{\partial G_\ell(\omega_j, \beta_j)}{\partial x} \right] \right. \\ & \left. - \omega_j G_\ell(\omega_j, \beta_j) \frac{\partial B(\omega_j, \beta_j)}{\partial x} \right\} / [B(\omega_j, \beta_j)]^2 \end{aligned} \quad (\text{II.9})$$

where,

$$\frac{\partial G_\ell(\omega_j, \beta_j)}{\partial x} = \frac{\partial G_\ell}{\partial \omega_j} \frac{\partial \omega_j}{\partial x} + \frac{\partial G_\ell}{\partial \beta_j} \frac{\partial \beta_j}{\partial x} \quad (\text{II.10})$$

where $\ell = 1$ and 2 in Eqs. (II.8)-(II.10) pertain to I_1 and I_2 respectively, and

$$\frac{\partial G_1}{\partial \omega_j} = \beta_j [\omega_j^2 + 8\beta_i \beta_j \omega_i \omega_j + 4\beta_i^2 (\omega_i^2 + 3\omega_j^2)] + 8\beta_i^3 \omega_i \omega_j \quad (\text{II.11a})$$

$$\frac{\partial G_1}{\partial \beta_j} = \omega_j [\omega_j^2 + 8\beta_i \beta_j \omega_i \omega_j + 4\beta_i^2 (\omega_i^2 + \omega_j^2)] \quad (\text{II.11b})$$

$$\frac{\partial G_2}{\partial \omega_j} = 4\beta_i^2 \omega_i (2\beta_i \omega_j + \beta_j \omega_i) + \omega_i^2 \beta_j \quad (\text{II.11c})$$

$$\frac{\partial G_2}{\partial \beta_j} = \omega_i^2 \omega_j (4\beta_i^2 + 1.) \quad (\text{II.11d})$$

$$\frac{\partial B(\omega_j, \beta_j)}{\partial x} = \frac{\partial B}{\partial \omega_j} \frac{\partial \omega_j}{\partial x} + \frac{\partial B}{\partial \beta_j} \frac{\partial \beta_j}{\partial x} \quad (\text{II.12})$$

in which

$$\begin{aligned} \frac{\partial B}{\partial \omega_j} = & \omega_i [(\beta_i \omega_j + \beta_j \omega_i)^2 + (\beta_i \omega_i + \beta_j \omega_j)^2] \\ & + 2\omega_i \omega_j [\beta_i (\beta_i \omega_j + \beta_j \omega_i) + \beta_j (\beta_i \omega_i + \beta_j \omega_j)] \\ & - [\beta_j (\beta_i \omega_j + \beta_j \omega_i) + \beta_i (\beta_i \omega_i + \beta_j \omega_j)] (\omega_i^2 + \omega_j^2 + 4\beta_i \beta_j \omega_i \omega_j) \\ & - 2(\beta_i \omega_j + \beta_j \omega_i)(\beta_i \omega_i + \beta_j \omega_j)(\omega_j + 2\beta_i \beta_j \omega_i) \end{aligned} \quad (\text{II.13a})$$

$$\begin{aligned} \frac{\partial B}{\partial \beta_j} = & 2\omega_i \omega_j [\omega_i (\beta_i \omega_j + \beta_j \omega_i) + \omega_j (\beta_i \omega_i + \beta_j \omega_j)] \\ & - [\omega_j (\beta_i \omega_j + \beta_j \omega_i) + \omega_i (\beta_i \omega_i + \beta_j \omega_j)] (\omega_i^2 + \omega_j^2 + 4\beta_i \beta_j \omega_i \omega_j) \\ & - 4(\beta_i \omega_i + \beta_j \omega_j)(\beta_i \omega_j + \beta_j \omega_i) \beta_i \omega_i \omega_j \end{aligned} \quad (\text{II.13b})$$

II.1.2 Partial Fraction Factors P,Q,R,S

Constants P,Q,R and S are obtained from the solution of the following simultaneous equations [30]:

$$[c]\{T\} = \{W\} \quad (\text{II.14})$$

where

$$[c] = \begin{bmatrix} 1 & 0 & 1 & 0 \\ u & 1 & s & 1 \\ v & u & t & s \\ 0 & v & 0 & t \end{bmatrix}; \quad \{T\} = \begin{Bmatrix} P \\ Q \\ R \\ S \end{Bmatrix}; \quad \{W\} = \begin{Bmatrix} W_1 \\ W_2 \\ W_3 \\ W_4 \end{Bmatrix} \quad (\text{II.15})$$

in which $u = -2(1-2\beta_k^2)$; $v = 1.0$; $s = -2r^2(1-2\beta_j^2)$; $t = r^4$; $w_1 = 0.$; $w_2 = 1.0$; $w_3 = -(1+r^2-2\beta_j\beta_k r)$; and $w_4 = r^2$.

The rates of change of partial fraction factors $\frac{\partial P}{\partial X}$, $\frac{\partial Q}{\partial X}$, $\frac{\partial R}{\partial X}$ and $\frac{\partial S}{\partial X}$ with respect to a structural parameter can be obtained by solving the following equations:

$$[c] \left\{ \frac{\partial T}{\partial X} \right\} = \left\{ \frac{\partial W}{\partial X} \right\} - \left[\frac{\partial C}{\partial X} \right] \{T\} \quad (II.16)$$

in which $\left\{ \frac{\partial W}{\partial X} \right\}$ and $\left[\frac{\partial C}{\partial X} \right]$ are obtained by straight forward differentiation of terms in $[c]$ and $[W]$ with respect to parameter x of interest.

II.2 Nonproportional Damping Case

II.2.1 Frequency Integrals

Frequency integrals used in equation (3.16) are identical to proportional damping case in Section II.1.1.

II.2.2 Partial Fraction Factors P', Q', R', S'

Factors P', Q', R', S' can be obtained from Eq. (II.15) in which matrix $[C]$ remains the same as in Eq. (II.15) and the elements of vector $\{W\}$ are defined as:

$$\begin{aligned} W_1' &= D_1 ; & W_2' &= C_1 D_1 + D_2 + E_2 ; & W_3' &= C_1 D_2 + C_2 D_1 + E_2 ; \\ W_4' &= C_2 D_2 \end{aligned} \quad (II.17)$$

in which

$$\begin{aligned} D_1 &= 4a_j a_k \\ D_2 &= 4r[a_j a_k \beta_j \beta_k + b_j b_k \sqrt{1-\beta_j^2} \sqrt{1-\beta_k^2} - a_j b_k \beta_j \sqrt{1-\beta_k^2} - a_k b_j \beta_k \sqrt{1-\beta_j^2}] \\ C_1 &= -(1 + r^2 - 4\beta_j \beta_k r) ; & C_2 &= r^2 \\ E_2 &= (r\beta_j - \beta_k) ; & E_3 &= r(r\beta_k - \beta_j)F \end{aligned} \quad (II.18)$$

$$F = -8[a_j a_k (\beta_k - r\beta_j) - (a_j b_k \sqrt{1-\beta_k^2} - b_j a_k r \sqrt{1-\beta_j^2})]$$

The derivatives of D_1 , D_2 , C_1 , C_2 , E_2 , E_3 and F and consequently of W_1' , W_2' , W_3' and W_4' are straightforward. Also, factor A_j is defined as:

$$A_j = b_j^2 + (a_j^2 - b_j^2) \beta_j^2 - 2 a_j b_j \beta_j \sqrt{1-\beta_j^2} \quad (\text{II.19})$$

and its derivatives are straightforward.

